





## Table of Contents

<b>Introduction</b> .....	<b>4</b>	<b>RoundRail Linear Guides</b> .....	<b>228</b>
<b>Linear Ball Bushing® Bearings</b> .....	<b>15</b>	End Support 1BA.....	231
<b>Inch Bearings</b> .....	<b>15</b>	End Support 1NA .....	233
Lube for Life.....	20	Continuous Support 1CA .....	235
Super Smart Ball Bushing Bearings .....	21	Continuous Support 1PA.....	238
Super Smart Ball Bushing Pillow Blocks .....	28	FluoroNyliner 1VA.....	240
Super Ball Bushing Bearings .....	44	Side Mounted 1DA. ....	243
Super Ball Bushing Pillow Blocks .....	53	Dual Shaft Rail 2DA .....	246
Precision Steel Ball Bushing Bearings.....	69	Twin Shaft Web 2CA.....	249
Precision Steel Ball Bushing Pillow Blocks.....	78	Accessories.....	252
XR Extra Rigid Ball Bushing Bearings.....	90	<b>Engineering</b> .....	<b>256</b>
XR Extra Rigid Ball Bushing Pillow Blocks.....	94	Performance Criteria .....	257
<b>Specialty Bearings</b> .....	<b>97</b>	Ball Bushing Life Expectancy and Load Capacity....	261
RoundWay® Linear Roller Bearings.....	97	60 Case LinearRace Shafting Specifications .....	263
FluoroNyliner® Bushing Bearings .....	105	Load Consideration .....	264
Food Grade FluoroNyliner Bushing Bearings.....	116	Coefficient of Friction.....	265
Polymer Bushing Bearings .....	119	System Maintenance and Service .....	266
Accessories .....	125	Bearing Options .....	267
<b>Metric Ball Bushing Bearings</b> .....	<b>131</b>	Material Engineering Specifications.....	268
General Product Overview .....	131	60 Case LinearRace Deflection .....	269
Super Smart Ball Bushing Bearings .....	133	How to Cut 60 Case LinearRace Shafting .....	270
Super Smart Ball Bushing Pillow Blocks .....	142	Application Tips .....	271
MultiTrac® Ball Bushing Bearings .....	154	Installation Guidelines .....	272
Super Ball Bushing Bearings .....	162	Tolerance Charts.....	273
Super Pillow Blocks.....	166	Engineering Conversion Factors.....	274
Accessories .....	173	Shafting Color Code Chart.....	275
<b>60 Case® LinearRace® Shafting</b> .....	<b>176</b>		
60 Case Product Overview.....	177		
<b>Inch 60 Case Shafting</b> .....	<b>182</b>		
Support Rails and Support Rail Assemblies .....	189		
Support Block .....	193		
<b>Metric 60 Case Shafting</b> .....	<b>195</b>		
Support Rails and Support Rail Assemblies .....	198		
Support Block .....	201		
<b>Quick Shaft</b> .....	<b>202</b>		
<b>Special Machining</b> .....	<b>206</b>		



## Ball Bushing® Bearings

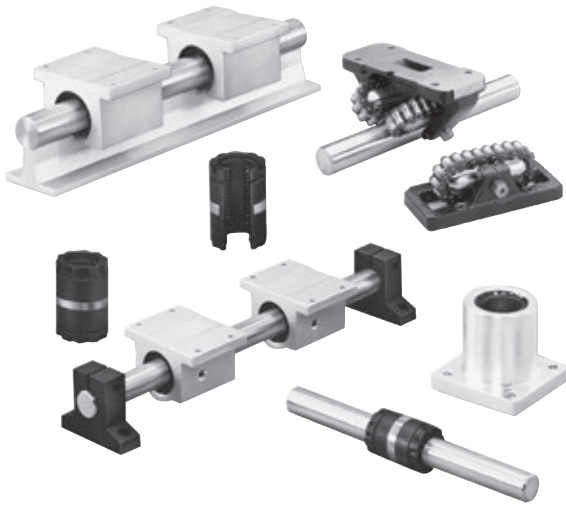

Thomson offers an extensive family of linear bearings. Super Smart Ball Bushing Bearings are available in inch and metric sizes. Thomson uses the latest technology - universally self-aligning bearings. These bearings are offered in a dual-track design and offer load capacities up to 7,760 lb<sub>f</sub> (30,000N). The Super Smart Ball Bushing Bearings are available in sizes 0.5 to 1.5" (8 to 40mm). Super Ball Bushing pillow blocks are available in closed, adjustable and open styles in both single and twin versions. These are the original, self-aligning, precision, anti-friction linear bearing with load capacities up to 4,000 lb<sub>f</sub> and speed up to 10 ft./sec (3 m/s). Thomson offers the largest selection of sizes. A Bearings are the original, precision, anti-friction linear bearing with all-steel construction, load capacities up to 5,000 lb<sub>f</sub> and high operating temperature capabilities. Thomson Die Set Ball Bushing Bearings offer high operating temperature

capabilities, all-steel construction and load capacities up to 1100 lb<sub>f</sub>. RoundWay® bearings are capable of load capacities up to 24,000 lb<sub>f</sub> with travel speeds up to 100 ft./sec. These bearings offer high performance in highly contaminated environments.

Metric Super Ball Bushing Bearings offer high performance from superior design. A coefficient of friction as low as 0.001. This allows the use of smaller, less expensive motors, belts, gears and ball screws, when replacing high-friction, plain bearings. A self-aligning capability up to 0.5° compensates for inaccuracies in base flatness or carriage machining. Achieved with Thomson Super Bearing plates, which have defined radius crowns for maximized self-alignment accuracy. Accelerations as high as 150 m/s<sup>2</sup> and steady state travel speeds up to 3 m/s without the derating factors commonly required with linear guides. Quick-to-ship, drop-in replacement parts for existing applications.

Stainless Steel MultiTrac and A Ball Bushing Bearings are ideal for harsh environments. Stainless steel (440) components resist rust and corrosion. A Bearings withstand up to 600°F (315°C). MultiTrac Ball Bushing Bearings are rated at a maximum of 180°F (82°C). MultiTrac has wear-resistant, engineered-polymer retainers to reduce inertia and noise levels. Quick-to-ship, drop-in replacement parts for existing applications.



## FluoroNyliner® and Polymer Bushing Bearings

FluoroNyliner Bushing Bearings are recommended for washdown and contaminated environments. These bearings and pillow blocks offer load capacities up to 14,000 lb<sub>f</sub>. Polymer Bushing Bearings, which handle loads up to 2000 lb<sub>f</sub>, are ideal for machines in which moment load is non-critical or contamination is a concern.

Polymer Bushing Bearings offer linear motion designers a reliable, yet economical, option for machines in which alignment and moment load are non-critical or those that require shafting that is incompatible with traditional ball bushings. Polymer bushings are a corrosion-resistant option for low-load, low-speed applications.

## Shafting

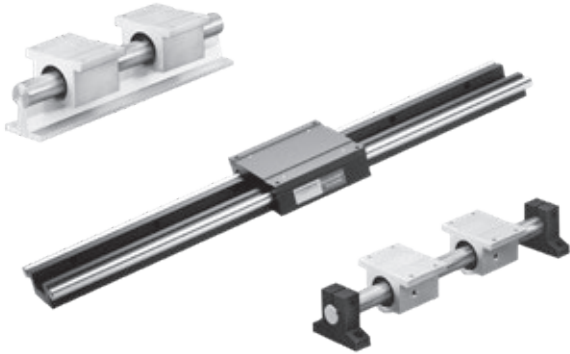

While shafts may appear the same, there are significant performance differences due to the manufacturer's selected standards, and the manufacturing processes used to achieve them. The linear inner race demands the highest levels of material cleanliness, surface topography, surface hardening, diameter, taper and roundness, surface finish and straightness to provide optimum performance, minimal maintenance and long life. Unlike common shafting, Thomson 60 Case® LinearRace® shafting is manufactured to the highest quality standards. Our techniques are continuously upgraded with proprietary know-how gained from more than 75 years of linear bearing design and manufacturing. Using 60 Case LinearRace shafting with Thomson Ball Bushing Bearings ensures optimal bearing performance and travel life.

## RoundRail Linear Guides



Pre-assembled, ready-to-install stages providing low friction, smooth, accurate motion for a wide range of moment or normal loading configurations. Market applications include factory automation, medical, packaging, machine tool, semiconductor, printing, automotive assembly, aerospace and food processing. Slide tables are available as customizable RoundRail linear guides to multi-axis, turnkey systems complete with motors, drives, controls and electromechanical accessories.

- Applications typically on factory machinery where accurate, smooth linear positioning is required
- Available with servo/stepper motor and drive packages
- Max thrust to 3,100 lb.
- Strokes to 120"
- Loads from 5 - 2,000 lb.
- Repeatability to 0.0002"

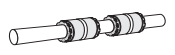
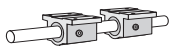
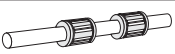
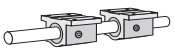
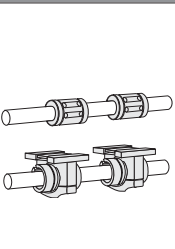
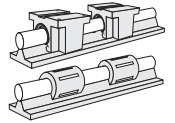
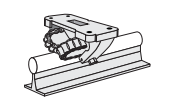
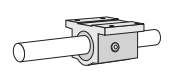

## Ball Bushing® Bearings

	Page Number	Imperial (Inch)								
		1/8	3/16	1/4	3/8	1/2	5/8	3/4	1	
<b>Super Smart</b>										
	<b>Ball Bushing Bearings</b> corrosion-resistant option available	inch: 21 metric: 133					○	○	○	○
	<b>Ball Bushing Pillow Blocks</b> corrosion-resistant option available	inch: 28 metric: 142					○ STAF	○ STA	○ STAF	○ STAF
<b>Super</b>										
	<b>Ball Bushing Bearings</b> corrosion-resistant option available	inch: 44 metric: 162		●	●	●	○	○	○	○
	<b>Ball Bushing Pillow Blocks</b> corrosion-resistant option available	inch: 53 metric: 166			● STA	● STA	○ STAF	○ STA	○ STAF	○ STAF
<b>Precision Bearings</b>										
	<b>A Bearings and Pillow Blocks</b> available in stainless steel	69			●	● SA	○ SA	○ SA	○ SA	○ SA
	<b>MultiTrac®</b> available in stainless steel	154								
	<b>Instrument</b>	80	●	●	●					
	<b>Die Set</b>	82								●
<b>XR Extra Rigid</b>										
	<b>Ball Bushing Bearings and Pillow Blocks</b>	90								
<b>Specialty</b>										
	<b>Cartridge Bearing</b>	51			● ST	● ST	● ST			
	<b>RoundWay®</b>	97					●			●
<b>FluoroNyliner</b>										
	<b>Bushing Bearings</b>	105			○	○	○	○	○	○
	<b>Pillow Blocks</b>	110			○ ST	○ ST	○ STF	○ ST	○ STF	○ STF

- Closed Type
- Open Type
- ◎ Closed and Open Type
- S Single Configuration
- T Twin Configuration
- A Adjustable Configuration
- F Flanged Configuration

Imperial (Inch)						Metric (mm)										
1 1/4	1 1/2	2	2 1/2	3	4	5	8	10	12	16	20	25	30	35	40	50
○	○						●		○	○	○	○	○		○	
○	○						●		○	○	○	○	○		○	
STAF	STAF						STA		STA	STA	STA	STA	STA		STA	
○	○	○					●		○	○	○	○	○		○	○
○	○	○					●		○	○	○	○	○		○	○
STAF	STAF	STA					STA		STA	STA	STA	STA	STA		STA	STA
○	○	○	○	○	○											
○	○	○	○	○	○											
SA	SA	SA	SA	SA	SA											
							●		○	○	○	○	○	○	○	○
							SA		SA	SA	SA	SA	SA	SA	SA	SA
●	●	●														
		○			○											
		●	●		●	●										
○	○	○														
○	○	○														
STF	STF	ST														



## Standard 60 Case® Shaft Size and Availability Chart

Material	Carbon Steel										440C Stainless Steel			52100 Tubular		316 SS			
	60 min.										50 min.			55 min.	58 min.		20-25		
Tolerance Class	L					S	N		D	XL	G	L	S	G	Instrument	L	S	L	
Optional Features	L	DC	PD CPPE	CPPE	PD	S	DC	N				L	PD						
1/8"																			
3/16"	•																		
1/4"	•					•		•			•	•		•	•	•			
3/8"	•					•		•			•	•		•	•				•
1/2"	•		•	•	•	•		•			•	•	•	•	•				•
5/8"	•		•	•	•	•		•			•	•	•	•	•				•
3/4"	•	•	•	•	•	•	•	•			•	•	•	•	•		•	•	•
7/8"	•	•						•	•										
1"	•	•	•	•	•	•	•	•	•		•	•	•	•	•		•	•	•
1 1/8"	•	•						•	•										
1 1/4"	•	•	•	•	•	•	•	•	•			•	•	•					•
1 3/8"	•																		
1 1/2"	•	•	•	•	•	•	•	•	•			•	•	•			•	•	•
1 5/8"	•																		
1 3/4"	•	•						•	•										
2"	•	•	•	•	•	•	•	•	•	•		•	•	•			•	•	
2 1/4"	•	•						•	•										
2 1/2"	•	•						•	•	•			•	•			•	•	
3"	•	•						•	•	•							•	•	
3 1/2"	•	•																	
4"	•																		
Catalog Page	183	185	184	184	184	183	185	183	183	183	185	186	186	186	187	187	187	187	188

Material	Carbon Steel		440C SS
	60 min.		50 min.
Tolerance Class	MM (ISO h6)		MM (ISO h6)
Optional Features	MM	Tx Predrilled	
5 mm	•		•
8 mm	•		•
10 mm	•		•
12 mm	•	•	•
15 mm	•		
16 mm	•	•	•
20 mm	•	•	•
25 mm	•	•	•
30 mm	•	•	•
40 mm	•	•	•
50 mm	•		•
60 mm	•		•
80 mm	•		
Catalog Page	195	196	197

Thomson 60 Case shafting is sold as cut-to-length (CTL), random length (RL), special machined (SM) and quick shaft (QS).

Since Thomson grinds and hardens all of its own shafting, diameters and tolerances not listed are available as special grind and are made to order. Minimum lots may apply.

### Tolerance Classes:

- L - For use with XA, Open and Adjustable Ball Bushing® Bearings and Pillow Blocks as well as Super Ball Bushing Bearings and Super Smart Ball Bushing Bearings
- S - For use with A Type Ball Bushings
- N - For use with Needle Roller Bearings
- D - For use with Thomson Die Set Ball Bushing Bearings
- G - Ball Grooved for use with Thomson Super Ball Bushing
- XL - For use with XR Bearing (Carbon Steel)

### Optional Features:

- PD - Predrilled
- CPPE - Chrome-Plated Plain Ends (carbon steel only)
- DC - Deep Case (carbon steel only - random length)
- Tx - Metric Predrilled

### Standard Support Rail Size and Availability Chart

Type	SR	SR-PD	SRA	SRA-SS	SRA-TU	LSR	LSR-PD	LSRA	LSRA-CR	XSR	XSRA
Description	Aluminum Support Rail	Aluminum Support Rail with Predrilled Holes	Aluminum Support Rail Assembly Carbon Steel Shaft	Aluminum Support Rail Assembly 440C SS Shaft	Aluminum Support Rail Assembly 51200 Tubular Shaft	Steel Lower Support Rail	Steel Lower Support Rail with Predrilled Holes	Steel Lower Support Rail Assembly Carbon Steel Shaft	Corrosion Resistant Steel Lower Support Rail Assembly 440C SS Shaft	Extra Rigid Cast Steel Support Rail	Extra Rigid Cast Steel Support Rail Assembly
1/2"	•	•	•	•		•	•				
5/8"	•	•	•	•		•	•	•	•		
3/4"	•	•	•	•	•	•	•	•	•		
1"	•	•	•	•	•	•	•	•	•		
1 1/4"	•	•	•	•		•	•	•	•		
1 1/2"	•	•	•	•	•	•	•	•	•		
2"	•	•	•	•	•	•	•			•	•
2 1/2"						•	•				
3"						•	•			•	•
4"						•	•				
Catalog Page	191	191	192	192	192	191	191	192	192	191	192

### Standard Support Rail Assembly Size and Availability Chart

Type	SRM	SRMTx	SRAMTx	LSRM	LSRMTx	LSRAM	LSRAM-CR
Description	Aluminum Support Rail	Aluminum Support Rail with Predrilled Holes	Aluminum Support Rail Assembly Carbon Steel Shaft	Steel Lower Support Rail	Steel Lower Support Rail with Predrilled Holes	Steel Lower Support Rail Assembly Carbon Steel Shaft	Corrosion Resistant Steel Lower Support Rail Assembly 440C SS Shaft
12mm	•	•	•	•	•		
16mm	•	•	•	•	•	•	•
20mm	•	•	•	•	•	•	•
25mm	•	•	•	•	•	•	•
30mm	•	•	•	•	•	•	•
40mm	•	•	•	•	•	•	•
Catalog Page	200	200	200	200	200	200	200

### Standard Support Block Size and Availability Chart

Type	ASB	FSB	SB	Type	ASBM	SBM
Description	Aluminum Support Block	Flanged Aluminum Support Block	Steel Support Block	Description	Aluminum Support Block	Steel Support Block
1/4"	•		•	8mm	•	•
3/8"	•		•	12mm	•	•
1/2"	•	•	•	16mm	•	•
5/8"			•	20mm	•	•
3/4"	•	•	•	25mm	•	•
1"	•	•	•	30mm	•	•
1 1/4"		•	•	40mm	•	•
1 1/2"	•		•	Catalog Page	201	201
2"						
3"						
4"						
Catalog Page	194	194	194			



RoundRail linear guides are the non-driven building blocks for linear slide tables. They offer the customer flexibility to fit specific envelopes by allowing customized separations between shafts and between bearings on shafts to produce higher moment capacity. When combined with ballscrew assemblies, they become a driven slide table.

Because RoundRail linear guides are offered in a wide range of sizes, bearing types and mounting configurations, they are typically selected by the qualitative attributes that are most appropriate for a given application (i.e. environmental considerations, mounting footprint). For this reason, we are providing the following selection chart and selection criteria for consideration:

## Systems Quick Reference Guide

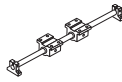
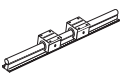
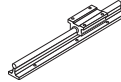
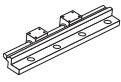
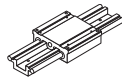
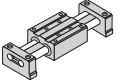
Application Criteria		End Support	Continuous Support	FluoroNyliner	Side Mounted	Dual Shaft Rail	Twin Shaft Web
							
		<b>1BA / 1NA</b>	<b>1CA / 1PA</b>	<b>1VA</b>	<b>1DA</b>	<b>2DA</b>	<b>2CA</b>
<b>High Loads</b>			•	•			
<b>Equivalent Loads in All Directions</b>		•				•	
<b>Ultra Compactness</b>		•					•
<b>Extreme Smoothness</b>		•	•		•		•
<b>End Supported</b>		•				•	•
<b>Single Rail</b>							•
<b>Harsh Environment</b>				•			
<b>Low Cost Installation (multiple rail)</b>		•	•	•	•		
<b>Complete Axis Solution</b>							•
<b>Available Sizes:</b>	<b>Inch</b>	4 thru 24	8 thru 24	8 thru 24	•	•	
	<b>Metric</b>	8 thru 40	12 thru 40		8 thru 16	8 thru 16	8 thru 16
<b>Page Number</b>		231/233	236/238	241	244	247	250

## Linear Guide Selection Criteria

- Load/Life
- Smoothness of Travel
- Cost of Product
- Travel Accuracy
- Speed & Acceleration
- Cost of Installation
- Rigidity
- Envelope
- Cost of Replacement
- Environment

## Application Examples

- Machine Tools
- Semiconductor Equipment
- Packaging Machinery
- Medical Equipment
- Automotive Assembly Equipment
- Food Processing Equipment

# Round or Square?

## Let Thomson help you choose the right rail type and carriage

Since the introduction of the square, or profile rail, linear guide in the 1970s, the design engineer has been faced with the pivotal question: **round or square?**

While square rail initially costs many times more than round technology due to the extensive grinding requirements inherent in the design, new manufacturing techniques and economies of scale have allowed square rail to compete effectively in a broader application space. Once subjugated to the realm of machine tools, profile rail can now be found in many of the same applications that were once only supported by round rail. However, Ball Bushing® guides remain popular due to some intrinsically unique and often advantageous characteristics that lend themselves to specific applications.

In order to apply the correct type of linear guide in a particular application, the design engineer must consider the advantages and capabilities of each. The cost of selecting the wrong technology can result in a lot of additional design complexity, poor function and cost in the overall assembly. As a first cut, it is useful to have a general understanding of the strengths and weaknesses of each type of product.

The table below outlines typical performance characteristics of round and profile rail and where one is superior.





Attribute	Round	Square
<b>Performance</b>		
Load Capacity	medium	<b>high</b>
Accuracy	medium	<b>medium - high</b>
Stiffness	medium	<b>high</b>
Available preload	yes (light)	<b>yes (light - heavy)</b>
Single guide supports moments	no	<b>yes</b>
Same load capacity in all directions	no	<b>available (typical)</b>
Seal effectiveness	<b>high</b>	medium
Smoothness	<b>high</b>	medium - high
Drag	<b>low</b>	medium - high
<b>Total Cost of Ownership</b>		
Ease of installation	<b>high</b>	medium
Required precision of mating component	<b>low</b>	high
Self aligning	<b>yes</b>	no
Life Expectancy	medium	<b>high</b>
Material Cost	<b>low</b>	medium
<b>Design Flexibility</b>		
Ability to span gaps	<b>yes</b>	no
Can be used as structural frame member	<b>yes</b>	no
Ability to use as single rail & guide	no	<b>yes<sup>1</sup></b>
Compactness (load capacity to size)	medium	<b>high</b>
Ease of modification/Interchangeability	<b>high</b>	low
<b>Rail Mounting</b>		
Available end support mounting	<b>yes (preferred)</b>	no
Available continuous support mounting	yes	<b>yes (preferred)</b>
Available mounting from top of rail	yes	<b>yes (preferred)</b>
Available mounting from bottom of rail	<b>yes</b>	<b>yes</b>

This catalog includes detailed ordering information for RoundRail linear guides. Refer to the separate Thomson profile rail catalog for detailed square rail linear guides information.

1. Depending on the application. Most square rail applications use dual rails.

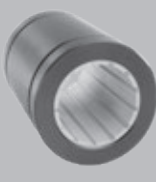



## RoundRail Ball Bushing® Bearings

	Description	Product Overview	Comments
<b>Plain Contact - FluroNyliner</b> 	Provides self-lubricating, low friction, smooth motion for high load conditions.	<ul style="list-style-type: none"> <li>• PTFE tape is bonded to the ID of an aluminum housing.</li> <li>• Suitable for wash-down &amp; food applications.</li> <li>• Can withstand high vibration &amp; shock loads.</li> <li>• Extremely smooth running; does not require an overly smooth surface to run on.</li> <li>• Compensated</li> <li>• Sizes ¼" – 2", closed, open, adjustable</li> </ul>	
<b>Plain Contact - Polymer</b> 	Offer reliable and economical, linear motion for machines in which moment load is non-critical or where contamination is a concern.	<ul style="list-style-type: none"> <li>• Available in sizes of 6 to 50 mm (closed) and 10 to 50 mm (open)</li> <li>• Maintenance-free operation</li> <li>• Polymer liners reduce noise</li> <li>• Dirt and dust resistant</li> <li>• Anodized aluminum adapter</li> <li>• Operate in temperatures ranging from -50°C to 90°C (-58°F to 194°F)</li> </ul>	
<b>Steel Sleeve (A)</b> 	The steel sleeve anti-friction recirculating ball bushing provides rigid low drag movement – ~100x lower drag coefficient than a plain contact bearing.	<ul style="list-style-type: none"> <li>• A Bearings – all steel (operates up to 450°F/232°C) with 3 grades of precision available (A, XA, B); sizes ¼" – 4", closed, open, adjustable.</li> <li>• MAM (MultiTrac® A Metric) – twin track configuration, sleeve and a Delrin retainer; size 8 – 40 mm, closed open, adjustable.</li> <li>• INST BRGS – precision miniature stainless steel (corrosion resistant) - sizes: 1/8" – 1/4".</li> <li>• Die Sets – designed specifically for die movement applications; size: 1" – 2".</li> </ul>	<ul style="list-style-type: none"> <li>• The patented MAM is the smoothest and highest load capacity A-type bearing in the market.</li> <li>• Corrosion-resistant versions available.</li> </ul>
<b>Super</b> 	The self-aligning 52100 bearing plate has a ball conforming groove that, with the Delrin sleeve and retainer provide high load capacity smooth motion.	<ul style="list-style-type: none"> <li>• The ball conforming groove enables the Super bearing to provide 3x the load capacity or 27X the L10 travel life of a conventional steel ball bushing bearing .</li> <li>• Sizes ¼" – 2", 5 – 50mm, open/closed</li> <li>• Ball Groove, Cartridge, Out-Rigger, Segment Bearings, XRs</li> </ul>	<ul style="list-style-type: none"> <li>• Additional seal option on outside of bearing and on the pillow blocks offers sealing preferred over competitors by our customers.</li> <li>• Thomson has the largest installed base in North America.</li> <li>• Competitors have modeled their products after Thomson.</li> </ul>
<b>Super Smart</b> 	<p>Truly self-aligning twin track linear bearing.</p> <p>The 52100 Steel plate pitches, rocks and rolls on a precision hardened steel band to provide universal type alignment capability.</p>	<ul style="list-style-type: none"> <li>• 3 industry standards</li> <li>• Imperial Sizes ½" – 1 1/2"</li> <li>• ISO Metric 16 – 40mm</li> <li>• JIS Metric 16 – 40mm</li> <li>• SS6U, E, J's available 16 – 40mm</li> <li>• Closed and Open</li> </ul>	<ul style="list-style-type: none"> <li>• This patented product provides smooth, quiet, low drag linear movement at 6x the load capacity or 216 x the L10 travel life of a conventional steel linear ball bushing bearing.</li> <li>• Also available in a low cost 6 track version.</li> <li>• Its unique design with the steel band enables the bearing to preserve its ID fit-up and self-aligning capability over extended use.</li> </ul>

	Description	Product Overview	Comments
 <p><b>Specialty Bearings</b></p>	There are a multitude of specialty bearings that can be configured or developed to suit almost any customers' needs.	<ul style="list-style-type: none"> <li>RoundWay® - all-steel construction and a chain that connects the rolling elements; Sizes ½" – 4".</li> <li>NB (nylon ball) Bearings, Cartridge Bearings, etc.</li> </ul>	<ul style="list-style-type: none"> <li>Highest load rating of the linear bearings. The ratings are based on a longer travel than other linear bearings use.</li> <li>The chain enables the bearing to withstand high speeds and accelerations.</li> <li>Temperatures up to 450°F/232°C.</li> <li>Suitable for extremely harsh environments.</li> </ul>

 <p><b>Accessories/Options</b></p>	The host of accessories and options associated with RoundRail bearings are multitudinous.	<ul style="list-style-type: none"> <li>Steel Pillow Blocks, Aluminum Pillow Blocks, Singles, Twins, Closed, Opens, Adjustable, Flanged Pillow Blocks, Self-Aligning PBs, XPBs, XPBOs, CRs, wipers, seals, DDs, stainless steel options, resilient mounts, Lube Fittings, etc.</li> </ul>	<ul style="list-style-type: none"> <li>Largest variety in the industry of customized offerings, accessories, and options that allow for new and broader uses of bearings in unusual, harsh, and state-of-the-art applications.</li> </ul>
---	---	--	---

### 60 Case® LinearRace® Shafting

	Description	Product Overview	Comments
	60 Case Shafting	AISI 1566 • Sizes: 3/16" – 4" and 3 – 80mm  Bolt down from the top Smart Rail	<i>(applies to 60 Case Shafting, 440C &amp; 300 Stainless Steel Shafting, 60 Case Tubular Shafting and their Accessories/Options)</i> <ul style="list-style-type: none"> <li>High grade steel used for standard product – 1566 vs. competitor's 1060.</li> <li>Coil-to-bar mfg. technology permits sourcing of hot rolled material, lower costs, sourcing flexibility, high straightness levels, and controlled sizing prior to induction hardening.</li> <li>Low stress precision grinding techniques to produce: - Dia. tolerance control (&lt;0.0002" - classes D &amp; N) - Roundness variation (&lt;0.000080") - Taper var. on 17' L or ½" dia. tolerance (&lt;0.0002") - Surface finish (&lt; 8 Ra) defect free surface - Straightness (capability to &lt; 0.0005" / foot )</li> <li>Value added machining capabilities of hard turning, radial drill and tapping, milling; journal machining to 0.0002" max. dia. variation and &lt;0.001" concentricity variation.</li> </ul>
	440C & 316 Stainless Steel Shafting	AISI 440C • Sizes: 1/8" – 2 1/2" and 3 - 60mm  AISI 316 • Sizes: 1/4" – 2"	
	60 Case Tubular Shafting	AISI 52100 Tubular • Size: ¾" – 4"	

	Accessories/Options	PD, SM, classes (S, L, D, N, XL, M, MN, G), deep case, SB, ASB, ASBM, FSB, Way Mounts, SR, SRA, LSR, LSRA, SRM, LSRM, XSR's, platings, coatings, metric, etc.	<i>Includes all of above</i>
---	---------------------	---	------------------------------

- Largest product breadth in the industry.
- Most technically advanced product offering that conforms to extremely stringent tolerance specifications.
- 75+ years of manufacturing experience.
- Thomson brand name known for consistent and unparalleled quality.



# Linear Ball Bushing® Bearings

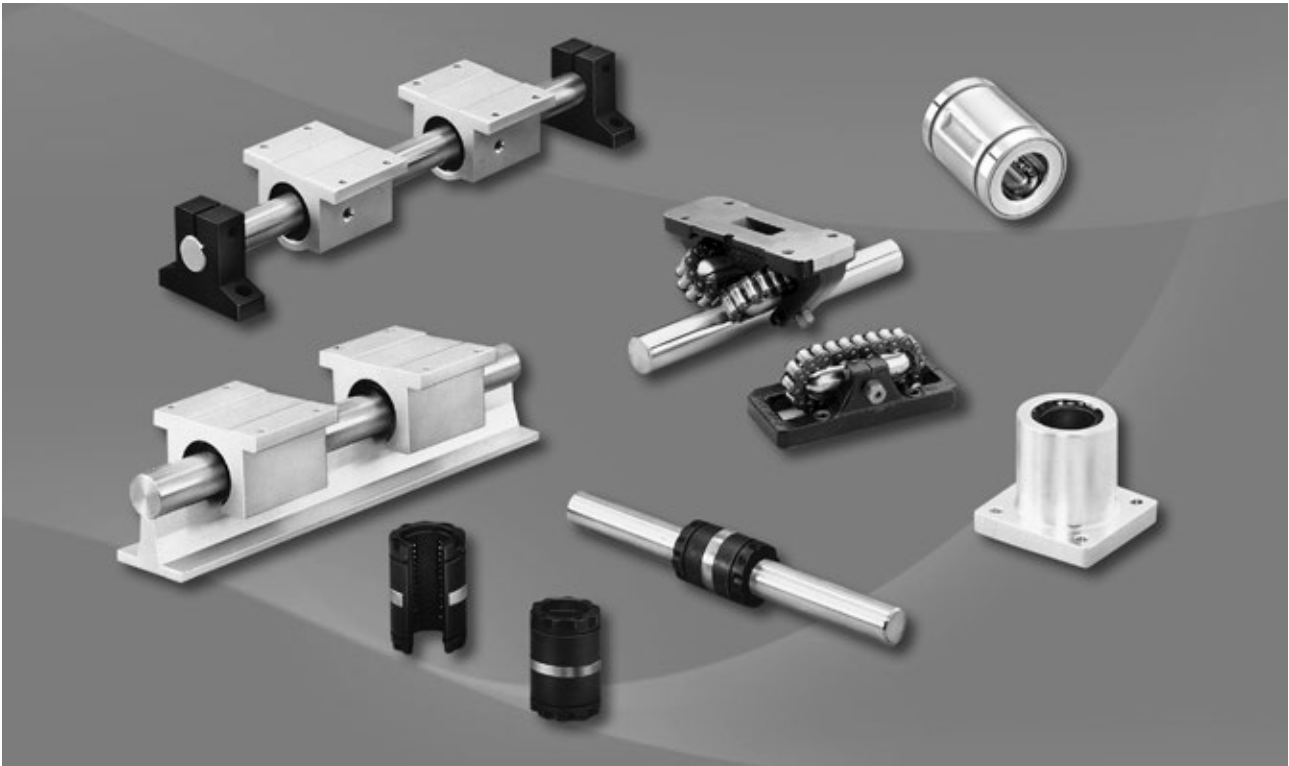

<b>Linear Ball Bushing Bearings.....</b>	<b>15</b>
<b>Inch Bearings.....</b>	<b>15</b>
Lube for Life.....	20
Super Smart Ball Bushing Bearings .....	21
Super Smart Ball Bushing Pillow Blocks .....	28
Super Ball Bushing Bearings .....	44
Super Ball Bushing Pillow Blocks .....	53
Precision Steel Ball Bushing Bearings.....	69
Precision Steel Ball Bushing Pillow Blocks.....	78
XR Extra Rigid Ball Bushing Bearings.....	90
XR Extra Rigid Ball Bushing Pillow Blocks.....	94
<b>Specialty Bearings .....</b>	<b>97</b>
RoundWay® Linear Roller Bearings.....	97
FluoroNyliner® Bushing Bearings .....	105
Food Grade FluoroNyliner.....	116
Polymer Bushing Bearings .....	119
Accessories .....	125
<b>Metric Bearings .....</b>	<b>131</b>
General Product Overview .....	131
Super Smart Ball Bushing Bearings .....	133
Super Smart Ball Bushing Pillow Blocks .....	142
MultiTrac® Ball Bushing Bearings .....	154
Super Ball Bushing Bearings .....	162
Super Pillow Blocks.....	166
Accessories .....	173



# Thomson Linear Motion Components

## The RoundRail Advantage...



### Super Smart Ball Bushing® Bearings

**Thomson Super Smart Ball Bushing Bearings represent a major advancement for linear bearing technology worldwide.**

This patented, self-aligning linear bearing provides twice the load carrying capacity or eight times the travel life of the industry standard Thomson Super Ball Bushing Bearing. This dramatic increase in load capacity allows the use of less expensive drive motors, linkages, gears and ball screws. The unique Super Smart design allows the bearing to maintain its diametrical fit up when installed in housings that are soft or slightly out-of-round. Super Smart Bearings utilize the RoundRail Advantage that eliminates the need for derating factors commonly used with linear guides. The bearings are called "Smart" because their universally self-aligning, double-track design incorporates engineering concepts that literally render old style conventional bearings obsolete. See Page 21.



### Super Smart Ball Bushing Pillow Blocks

**Thomson Super Smart Ball Bushing Pillow Blocks available in closed, adjustable and open styles in both single and twin versions.**

To minimize installation time and cost, the Super Smart Ball Bushing Bearing can be ordered factory installed in an industry standard single or twin pillow block. The closed-type pillow block is used in end-supported applications for spanning or bridging a gap. The open style is used in continuously supported applications when maximum rigidity and stiffness is required. Each Super Smart pillow block is complete with integral double-acting seals that keep out contaminants, retain lubrication and maximize bearing life. Since each pillow block is dimensionally interchangeable with the industry standard Thomson Super Ball Bushing pillow block, system performance improvements can be realized immediately. See Page 28.



### Super Ball Bushing Bearings

**Industry standard, self-aligning Super Ball Bushing Bearings available in 23 sizes and configurations.**

Super Ball Bushing Bearings offer three times the load capacity or 27 times the life of conventional linear bearings. Industry standard, self-aligning Super Ball Bushing Bearings ease installation and minimize wear from minor bore misalignment. Super Ball Bushing Bearings can achieve speeds up to 10 ft./s and accelerations up to 450 ft./s<sup>2</sup> without the derating factors commonly found in linear guide products. With a coefficient of friction as low as .001, Super Ball Bushing Bearings provide a quick, easy replacement for high-friction plain bearings. The wear-resistant, engineered-polymer retainers and outer sleeves reduce inertia and noise in critical, high-speed applications. See Page 44.

**...The RoundRail Advantage** - The inherent ability of a RoundRail Ball Bushing Bearing system to accommodate torsional misalignment (caused by inaccuracies in carriage or base machining or by machine deflection) with little increase in stress to the bearing components.



### Super Ball Bushing Bearing Pillow Blocks

**Available in closed, adjustable and open styles in both single and twin versions.**

Thomson Super Ball Bushing Bearings are also available factory installed in single or twin pillow blocks. Super Ball Bushing Bearing pillow blocks are provided with integral, double-acting seals that keep out contaminants and retain lubrication, maximizing system performance and life. Twin versions provide up to twice the load capacity or eight times the life of single versions, allowing the use of smaller and less expensive drives, motors and ball screws. When replacing v-ways and flat-ways, the Super pillow block's low coefficient of friction reduces power consumption and provides important design economies.

See Page 53.



### Precision Steel Ball Bushing Bearing Products

**Rigid, Precision Steel Ball Bushing Bearing design eliminates binding and chatter found in high friction plain bearings.**

Precision Steel Ball Bushing Bearings are available in an open version for continuously supported applications and a closed version for end-supported applications. Extra precision and adjustable versions are available for end supported applications requiring higher precision and repeatability. Precision Steel Ball Bushing Bearing products are also available factory installed in a self-aligning, malleable iron pillow block, minimizing installation time and cost. The all-steel design makes the Precision Steel Ball Bushing Bearing product line perfect for replacing plain bearings in high-temperature applications. Now available in 440 stainless steel, ideal for harsh and high temperature environments.

See Page 69.



### Miniature Instrument Ball Bushing Bearings

**High Accuracy and Compactness for Instrumentation Level Applications.**

The accuracy level and compact size make the Instrument Ball Bushing Bearing ideal for small mechanisms or devices that require high repeatability and responsiveness. When replacing high-friction, plain bearings, the Instrument Ball Bushing Bearings' constant low coefficient of friction eliminates stick-slip and provides smooth linear performance. Each Instrument Ball Bushing Bearing can be provided with a matched 60 Case® LinearRace® shafting for minimum fit-up, optimizing system performance and accuracy. See Page 80.



## Thomson Linear Motion Components

### The RoundRail Advantage...



#### Die Set Ball Bushing® Bearings

**Available in two accuracy classes and suitable for a variety of industrial applications.**

Thomson Die Set Ball Bushing Bearings are designed to fit the mounting holes of the punch holder in standard dies. When replacing high-friction, plain bearings in standard dies, the result is less machine downtime and increased efficiency. With steady state speeds up to 10 ft./s, the Die Set bearing will provide faster cycle times with improvements in production rates realized immediately. Matched precision ground 60 Case® LinearRace® allows for a close fit-up between the shaft and the LinearRace shafting and bearing, providing critical die alignment. When normal machine service requires bearing replacement, the Die Set bearing can be removed by simply unbolting the toe clamps. See Page 82.

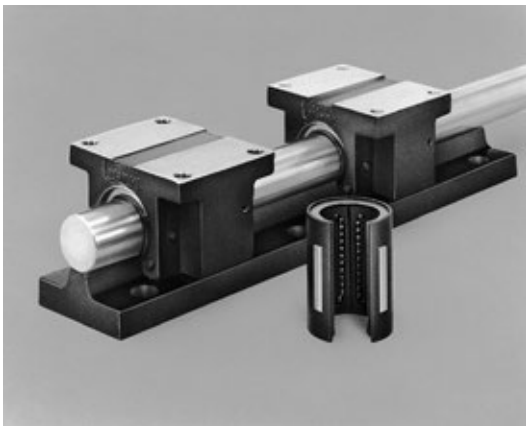

#### XR Ball Bushing Bearing Products

**High load capacity and rigidity combined with the RoundRail Advantage.**

The XR Ball Bushing Bearing provides five times the load capacity or 125 times the life of conventional linear bearings. This increase in bearing performance significantly reduces downtime and maintenance, while increasing machine reliability. When replacing v-ways and flat-ways, XR Ball Bushing Bearings allow travel speeds up to 5 ft./s and accelerations up to 225 ft./s<sup>2</sup> without a sharp increase in power consumption. XR Ball Bushing Bearings also provide three times the rigidity of conventional Ball Bushing Bearings, reducing deflection in critical machining applications. Pillow blocks are available with factory installed XR Ball Bushing Bearings and integral seals. 60 Case LinearRace shafting available pre-mounted on standard extra rigid LinearRace support rails. See Page 90.



#### RoundWay® Linear Roller Bearings

**Low-friction roller bearings with up to 20 times the load capacity of conventional linear bearings.**

These patented, self-aligning linear roller bearings have more than 20 times the load capacity of a conventional linear ball bearing. This dramatic increase in bearing load capacity allows designers to optimize system compactness and minimize hardware costs. Combining the self-aligning feature with the RoundRail Advantage minimizes installation time and assures trouble-free operation. RoundWay bearings can achieve operating speeds up to 10 ft./s without the derating factors commonly seen with linear guides. When normal machine maintenance is required, RoundWay bearings can be quickly and cost-effectively replaced, without scrapping the entire system – a major problem when servicing some linear guides. See Page 97.

# Thomson Linear Motion Components

## The RoundRail Advantage...



### FluoroNyliner® Bushing Bearings

#### Thomson FluoroNyliner Bushing Bearings offer:

- High performance in contaminated, washdown or submerged environments.
- Proprietary, self-lubricating, composite bearing liner TEP 950.
- Low friction, ideally suited for linear and rotary motion.
- Precision-machined aluminum sleeve.
- Excellent performance in high-vibration and mechanical shock applications.
- Corrosion resistance.
- Product availability in industry standard sizes from 0.25" to 2.00".
- Eight bearing configurations, including closed, open, self-aligning, precision and compensated IDs.
- Load capacities up to 14,000 lb.
- Integral seals.
- Closed, open, and flanged pillow blocks available in single or twin versions.

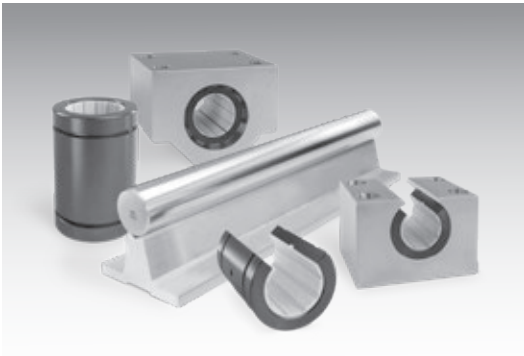

### Polymer Bushing Bearings

Thomson polymer bushing bearings offer linear motion designers a reliable, yet economical, option for machines in which moment load is non-critical or where contamination is a concern. These bearings are also useful for applications that require shafting that is incompatible with Thomson Ball Bushing Bearings such as aluminum or 316 stainless steel.

Handling loads up to 9000 N (2023 lbf), polymer bushing bearings provide a corrosion-resistant option for low-load, low-speed applications. When combined with round rail shafting, pillow blocks or other assembly components, polymer bushing bearings deliver a budget-friendly linear motion solution to a number of applications.

#### Polymer Bushing Bearings Applications

- Factory Automation
- Robotics
- Health and Fitness
- Medical Automation
- Woodworking
- Packaging
- Food and Beverage
- Vending

#### Polymer Bushing Bearings Highlights

- Available in sizes of 6 to 50 mm (closed) and 10 to 50 mm (open)
- Maintenance-free operation
- Polymer liners reduce noise
- Dirt and dust resistant
- Anodized aluminum adapter
- Available with aluminum pillow blocks



# Self-Lubricating Linear Bearing Pillow Blocks



Thomson Lube for Life pillow blocks provide continuous bearing lubrication and enhanced protection for a broad range of applications. Self-lubricating cartridges are pressed into each end of the pillow block housing, and the linear bearing is lubricated initially with EP2 grease. The Lube for Life polymer is under constant pressure against the 60 Case® LinearRace® shafting, ensuring a film of lubricant between the ball bearings and the inner race.

### Features and Benefits

- Maintenance-free operation
- Eliminates need for expensive lubrication systems
- Available as an option for Thomson pillow block types:
  - Super and Super Smart Ball Bushing® Bearing
  - Open and closed
  - Single and twin
- Available as a retrofit kit for existing non self-lubricating pillow block assemblies

## Closed Self-Lubricating Pillow Block Assemblies (Dimensions in inches)

Nominal LinearRace Diameter	L1	L2 Single	L2 Twin
0.500	0.23	2.15	3.96
0.750	0.24	2.55	4.98
1.000	0.30	3.42	6.60
1.250	0.42	4.47	8.34
1.500	0.43	4.86	9.86

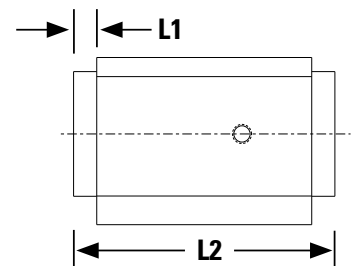
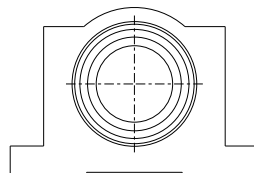

## Open Self-Lubricating

Nominal LinearRace Diameter	L1	L2 Single	L2 Twin
0.500	0.31	2.11	4.12
0.750	0.30	2.49	5.10
1.000	0.30	3.24	6.60
1.250	0.42	4.21	8.34
1.500	0.43	4.60	9.86

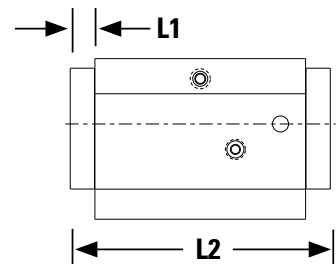
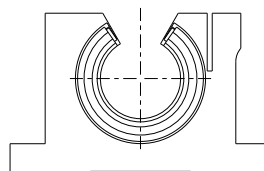

## Super Smart Ball Bushing Bearing Products



### Thomson Super Smart Ball Bushing Bearing products offer:

- Up to six times the load capacity or 216 times the travel life of conventional linear bearings.
- Twice the load capacity or eight times the travel life of industry standard Thomson Super Ball Bushing Bearings.
- A precision, super finished, dual track bearing plate for optimum system smoothness and performance.
- A universal self-alignment feature that compensates for misalignment of housing bores and 60 Case LinearRace shaft deflection, optimizes load distribution between ball tracks and assures uniform ball loading over the entire length of the bearing plate. Installation time and cost is minimized while bearing performance and life is maximized.
- A technologically advanced design that allows the bearing to maintain its diametrical fit-up when installed in a housing that is slightly out-of-round.
- Longer travel life and minimal machine downtime when replacing conventional linear bearings or the industry standard Super Ball Bushing Bearing.
- The RoundRail Advantage combined with universal self-alignment, eliminating the need for derating factors commonly required when using linear guides.
- A coefficient of friction as low as .001. This allows the use of smaller, less expensive motors, belts, gears and ball screws when replacing high-friction, plain bearings.
- Closed and open configurations.
- Double-lip integral wipers that keep out dirt while retaining lubrication. Travel life is maximized.
- Steady state travel speeds up to 10 ft./s and accelerations to 450 ft./s without the use of derating factors.



Super Smart Ball Bushing® Bearings represent a major advancement in linear bearing technology worldwide. These offer twice the load capacity or eight times the travel life of the industry standard Thomson Super Ball Bushing bearing. An enormous technological breakthrough, considering the Super Ball Bushing bearing already offers three times the load capacity or 27 times the travel life of conventional linear bearings.

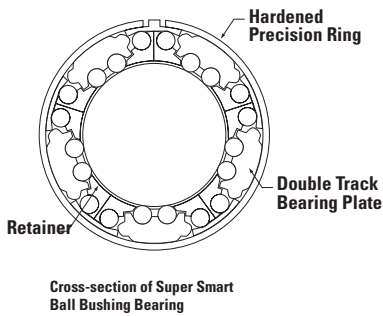

Figure 1  
Cross-section of Super Smart Ball Bushing Bearing

### Technologically Advanced Design

The load carrying component of the Super Smart Ball Bushing Bearing is the combination of four hardened bearing quality steel components (Figures 1 & 2).

The first component is the steel outer ring, which allows the bearing to maintain its diametrical fit-up even when installed in a housing that is slightly out-of-round. The unique ring design also allows for bearing adjustment and the removal of diametrical clearance. The second component is the precision, super-finished, double-track bearing plate that provides twice the load capacity and features universal self alignment.

The third component is the rolling element. Each Super Smart Ball Bushing Bearing utilizes precision ground balls manufactured to the highest quality standards for roundness and sphericity. The result is maximum load capacity, travel life and performance.

The last component is the 60 Case® LinearRace® shaft that acts as the inner race to the Super Smart Ball Bushing Bearing. Each 60 Case LinearRace shaft is manufactured to the highest quality standards for roundness, straightness, surface finish and hardness. Roundness is held under 80 millionths of an inch; straightness to .001 inches per foot; surface finish under 8 microinch and hardness of 60 HRC minimum. The combination of inner and outer race or 60 Case LinearRace shaft and Super Smart Ball Bushing Bearing provides the basis for the RoundRail Advantage.

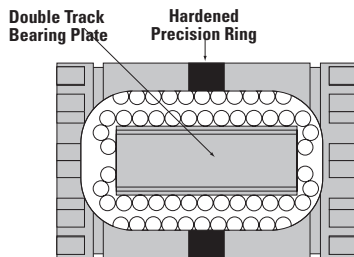
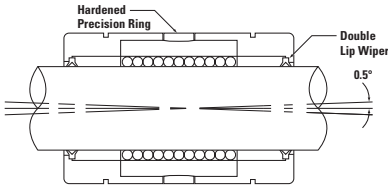

Figure 2

### The RoundRail Advantage

The RoundRail Advantage is the inherent ability of a Super Smart Ball Bushing Bearing system to accommodate torsional misalignment (caused by inaccuracies in carriage or base machining or by machine deflection) with little increase in stress to bearing components. Installation time and cost are minimized and system performance is maximized.

Figure 3



### Universal Self-Alignment

The bearing plate of the Super Smart Ball Bushing Bearing is designed with many unique and technologically advanced features. The universal self-alignment feature assures that the Super Smart Ball Bushing Bearing will achieve maximum performance regarding load capacity, travel life, smooth operation and coefficient of friction. The three components that make up universal self-alignment are **Rock**, **Roll** and **Yaw**.

Figure 4

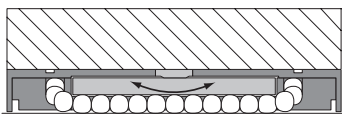

Closeup of hardened precision ring, showing how the bearing plate self aligns (rocks) about the curved surface of the ring.

### Rock

The bearing plate is designed to rock 0.5° about the hardened precision ground outer ring (Figures 3 & 4). This self-aligning feature allows the Super Smart Ball Bushing Bearing to absorb misalignment caused by inaccuracies in housing bore alignment or 60 Case LinearRace shaft deflection. This rocking capability provides smooth entry and exit of the precision balls into and out of the load zone, assuring a constant low coefficient of friction. By compensating for misalignment, each bearing ball in the load carrying area is uniformly loaded providing maximum load capacity.

Figure 5

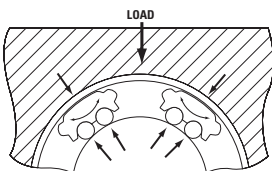

Closeup of double track bearing plates showing how they self align (roll) to evenly distribute the load on each of their two ball tracks.

### Roll

The second key design feature of the Super Smart Ball Bushing Bearing plate is its ability to **Roll**. The bearing plate is designed with the radius of its outer surface smaller than the inside radius of the precision outer ring (Figure 5). This allows the bearing plate to compensate for torsional misalignment and evenly distribute the load on each of its two ball tracks. The roll component assures maximum load capacity and travel life.

Figure 6

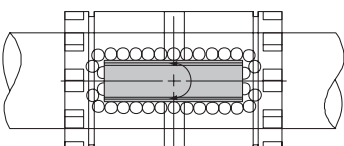

Bearing plates rotate about their center to prevent skewing relative to the 60 Case LinearRace shaft.

### Yaw

The shape formed by the **Rock** and **Roll** features allows the Super Smart Ball Bushing Bearing plate to rotate about its center (Figure 6). This allows the Super Smart Ball Bushing Bearing to absorb skew caused by misalignment. The result is a constant low coefficient of friction and maximum bearing performance.



# The Super Smart Advantage

## Advantage: Load Capacity

The Super Smart Ball Bushing® Bearing provides twice the load capacity of the industry standard Thomson Super Ball Bushing Bearing and six times the load capacity of conventional linear bearings.

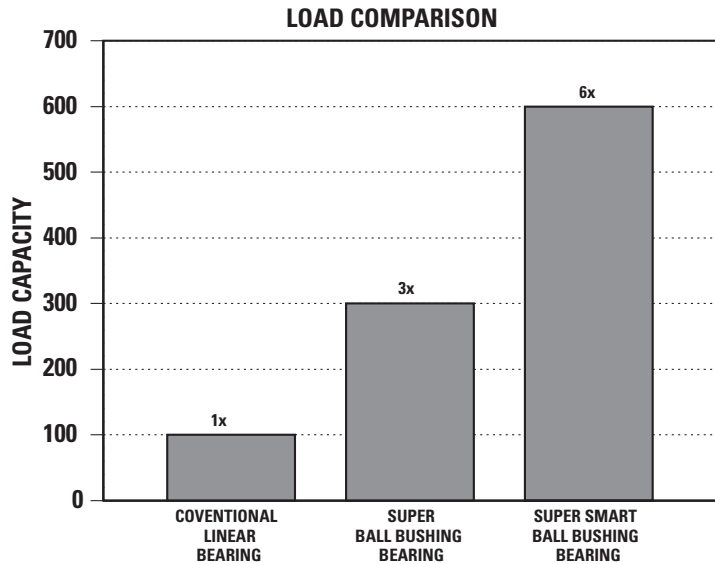

## Advantage: Travel Life

The Super Smart Ball Bushing Bearing provides eight times the travel life of the industry standard Thomson Super Ball Bushing bearing and 216 times the travel life of conventional linear bearings.

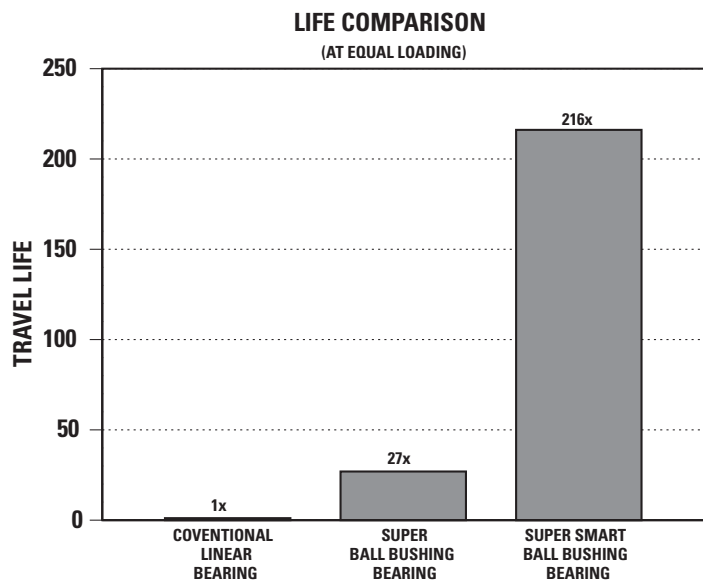

# Part Number Description and Specification

## Super Smart Ball Bushing Bearings (Closed Type) for End-Supported Applications

### SSU16WW-CR

Type	Description	Size	Nominal Diameter	Option	Description	Ball Options
SSU	Super Smart Ball Bushing bearings	8	.500	-	No Wipers	Option Description CR Corrosion Resistant NB Nylon Balls NBA Alternating Nylon Balls
		10	.625	W	One Integral Wiper	<b>Lube Options</b> DP Dry Pack LL Lubricated with Thomson Linear Lube
		12	.750	WW	Two Integral Wipers	<b>Other Options</b> RP Roll Pack (no box)
		16	1.000			
		20	1.250			
		24	1.500			

## Super Smart Ball Bushing Pillow Blocks (Closed Type) for End-Supported Applications

### SSUPB16-CR

Type	Description	Size	Nominal Diameter	Ball Options
SSUPB	Super Smart Ball Bushing Pillow Blocks	8	.500	Option Description CR Corrosion Resistant NB Nylon Balls NBA Alternating Nylon Balls
SSUPBA	Super Smart Ball Bushing Adjustable Pillow Blocks	10	.625	<b>Lube Options</b> DP Dry Pack LL Lubricated with Thomson Linear Lube L4L Lube for Life
SSUTWN	Super Smart Ball Bushing Twin Pillow Blocks	12	.750	
SSUTWNA	Super Smart Ball Bushing Twin Adjustable Pillow Blocks	16	1.000	
SSUFB	Super Smart Ball Bushing Flanged Pillow Blocks	20	1.250	
SSUTFB	Super Smart Ball Bushing Flanged Twin Pillow Blocks	24	1.500	

Not all options are available in all sizes.  
See catalog pages or contact Thomson Customer Support for combination availability.  
For additional information on bearing options, see page 267.



# Super Smart Ball Bushing® Bearings (Closed Type) for End-Supported Applications

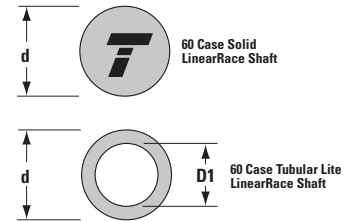
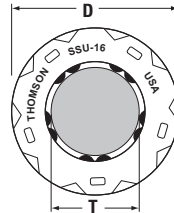
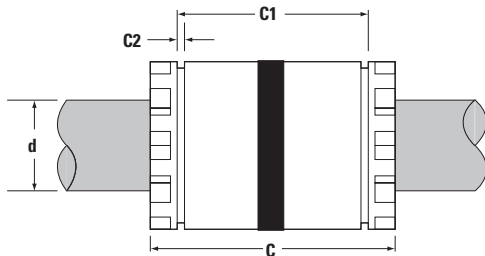
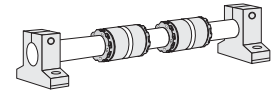

## Super Smart Ball Bushing Bearings (Closed Type) and 60 Case® LinearRace® Shafting (Dimensions in inches)

Part Number <sup>(2)</sup>				Nominal Diameter	Length C	C1	C2 min.	Number of Ball Circuits	Ball Bushing bearing Mass lb	60 Case LinearRace Minimum Depth of Hardness	60 Case Solid LinearRace Mass lb/in	60 Case Tubular Lite LinearRace Mass lb/in	60 Case Tubular Lite LinearRace ID D1
Without Integral Wipers	With one Integral Wiper	With two Integral Wipers	60 Case Linear Race										
SS6U8	SS6U8W	SS6U8WW	1/2 L	.500	1.250/1.230	1.032/1.012	.050	6	.07	.04	.06	–	–
SSU10	SSU10W	SSU10WW	5/8 L	.625	1.500/1.480	1.125/1.095	.055	10	.12	.04	.09	–	–
SSU12	SSU12W	SSU12WW	3/4 L	.750	1.625/1.605	1.285/1.255	.055	10	.16	.06	.13	.08	.46/.41
SSU16	SSU16W	SSU16WW	1 L	1.000	2.250/2.230	1.901/1.871	.068	10	.29	.08	.22	.16	.62/.56
SSU20	SSU20W	SSU20WW	1 1/4 L	1.250	2.625/2.600	2.031/1.991	.068	10	.52	.08	.35	–	–
SSU24	SSU24W	SSU24WW	1 1/2 L	1.500	3.000/2.970	2.442/2.402	.086	10	.99	.08	.50	.33	.93/.84

Part Number <sup>(2)</sup>			Working Bore Diameter T	Recommended Housing Bore		60 Case LinearRace Diameter d	Ball Bushing bearing/60 Case LinearRace Fit Up ‡		Dynamic <sup>(1)</sup> Load Capacity lb <sub>f</sub>
Without Integral Wipers	With one Integral Wiper	With two Integral Wipers		Fixed D	Adjustable D		Fixed Diameter Housing	Adjustable Diameter Housing (Before Adjustment)	
SS6U8	SS6U8W	SS6U8WW	.5000/.4995	.8755/.8750	.8760/.8750	.4995/.4990	.0015C/.0000	.002C/.0000	265
SSU10	SSU10W	SSU10WW	.6250/.6245	1.1255/1.1250	1.1260/1.1250	.6245/.6240	.0015C/.0000	.002C/.0000	620
SSU12	SSU12W	SSU12WW	.7500/.7495	1.2505/1.2500	1.2510/1.2500	.7495/.7490	.0015C/.0000	.002C/.0000	1130
SSU16	SSU16W	SSU16WW	1.0000/.9995	1.5630/1.5625	1.5635/1.5625	.9995/.9990	.0015C/.0000	.002C/.0000	1900
SSU20	SSU20W	SSU20WW	1.2500/1.2494	2.0008/2.0000	2.0010/2.0000	1.2495/1.2490	.0018C/.0001P	.002C/.0001P	2350
SSU24	SSU24W	SSU24WW	1.5000/1.4994	2.3760/2.3750	2.3760/2.3750	1.4994/1.4989	.0021C/.0000	.0021C/.0000	3880

‡ P = Preload, C = Clearance

(1) The Dynamic Load Capacity is based on a rated travel life of 2 million inches. The actual Dynamic Load Capacity can be affected by the orientation of the bearing or the direction of the applied load. For Dynamic Load Correction Factors, see following polar graphs.

(2) For part number description and specifications, see page 25. For specifications on seals and retaining rings, see the Accessories section.

Note: For additional technical information, see the Engineering section beginning on page 256.

### Load/Life Graph

(Lines indicate limiting load for given Ball Bushing Bearing)

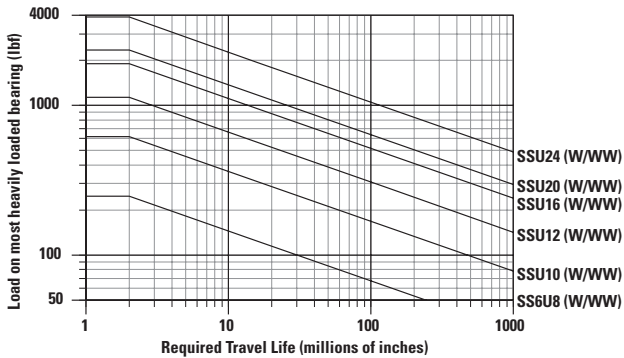

#### Determining Ball Bushing Bearing Size

To determine the proper Ball Bushing Bearing size, enter the chart with the maximum load of the most heavily loaded bearing and the required travel life. Mark where the two lines intersect. All Ball Bushing Bearing sizes that pass through or above and to the right of this point may be suitable for this application.

**Note:** For the purpose of using this chart, load on most heavily loaded bearing = maximum applied load/ $K_0$ . Where  $K_0$  can be determined from the Polar Graph to the right.

### Polar Graphs

The actual dynamic load capacity of a Ball Bushing Bearing is determined by the orientation of the bearing or direction of the applied load. The load correction factor  $K_0$  is found by knowing the direction of the applied load relative to the orientation of the bearings ball tracks and referring to the polar graph. To determine the actual dynamic load capacity, multiply the proper correction factor by the dynamic load capacity listed in the product table on the previous page.

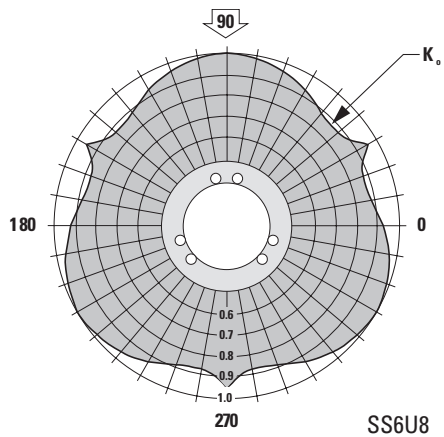
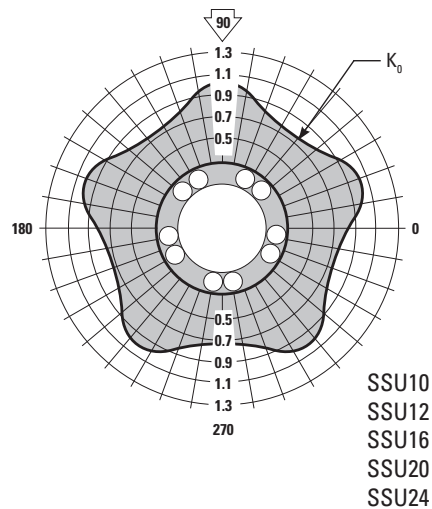



# Super Smart Ball Bushing® Pillow Blocks (Closed and Adjustable Type) for End-Supported Applications

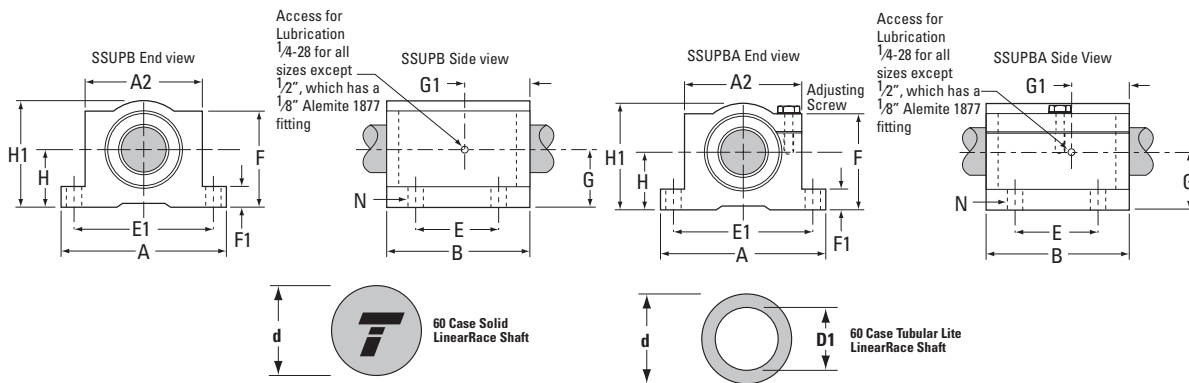
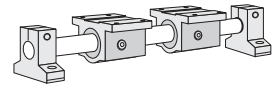

## Super Smart Ball Bushing Pillow Blocks (Closed & Adjustable Types, seal at both ends) and LinearRace® (Dim. in inches)

Part Number <sup>(2)</sup>		60 Case LinearRace	Nominal Diameter	H ±.003	H1	60 Case LinearRace Diameter d	60 Case LinearRace Minimum Depth of Hardness	60 Case Solid LinearRace Mass lb/in	60 Case Tubular Lite LinearRace Mass lb/in	60 Case Tubular Lite LinearRace ID D1
Fixed	Adjustable									
SS6UPB8	SS6UPBA8	1/2 L	.500	.687	1.25	.4995/.4990	.04	.06	—	—
SSUPB10	SSUPBA10	5/8 L	.625	.875	1.63	.6245/.6240	.04	.09	—	—
SSUPB12	SSUPBA12	3/4 L	.750	.937	1.75	.7495/.7490	.06	.13	.08	.46/.41
SSUPB16	SSUPBA16	1 L	1.000	1.187	2.19	.9995/.9990	.08	.22	.16	.62/.56
SSUPB20	SSUPBA20	1 1/4 L	1.250	1.500	2.81	1.2495/1.2490	.08	.35	—	—
SSUPB24	SSUPBA24	1 1/2 L	1.500	1.750	3.25	1.4994/1.4989	.08	.50	.33	.93/.84

Part Number <sup>(2)</sup>		A	A2	B	E ±.010	E1 ±.010	F	F1	G	G1	N		Pillow Block Mass lb	Dynamic <sup>(1)</sup> Load Capacity lb <sub>f</sub>
Fixed	Adjustable										Hole	Bolt		
SS6UPB8	SS6UPBA8	2.00	1.38	1.69	1.000	1.688	1.13	.25	.97	.44	.16	#6	.23	265
SSUPB10	SSUPBA10	2.50	1.75	1.94	1.125	2.125	1.44	.28	1.20	.69	.19	#8	.51	620
SSUPB12	SSUPBA12	2.75	1.88	2.06	1.250	2.375	1.56	.31	.94	.78	.19	#8	.62	1130
SSUPB16	SSUPBA16	3.25	2.38	2.81	1.750	2.875	1.94	.38	1.19	.91	.22	#10	1.24	1900
SSUPB20	SSUPBA20	4.00	3.00	3.63	2.000	3.500	2.50	.44	1.50	1.37	.22	#10	2.57	2350
SSUPB24	SSUPBA24	4.75	3.50	4.00	2.500	4.125	2.88	.50	1.75	1.13	.28	.25	3.94	3880

(1) The Dynamic Load Capacity is based on a rated travel life of 2 million inches. The actual Dynamic Load Capacity can be affected by the orientation of the bearing or the direction of the applied load. For Dynamic Load Correction Factors, see following polar graphs.

(2) For part number description and specifications, see page 25.

Note: For additional technical information, see the Engineering section beginning on page 256.

## Load/Life Graph

(Lines indicate limiting load for given Ball Bushing Bearing)

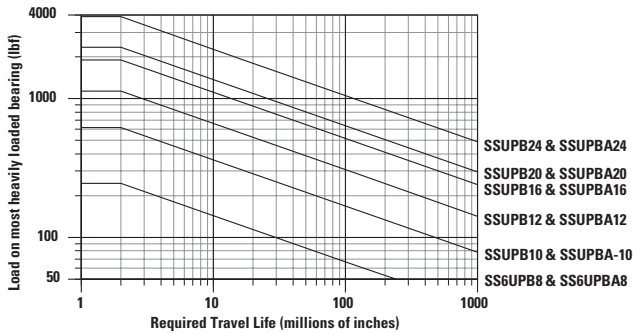

### Determining Ball Bushing Bearing Size

To determine the proper Ball Bushing Bearing size, enter the chart with the maximum load of the most heavily loaded bearing and the required travel life. Mark where the two lines intersect. All Ball Bushing Bearing sizes that pass through or above and to the right of this point may be suitable for this application.

**Note:** For the purpose of using this chart, load on most heavily loaded bearing = maximum applied load/ $K_0$ . Where  $K_0$  can be determined from the Polar Graph to the right.

## Polar Graphs

The actual dynamic load capacity of a Ball Bushing Bearing is determined by the orientation of the bearing or direction of the applied load. The load correction factor  $K_0$  is found by knowing the direction of the applied load relative to the orientation of the bearings ball tracks and referring to the polar graph. To determine the actual dynamic load capacity, multiply the proper correction factor by the dynamic load capacity listed in the product table on the previous.

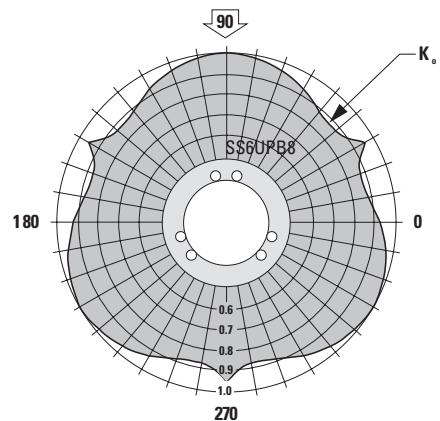
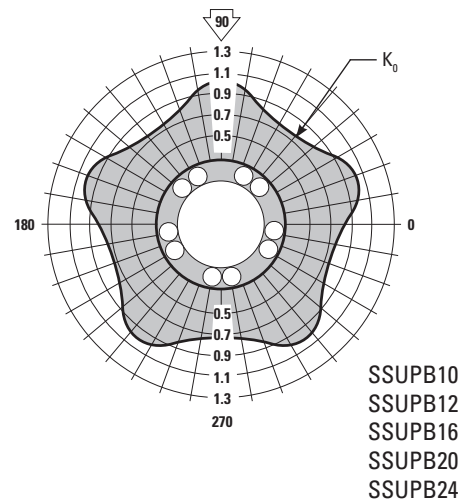



# Super Smart Ball Bushing® Twin Pillow Blocks (Closed and Adjustable Type) for End-Supported Applications

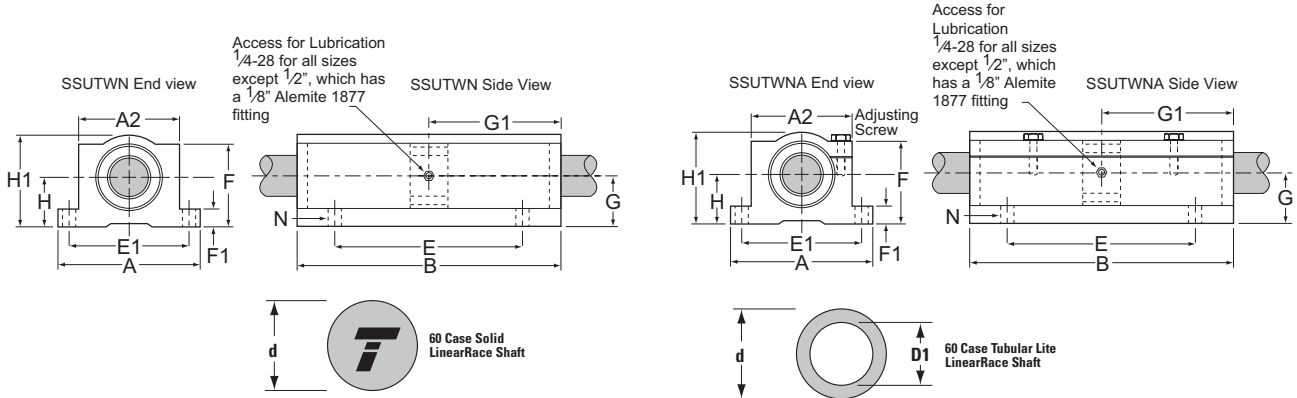
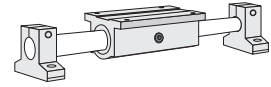

## Super Smart Ball Bushing Twin Pillow Blocks (Closed Type, seal at both ends) and 60 Case® LinearRace® Shaft (Dim. in in.)

Part Number <sup>(2)</sup>		60 Case LinearRace	Nominal Diameter	H ±.003	H1	60 Case LinearRace Diameter d	60 Case LinearRace Minimum Depth of Hardness	60 Case Solid LinearRace Mass lb/in	60 Case Tubular Lite LinearRace Mass lb/in	60 Case Tubular Lite LinearRace ID D1
Fixed	Adjustable									
SS6UTWN8	SS6UTWNA8	1/2 L	.500	.687	1.25	.4995/.4990	.04	.06	—	—
SSUTWN10	SSUTWNA10	5/8 L	.625	.875	1.63	.6245/.6240	.04	.09	—	—
SSUTWN12	SSUTWNA12	3/4 L	.750	.937	1.75	.7495/.7490	.06	.13	.08	.46/.41
SSUTWN16	SSUTWNA16	1 L	1.000	1.187	2.19	.9995/.9990	.08	.22	.16	.62/.56
SSUTWN20	SSUTWNA20	1 1/4 L	1.250	1.500	2.81	1.2495/1.2490	.08	.35	—	—
SSUTWN24	SSUTWNA24	1 1/2 L	1.500	1.750	3.25	1.4994/1.4989	.08	.50	.33	.93/.84

Part Number <sup>(2)</sup>		A	A2	B	E ±.010	E1 ±.010	F	F1	G	G1	N		Pillow Block Mass lb	Dynamic <sup>(1)</sup> Load Capacity lb <sub>r</sub>
Fixed	Adjustable										Hole	Bolt		
SS6UTWN8	SS6UTWNA8	2.00	1.38	3.50	2.500	1.688	1.13	.25	.59	1.75	.16	#6	.46	530
SSUTWN10	SSUTWNA10	2.50	1.75	4.00	3.000	2.125	1.44	.28	.85	2.00	.19	#8	1.02	1240
SSUTWN12	SSUTWNA12	2.75	1.88	4.50	3.500	2.375	1.56	.31	.94	2.25	.19	#8	1.24	2260
SSUTWN16	SSUTWNA16	3.25	2.38	6.00	4.500	2.875	1.94	.38	1.19	3.00	.22	#10	2.48	3800
SSUTWN20	SSUTWNA20	4.00	3.00	7.50	5.500	3.500	2.50	.44	1.50	3.75	.22	#10	5.14	4700
SSUTWN24	SSUTWNA24	4.75	3.50	9.00	6.500	4.125	2.88	.50	1.75	4.50	.28	.25	8.08	7760

(1) The Dynamic Load Capacity is based on a rated travel life of 2 million inches. The actual Dynamic Load Capacity can be affected by the orientation of the bearing or the direction of the applied load. For Dynamic Load Correction Factors, see following polar graphs. Dynamic load capacity is based on two bearings equally loaded.

(2) For part number description and specifications, see page 25.

Note: For additional technical information, see the Engineering section beginning on page 256.

### Load/Life Graph

(Lines indicate limiting load for given Ball Bushing Bearing)

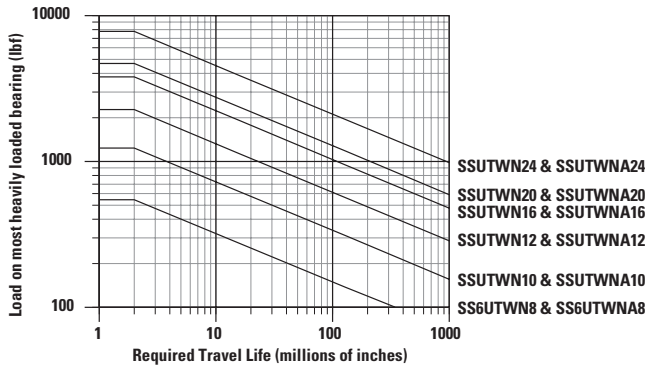

#### Determining Ball Bushing Bearing Size

To determine the proper Ball Bushing Bearing size, enter the chart with the maximum load of the most heavily loaded bearing and the required travel life. Mark where the two lines intersect. All Ball Bushing Bearing sizes that pass through or above and to the right of this point may be suitable for this application.

**Note:** For the purpose of using this chart, load on most heavily loaded bearing = maximum applied load/ $K_0$ . Where  $K_0$  can be determined from the Polar Graph to the right.

### Polar Graphs

The actual dynamic load capacity of a Ball Bushing Bearing is determined by the orientation of the bearing or direction of the applied load. The load correction factor  $K_0$  is found by knowing the direction of the applied load relative to the orientation of the bearings ball tracks and referring to the polar graph. To determine the actual dynamic load capacity, multiply the proper correction factor by the dynamic load capacity listed in the product table on the previous page.

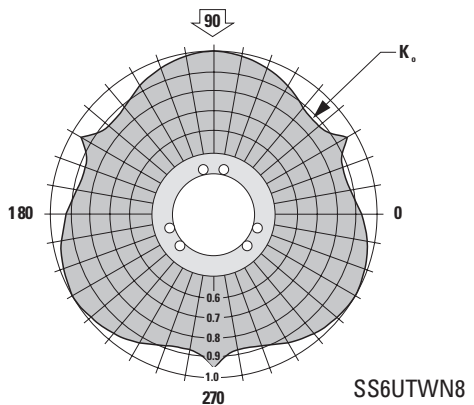
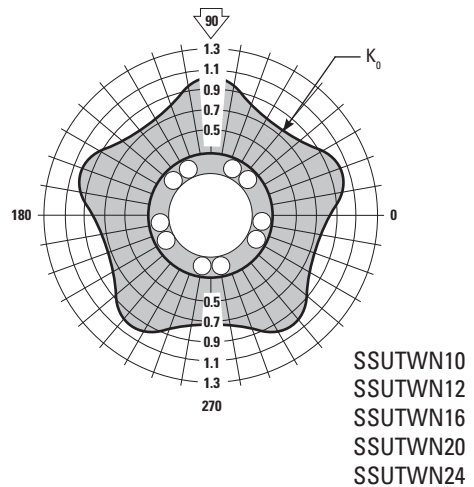



# Super Smart Ball Bushing® Flanged Single and Twin Pillow Blocks for End-Supported Applications

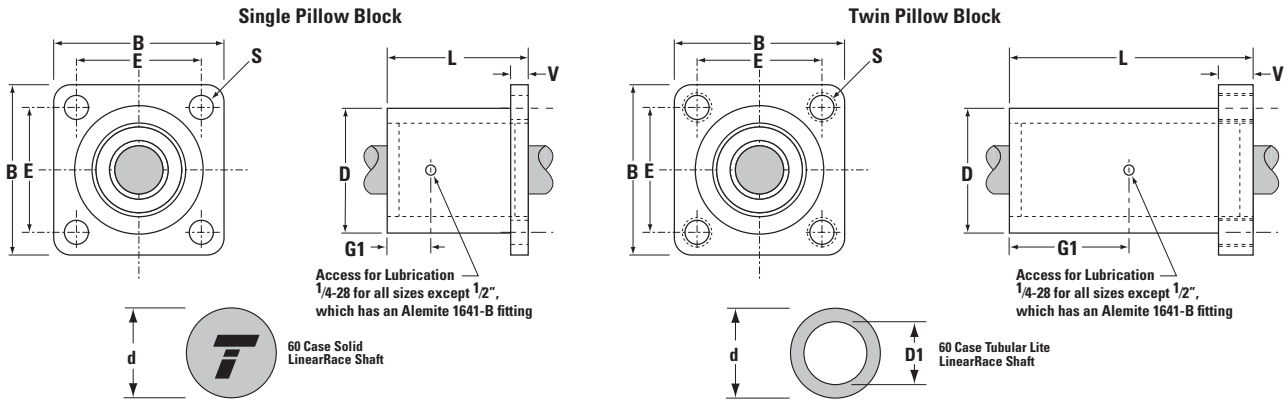
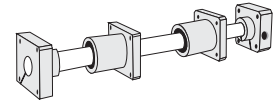

## Super Smart Ball Bushing Flanged Pillow Blocks and 60 Case® LinearRace® Shaft (Dimensions in inches)

Part Number <sup>(2)</sup>		Nominal Diameter	B	E ±.010	L	D	V	G1	S Hole Dia.	60 Case LinearRace Diameter d	60 Case LinearRace Minimum Depth of Hardness	60 Case Solid LinearRace Mass lb/in	60 Case Tubular Lite LinearRace Mass lb/in	60 Case Tubular Lite LinearRace ID D1	Pillow Block Mass lb	Dyn. <sup>(1)</sup> Load Cap. lb <sub>f</sub>
Super Smart Ball Bushing Flanged Pillow Block	60 Case LinearRace															
SS6UFB8	1/2 L	.500	1.63	1.250	1.69	1.25	.25	.72	.19	.4995/.4990	.04	.06	—	—	.23	265
SSUFB12	3/4 L	.750	2.38	1.750	2.06	1.75	.38	.89	.22	.7495/.7490	.06	.13	.08	.460/.416	.52	1130
SSUFB16	1 L	1.000	2.75	2.125	2.81	2.25	.50	1.27	.28	.9995/.9990	.08	.22	.16	.629/.569	1.04	1900
SSUFB20	1 1/4 L	1.250	3.50	2.750	3.63	3.00	.63	1.67	.35	1.2495/1.2490	.08	.35	—	—	2.21	2350
SSUFB24	1 1/2 L	1.500	4.00	3.125	4.00	3.62	.75	1.86	.41	1.4994/1.4989	.08	.50	.33	.93/.84	3.68	3880

## Super Smart Ball Bushing Flanged Twin Pillow Blocks and 60 Case LinearRace Shaft (Dimensions in inches)

Part Number <sup>(2)</sup>		Nominal Diameter	B	E ±.010	L	D	V	G1	S Thread	60 Case LinearRace Diameter d	60 Case LinearRace Minimum Depth of Hardness	60 Case Solid LinearRace Mass lb/in	60 Case Tubular Lite LinearRace Mass lb/in	60 Case Tubular Lite LinearRace ID D1	Pillow Block Mass lb	Dynamic <sup>(1)</sup> Load Cap. lb <sub>f</sub>
Super Smart Ball Bushing Flanged Twin Pillow Block	60 Case LinearRace															
SS6UTFB8	1/2 L	.500	1.63	1.250	3.20	1.25	.90	1.48	1/4-20	.4995/.4990	.04	.06	—	—	.45	530
SSUTFB12	3/4 L	.750	2.38	1.750	3.95	1.75	.90	1.98	1/4-20	.7495/.7490	.06	.13	.08	.460/.416	1.05	2260
SSUTFB16	1 L	1.000	2.75	2.125	5.33	2.25	.90	2.67	5/16-18	.9995/.9990	.08	.22	.16	.629/.569	1.95	3800
SSUTFB20	1 1/4 L	1.250	3.50	2.750	6.70	3.00	.90	3.35	5/16-18	1.2495/1.2490	.08	.35	—	—	4.06	4700
SSUTFB24	1 1/2 L	1.500	4.00	3.125	7.50	3.62	1.00	3.75	3/8-16	1.4994/1.4989	.08	.50	.33	.93/.84	6.84	7760

(1) The Dynamic Load Capacity is based on a rated travel life of 2 million inches. The actual Dynamic Load Capacity can be affected by the orientation of the bearing or the direction of the applied load. For Dynamic Load Correction Factors, see following polar graphs. Dynamic load capacity for Twin configuration is based on two bearings equally loaded.

(2) For part number description and specifications, see page 25.

Note: For additional technical information, see the Engineering section beginning on page 256.

### Load/Life Graph

(Lines indicate limiting load for given Ball Bushing Bearing)

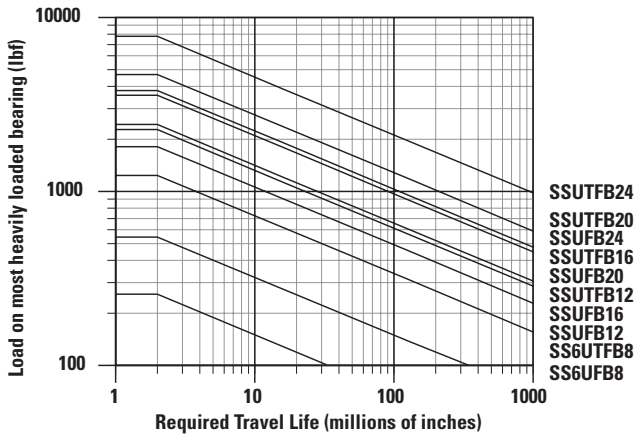

#### Determining Ball Bushing Bearing Size

To determine the proper Ball Bushing Bearing size, enter the chart with the maximum load of the most heavily loaded bearing and the required travel life. Mark where the two lines intersect. All Ball Bushing Bearing sizes that pass through or above and to the right of this point may be suitable for this application.

**Note:** For the purpose of using this chart, load on most heavily loaded bearing = maximum applied load/ $K_0$ . Where  $K_0$  can be determined from the Polar Graph to the right.

### Polar Graphs

The actual dynamic load capacity of a Ball Bushing Bearing is determined by the orientation of the bearing or direction of the applied load. The load correction factor  $K_0$  is found by knowing the direction of the applied load relative to the orientation of the bearings ball tracks and referring to the polar graph. To determine the actual dynamic load capacity, multiply the proper correction factor by the dynamic load capacity listed in the product table on the previous page.

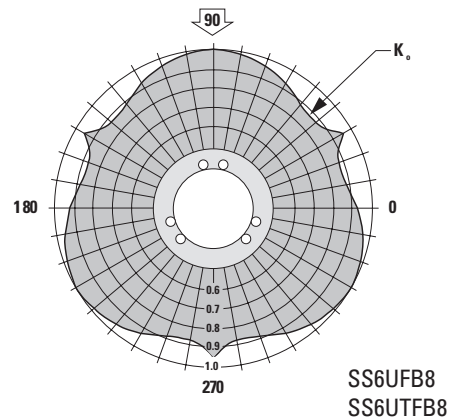
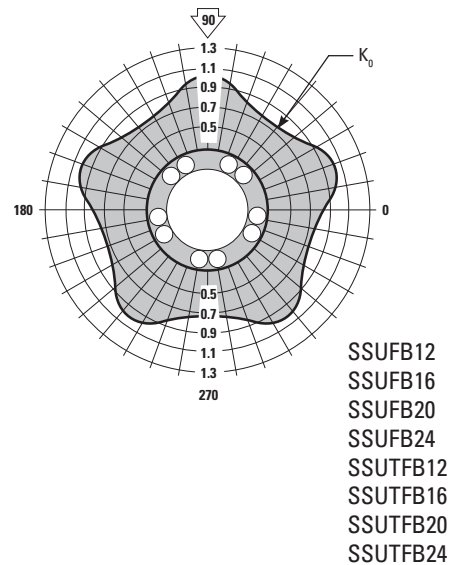



## Part Number Description and Specification

### Super Smart Ball Bushing® Bearings (Open Type) for Continuously Supported Applications

#### SSU160PNWW-CR

Type	Description	Size	Nominal Diameter	Option	Description	Ball Options
SSU	Super Smart Ball Bushing bearings	8	.500	-	No Wipers	Option Description CR Corrosion Resistant NB Nylon Balls NBA Alternating Nylon Balls
		10	.625	W	One Integral Wiper	
		12	.750	WW	Two Integral Wipers	
		16	1.000			
		20	1.250			
		24	1.500			
Type	Description			Type	Description	Lube Options
OPN	Open for continuously supported applications			DP	Dry Pack	
				LL	Lubricated with Thomson Linear Lube	
				Other Options		
				RP	Roll Pack (no box)	

### Super Smart Ball Bushing Pillow Blocks (Open Type) for Continuously Supported Applications

#### SSUPB016-CR

Type	Description	Size	Nominal Diameter	Ball Options	
SSUPB0	Super Smart Ball Bushing Pillow Blocks (Open Type)	8	.500	Option Description CR Corrosion Resistant NB Nylon Balls NBA Alternating Nylon Balls	
SSUTWNO	Super Smart Ball Bushing Twin Pillow Blocks (Open Type)	10	.625		
		12	.750		
SSURPBO	Super Smart Ball Bushing Rigid Steel Pillow Blocks (Open Type)	16	1.000		
		20	1.250		
		24	1.500		
				Lube Options	
				DP	Dry Pack
				LL	Lubricated with Thomson Linear Lube
				L4L	Lube for Life

Not all options are available in all sizes.

See catalog pages or contact Thomson Customer Support for combination availability.

For additional information on bearing options, see page 267.

# Super Smart Ball Bushing Bearings (Open Type) for Continuously Supported Applications

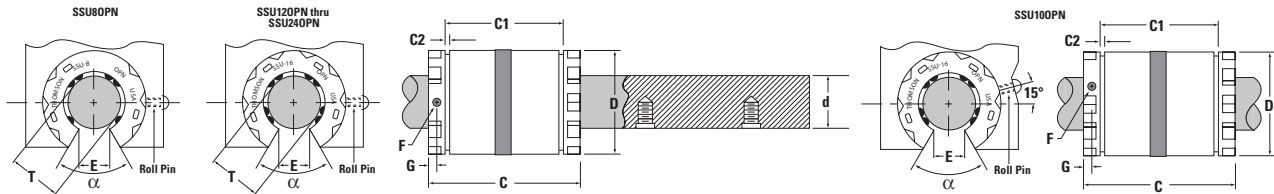
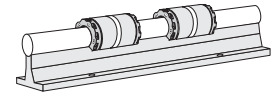

**Super Smart Ball Bushing Bearings (Open Type) and 60 Case® LinearRace® Shafting** (Dimensions in inches)

Part Number <sup>(1)</sup>				Nom. Dia.	Length C	C1	C2 min.	Min. Slot Width E	Retention Hole		Angle deg $\alpha$	Number of Ball Circuits	Ball Bushing bearing Mass lb
Without Integral Wipers	With one Integral Wiper	With two Integral Wipers	60 Case Linear Race*						Di. F	Loc. G			
SSU80PN	SSU80PNW	SSU80PNWW	1/2 L PD	.500	1.250/1.230	1.032/1.012	.050	.31	.13	.62	90	6	.07
SSU100PN	SSU100PNW	SSU100PNWW	5/8 L PD	.625	1.500/1.480	1.125/1.095	.055	.34	.11	.13	60	8	.09
SSU120PN	SSU120PNW	SSU120PNWW	3/4 L PD	.750	1.625/1.605	1.285/1.255	.055	.41	.14	.13	60	8	.13
SSU160PN	SSU160PNW	SSU160PNWW	1 L PD	1.000	2.250/2.230	1.901/1.871	.068	.53	.14	.13	60	8	.24
SSU200PN	SSU200PNW	SSU200PNWW	1 1/4 L PD	1.250	2.625/2.600	2.031/1.991	.068	.62	.20	.19	50	8	.43
SSU240PN	SSU240PNW	SSU240PNWW	1 1/2 L PD	1.500	3.000/2.970	2.442/2.402	.086	.74	.20	.19	50	8	.80

\* 60 Case begins on page 176.

Part Number <sup>(1)</sup>			Working Bore Diameter T	Recommended Housing Bore Dia.		60 Case LinearRace Diameter d	Ball Bushing bearing/LinearRace Fit Up ‡		Dynamic <sup>(2)</sup> Load Capacity lb <sub>i</sub>
Without Integral Wipers	With one Integral Wiper	With two Integral Wipers		Fixed D	Adjustable D		Fixed Diameter Housing	Adjustable Diameter Housing (Before Adjustment)	
SSU80PN	SSU80PNW	SSU80PNWW	.5000/.4995	.8755/.8750	.8760/.8750	.4995/.4990	.0015C/.0000	.002C/.0000	360
SSU100PN	SSU100PNW	SSU100PNWW	.6250/.6245	1.1255/1.1250	1.1260/1.1250	.6245/.6240	.0015C/.0000	.002C/.0000	620
SSU120PN	SSU120PNW	SSU120PNWW	.7500/.7495	1.2505/1.2500	1.2510/1.2500	.7495/.7490	.0015C/.0000	.002C/.0000	1130
SSU160PN	SSU160PNW	SSU160PNWW	1.0000/.9995	1.5630/1.5625	1.5635/1.5625	.9995/.9990	.0015C/.0000	.002C/.0000	1900
SSU200PN	SSU200PNW	SSU200PNWW	1.2500/1.2494	2.0008/2.0000	2.0010/2.0000	1.2495/1.2490	.0018C/.0001P	.002C/.0001P	2350
SSU240PN	SSU240PNW	SSU240PNWW	1.5000/1.4994	2.3760/2.3750	2.3760/2.3750	1.4994/1.4989	.0021C/.0000	.0021C/.0000	3880

‡ P = Preload, C = Clearance

(1) For part number description and specifications, see page 34.

(2) The Dynamic Load Capacity is based on a rated travel life of 2 million inches. The actual Dynamic Load Capacity can be affected by the orientation of the bearing or the direction of the applied load. For Dynamic Load Correction Factors, see following polar graphs.



## Load/Life Graph

(Lines indicate limiting load for given Ball Bushing® Bearing)

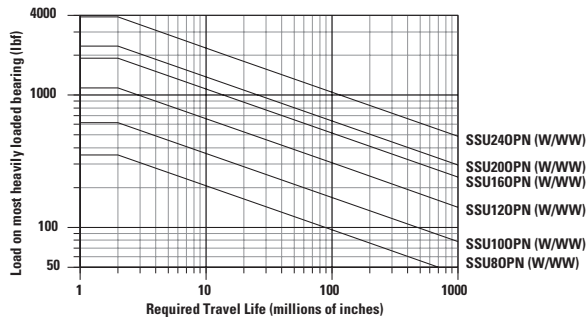

### Determining Ball Bushing Bearing Size

To determine the proper Ball Bushing Bearing size, enter the chart with the maximum load of the most heavily loaded bearing and the required travel life. Mark where the two lines intersect. All Ball Bushing Bearing sizes that pass through or above and to the right of this point may be suitable for this application.

**Note:** For the purpose of using this chart, load on most heavily loaded bearing = maximum applied load/ $K_0$ . Where  $K_0$  can be determined from the Polar Graph to the right.

**When using LSRA smart rail assemblies, the dynamic load capacity for side-loaded or pull-off applications must be derated by 75% or .25 times the dynamic load capacity.**

## Polar Graphs

The actual dynamic load capacity of a Ball Bushing Bearing is determined by the orientation of the bearing or direction of the applied load. The load correction factor  $K_0$  is found by knowing the direction of the applied load relative to the orientation of the bearings ball tracks and referring to the polar graph. To determine the actual dynamic load capacity, multiply the proper correction factor by the dynamic load capacity listed in the product table on the previous page.

**Note:** For Super Smart Ball Bushing® Bearings and other extremely high-load bearings, the bearing load capacity as indicated by the polar charts may be practically limited by the degree of shaft flexure acceptable or the capacity of the shaft rail assembly fasteners. In such cases, the loads should be kept below these practical limits, however, the full corresponding life capacity benefits are still realized.

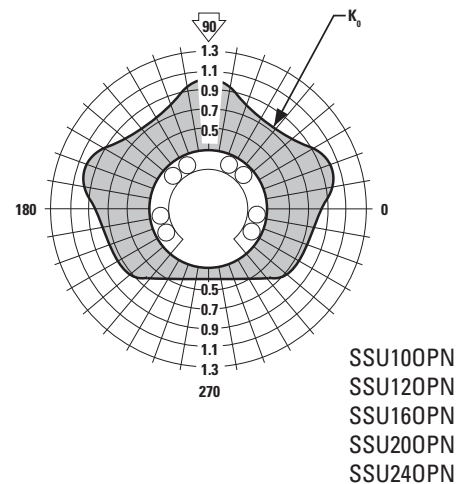
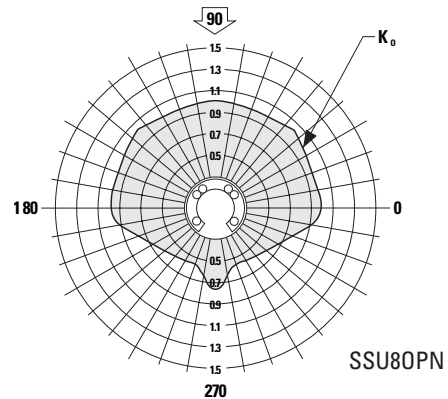

# Super Smart Ball Bushing Pillow Blocks (Open Type) for Continuously Supported Applications

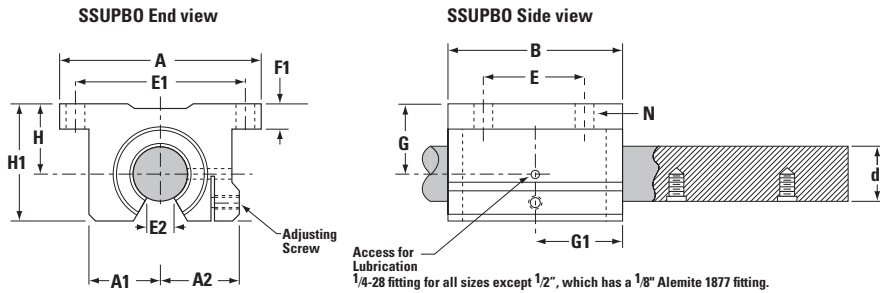
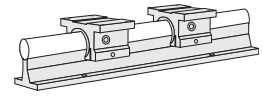

## Super Smart Ball Bushing Pillow Blocks (Open Type) and 60 Case® LinearRace® (Dimensions in inches)

Part Number <sup>(1)</sup>		Nominal Diameter	H ±.003	H1	60 Case LinearRace Diameter d
Super Smart Ball Bushing Pillow Block	60 Case LinearRace				
SSUPB08	1/2 L PD	.500	.687	1.13	.4995/.4990
SSUPB010	5/8 L PD	.625	.875	1.44	.6245/.6240
SSUPB012	3/4 L PD	.750	.937	1.56	.7495/.7490
SSUPB016	1 L PD	1.000	1.187	2.00	.9995/.9990
SSUPB020	1 1/4 L PD	1.250	1.500	2.50	1.2495/1.2490
SSUPB024	1 1/2 L PD	1.500	1.750	2.94	1.4994/1.4989

\* 60 Case begins on page 176.

Part Number <sup>(1)</sup>	Super Smart Ball Bushing Pillow Block			B	E ±.010	E1 ±.010	E2 min.	F1	G	G1	N Hole	N1 Bolt	Pillow Block Mass lb	Dynamic <sup>(2)</sup> Load Capacity lb <sub>i</sub>
	A	A1	A2											
SSUPB08	2.00	.69	.75	1.50	1.000	1.688	.31	.25	.50	.89	.16	#6	.23	360
SSUPB010	2.50	.88	.94	1.75	1.125	2.125	.34	.28	.55	.95	.19	#8	.41	620
SSUPB012	2.75	.94	1.00	1.88	1.250	2.375	.41	.31	.67	1.08	.19	#8	.51	1130
SSUPB016	3.25	1.19	1.25	2.63	1.750	2.875	.53	.38	.87	1.45	.22	#10	1.03	1900
SSUPB020	4.00	1.50	1.63	3.38	2.000	3.500	.62	.44	1.15	1.83	.22	#10	2.15	2350
SSUPB024	4.75	1.75	1.88	3.75	2.500	4.125	.74	.50	1.28	2.02	.28	.25	3.29	3880

(1) For part number description and specifications, see page 34.

(2) The Dynamic Load Capacity is based on a rated travel life of 2 million inches. The actual Dynamic Load Capacity can be affected by the orientation of the bearing or the direction of the applied load. For Dynamic Load Correction Factors, see following polar graphs.



## Load/Life Graph

(Lines indicate limiting load for given Ball Bushing® Bearing)

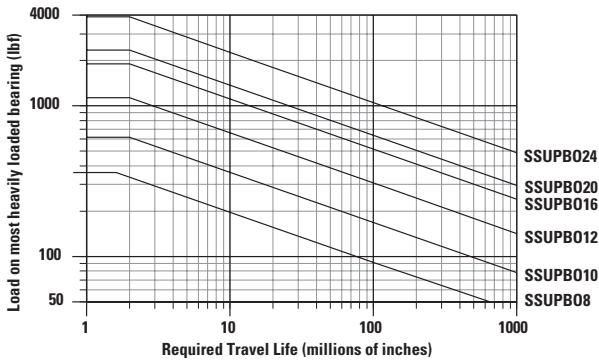

### Determining Ball Bushing Bearing Size

To determine the proper Ball Bushing Bearing size, enter the chart with the maximum load of the most heavily loaded bearing and the required travel life. Mark where the two lines intersect. All Ball Bushing Bearing sizes that pass through or above and to the right of this point may be suitable for this application.

**Note:** For the purpose of using this chart, load on most heavily loaded bearing = maximum applied load/ $K_0$ . Where  $K_0$  can be determined from the Polar Graph to the right.

## Polar Graphs

The actual dynamic load capacity of a Ball Bushing Bearing is determined by the orientation of the bearing or direction of the applied load. The load correction factor  $K_0$  is found by knowing the direction of the applied load relative to the orientation of the bearings ball tracks and referring to the polar graph. To determine the actual dynamic load capacity, multiply the proper correction factor by the dynamic load capacity listed in the product table on the previous page.

**Note:** For Super Smart Ball Bushing Bearings and other extremely high load bearings, the bearing load capacity as indicated by the polar charts may be practically limited by the degree of shaft flexure acceptable, or the capacity of the shaft rail assembly fasteners. In such cases, the loads should be kept below these practical limits, however, the full corresponding life capacity benefits are still realized.

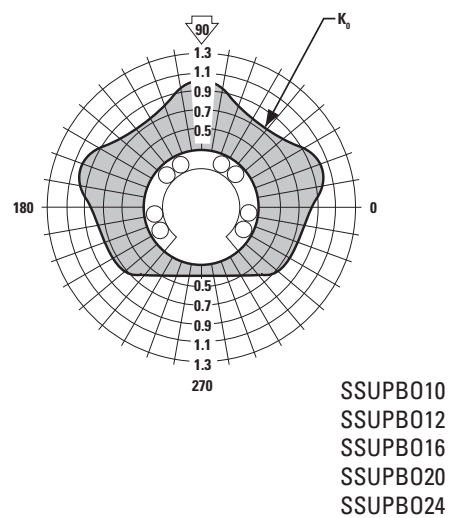
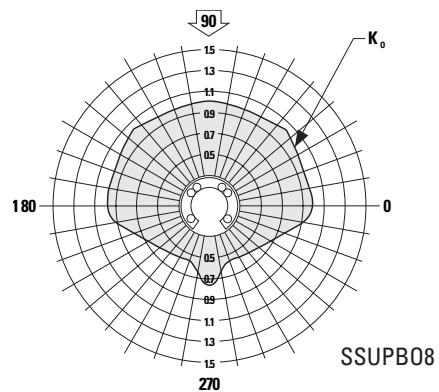

# Super Smart Ball Bushing Twin Pillow Blocks (Open Type) for Continuously Supported Applications

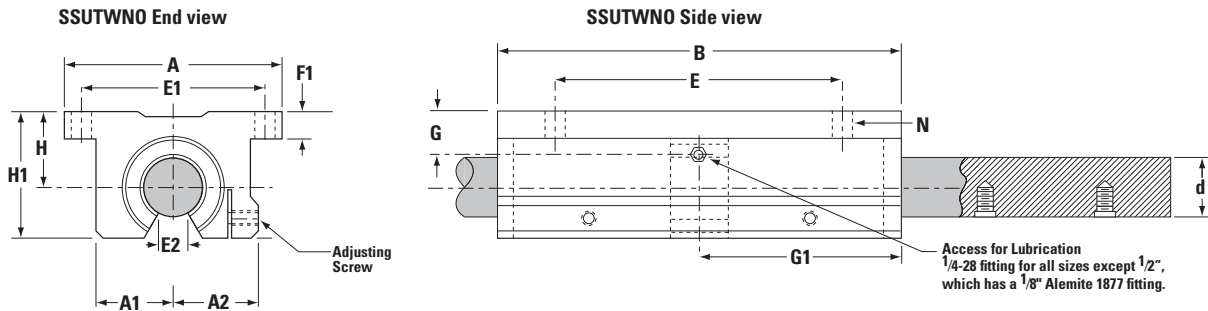
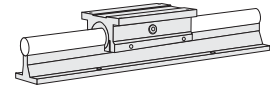

## Super Smart Ball Bushing Twin Pillow Blocks (Open Type, seal at both ends) and 60 Case® LinearRace® (Dimensions in inches)

Part Number <sup>(1)</sup>		Nominal Diameter	H ±.003	H1
Super Smart Ball Bushing Pillow Block	60 Case LinearRace*			
SSUTWNO8	1/2 L PD	.500	.687	1.13
SSUTWNO10	5/8 L PD	.625	.875	1.44
SSUTWNO12	3/4 L PD	.750	.937	1.56
SSUTWNO16	1 L PD	1.000	1.187	2.00
SSUTWNO20	1 1/4 L PD	1.250	1.500	2.50
SSUTWNO24	1 1/2 L PD	1.500	1.750	2.94

\* 60 Case begins on page 176.

Part Number <sup>(1)</sup> Super Smart Ball Bushing Pillow Block	A	A1	A2	B	E ±.010	E1 ±.010	E2 min.	F1	G	G1	N Hole	N1 Bolt	Pillow Block Mass lb	Dynamic <sup>(2)</sup> Load Capacity lb <sub>i</sub>
	SSUTWNO8	2.00	.69	.75	3.50	2.500	1.688	.31	.25	.56	1.75	.16		
SSUTWNO10	2.50	.88	.94	4.00	3.000	2.125	.34	.28	.67	2.00	.19	#8	.82	1240
SSUTWNO12	2.75	.94	1.00	4.50	3.500	2.375	.41	.31	.94	2.25	.19	#8	1.02	2260
SSUTWNO16	3.25	1.19	1.25	6.00	4.500	2.875	.53	.38	1.20	3.00	.22	#10	2.06	3800
SSUTWNO20	4.00	1.50	1.63	7.50	5.500	3.500	.62	.44	1.50	3.75	.22	#10	4.30	4700
SSUTWNO24	4.75	1.75	1.88	9.00	6.500	4.125	.74	.50	1.75	4.50	.28	.25	6.88	7760

(1) For part number description and specifications, see page 34.

(2) The Dynamic Load Capacity is based on a rated travel life of 2 million inches. The actual Dynamic Load Capacity can be affected by the orientation of the bearing or the direction of the applied load. For Dynamic Load Correction Factors, see following polar graphs. Dynamic load capacity is based on two bearings equally loaded.



## Load/Life Graph

(Lines indicate limiting load for given Ball Bushing® Bearing)

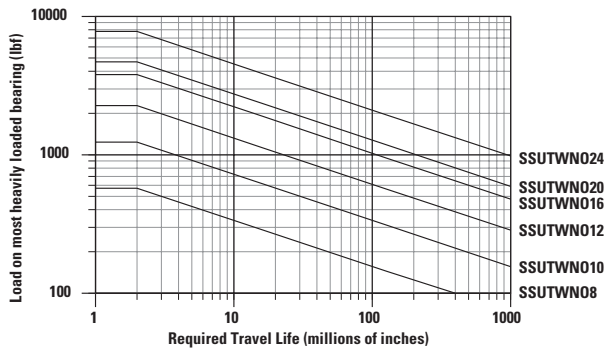

### Determining Ball Bushing Bearing Size

To determine the proper Ball Bushing Bearing size, enter the chart with the maximum load of the most heavily loaded bearing and the required travel life. Mark where the two lines intersect. All Ball Bushing Bearing sizes that pass through or above and to the right of this point may be suitable for this application.

**Note:** For the purpose of using this chart, load on most heavily loaded bearing = maximum applied load/ $K_0$ . Where  $K_0$  can be determined from the Polar Graph to the right.

## Polar Graphs

The actual dynamic load capacity of a Ball Bushing Bearing is determined by the orientation of the bearing or direction of the applied load. The load correction factor  $K_0$  is found by knowing the direction of the applied load relative to the orientation of the bearings ball tracks and referring to the polar graph. To determine the actual dynamic load capacity, multiply the proper correction factor by the dynamic load capacity listed in the product table on the previous page.

**Note:** For Super Smart Ball Bushing Bearings and other extremely high load bearings, the bearing load capacity as indicated by the polar charts may be practically limited by the degree of shaft flexure acceptable, or the capacity of the shaft rail assembly fasteners. In such cases, the loads should be kept below these practical limits, however, the full corresponding life capacity benefits are still realized.

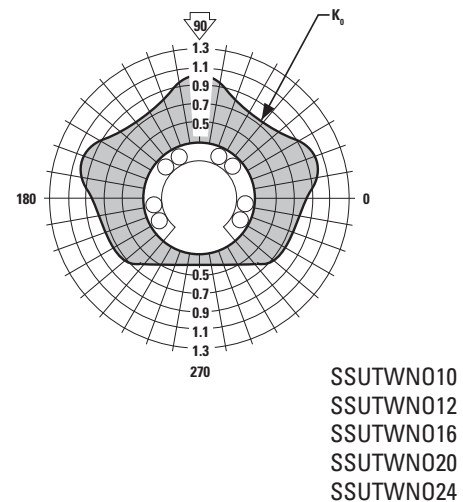
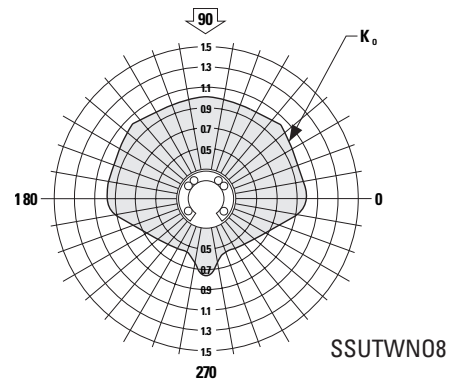

# Super Smart Ball Bushing Rigid Steel Pillow Blocks

(Open Type) for Continuously Supported Applications

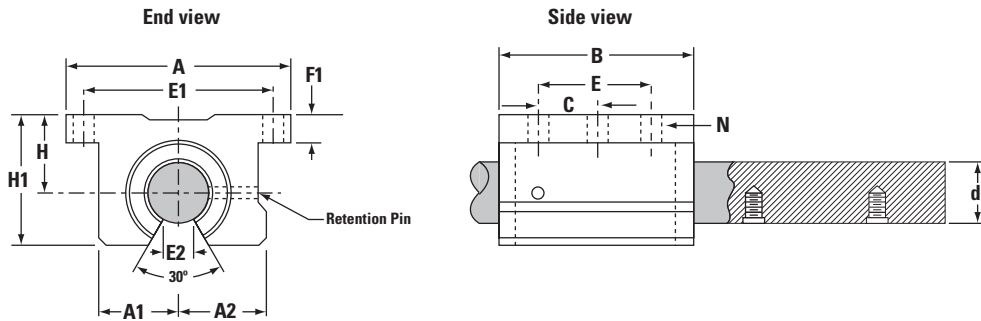
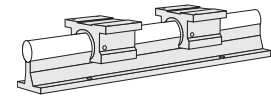

Rigid steel housing and high performance Super Smart Ball Bushing Bearing combine to reduce deflection and cost up to 66%.

## Super Smart Ball Bushing Bearing Rigid Steel Pillow Blocks (Open Type, seal at both ends) and LinearRace® (Dim. in in.)

Part Number <sup>(1)</sup>		Nominal Diameter	H ±.003	H1	A	A1	A2	B
Super Smart Ball Bushing Rigid Steel Pillow Block	60 Case LinearRace* Shaft							
SSURPB012	3/4 L PD	.750	.937	1.56	2.75	.94	1.00	1.88
SSURPB016	1 L PD	1.000	1.187	2.00	3.25	1.19	1.25	2.63
SSURPB024	1 1/2 L PD	1.500	1.750	2.94	4.75	1.75	1.88	3.75

\* 60 Case begins on page 176.

Part Number <sup>(1)</sup>	60 Case LinearRace Diameter d	E ±.010	C ±.010	E1 ±.010	E2 min.	F1	N		Pillow Block Mass lb	Dynamic <sup>(2)</sup> Load Capacity lb <sub>f</sub>
							Hole	Bolt		
SSURPB012	.7495/.7490	1.250	.625	2.375	.43	.31	.19	#8	1.10	1130
SSURPB016	.9995/.9990	1.750	.875	2.875	.56	.38	.22	#10	2.30	1900
SSURPB024	1.4994/1.4989	2.500	1.250	4.125	.81	.50	.28	.25	7.00	3880

(1) For part number description and specifications, see page 34.

(2) The Dynamic Load Capacity is based on a rated travel life of 2 million inches. The actual Dynamic Load Capacity can be affected by the orientation of the bearing or the direction of the applied load. For Dynamic Load Correction Factors, see following polar graphs.

### Super Smart Ball Bushing Rigid Steel Pillow Blocks provide:

- **Faster settling time... Greater Productivity**
- **Less deflection... Greater Accuracy**
- **Highest Load Capacity... Smallest Envelope**
- **Longest Bearing Life... Greater Reliability**



## Polar Graphs

The actual dynamic load capacity of a Ball Bushing® Bearing is determined by the orientation of the bearing or direction of the applied load. The load correction factor  $K_0$  is found by knowing the direction of the applied load relative to the orientation of the bearings ball tracks and referring to the polar graph. To determine the actual dynamic load capacity, multiply the proper correction factor by the dynamic load capacity listed in the product table on the previous page.

Note: For Super Smart Ball Bushing Bearings and other extremely high load bearings, the bearing load capacity as indicated by the polar charts may be practically limited by the degree of shaft flexure acceptable, or the capacity of the shaft rail assembly fasteners. In such cases, the loads should be kept below these practical limits, however, the full corresponding life capacity benefits are still realized.

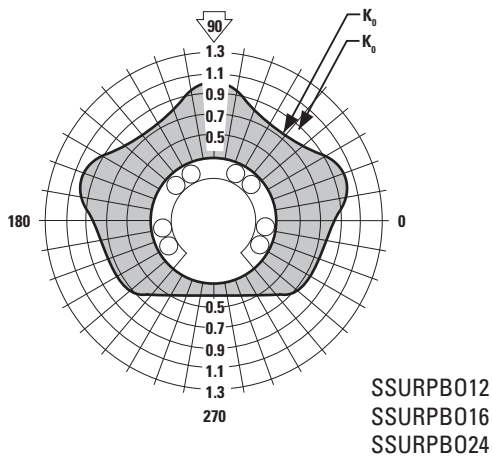

## Pick and Place X-Y System

### Objective

Build an X-Y System that transfers the work piece between two separate machining stations.

### Solution

Assemble the X-Y System utilizing Super Smart pillow blocks on end-supported 60 Case® LinearRace® for the X-axis and continuously supported 60 Case LinearRace on the Y-axis. Utilize Thomson ball screw assemblies for high-speed positioning.

### Benefits

The 60 Case LinearRace and 60 Case LinearRace end support blocks provide an important bridge between machining stations. The Super Smart Ball Bushing pillow blocks and Thomson ball screws provide uninterrupted high-speed movement of the work piece. Productivity increases by 200%.

### Products Specified

#### X-axis

- 2 - 1 1/2 L CTL x 48.00 in (60 Case LinearRace)
- 4 - SB24 (60 Case LinearRace End Support Blocks)
- 4 - SSUPB24 (Super Smart Ball Bushing Pillow Blocks)
- 1 - 1 1/4 x .200 (Thomson Ball Screw Assembly)

#### Y-axis

- 2 - LSR-20-PD x 48.00 in (Low-profile 60 Case LinearRace Support Rail)
- 4 - SSUPB020 (Super Smart Ball Bushing Pillow Blocks)
- 1 - 1 1/4 x .200 (Thomson Ball Screw Assembly)
- 2 - 1 1/4 L PD CTL x 48.00 in (60 Case LinearRace)

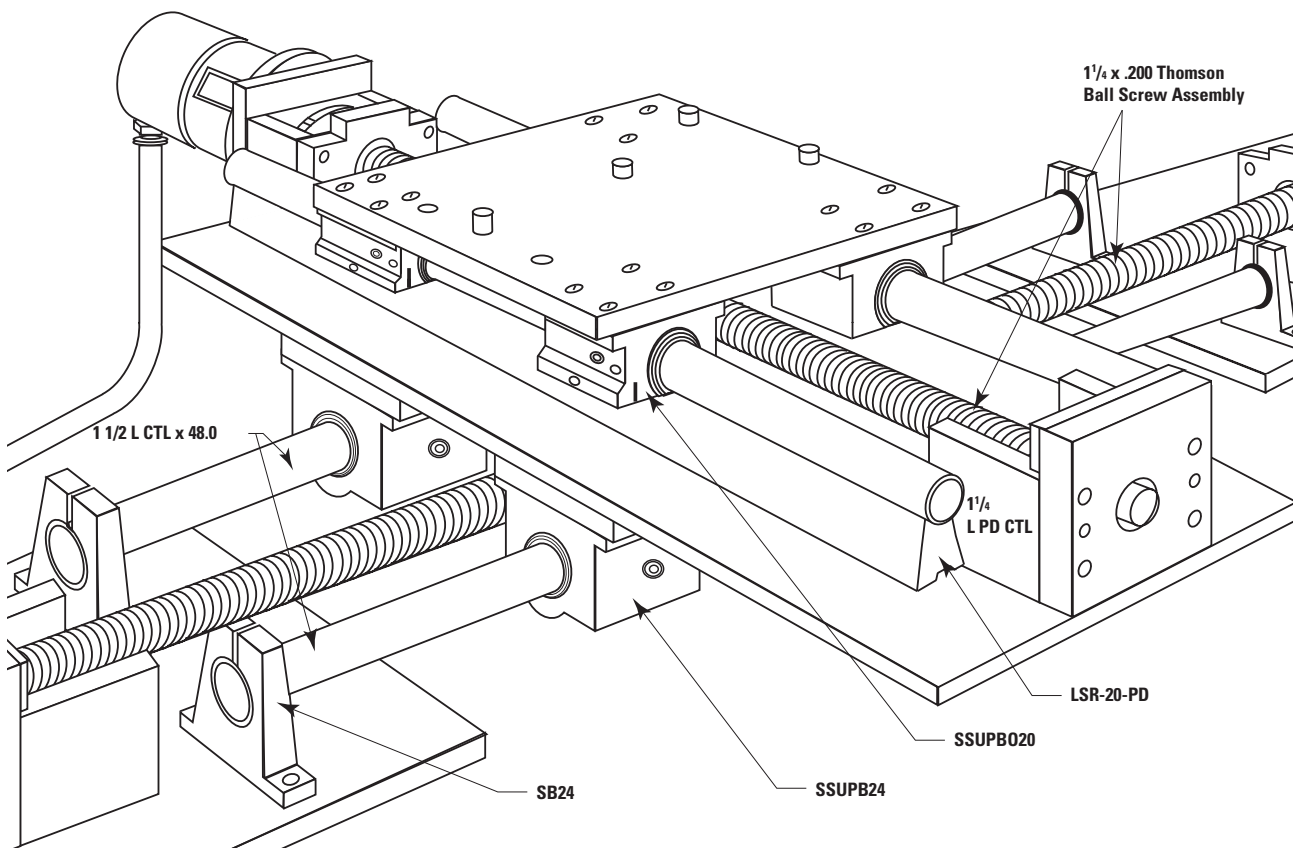



## Super Ball Bushing® Bearing Products

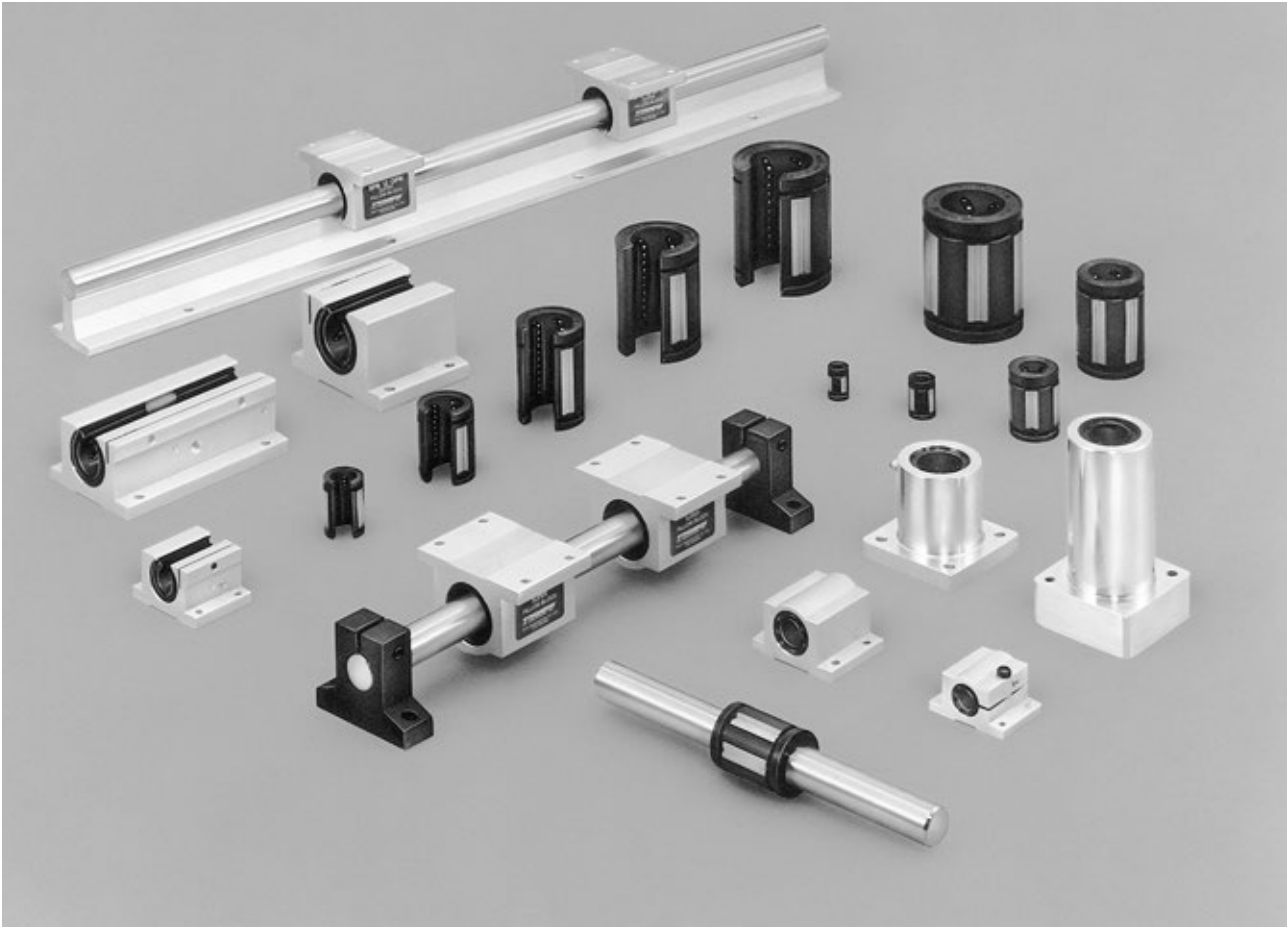

### Thomson Super Ball Bushing Bearing products offer:

- A self-aligning capability up to  $.5^\circ$  compensating for inaccuracies in base flatness or carriage machining.
- The RoundRail Advantage combined with the self-aligning feature, eliminating the need for derating factors commonly required for linear guides.
- Travel speeds up to 10 ft./s without a reduction in load capacity.
- Lightweight, wear-resistant, engineered-polymer retainers and outer sleeves that reduce inertia and noise.
- Radially floating bearing plates. When installed in an adjustable housing, the Super Ball Bushing Bearing may be adjusted to a specific diametrical fit-up for accurate and repeatable movement.
- A constant coefficient of friction as low as .001.
- The use of smaller, less expensive drive motors, belts, linkages, gears and ball screws, when replacing high-friction plain bearings.
- A closed configuration for end-supported applications and an open configuration for continuously supported applications.
- Ready-to-install pillow blocks with double-acting seals and an access for lubrication. Installation and downtime is minimized.

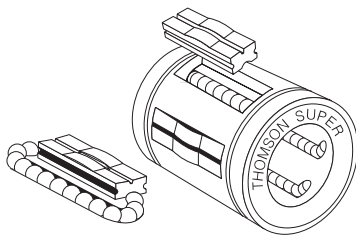

Figure 1

The Super Ball Bushing Bearing has been the industry standard for self-aligning linear bearings for more than 20 years. This bearing provides three times the load capacity or 27 times the travel life of conventional linear bearings. This dramatic improvement in bearing performance significantly reduces downtime and maintenance, while increasing machine reliability. Thomson invented the Super Ball Bushing Bearing with many unique design features. Besides the dramatic increase in load capacity, the Super Ball Bushing Bearing is self-aligning, lightweight and adjustable with a low coefficient of friction (Figure 1).

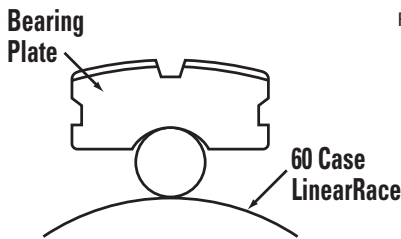

Figure 2

### Three Times the Load Capacity

The bearing plates are hardened, bearing quality steel with ball-conforming grooves (Figure 2). The groove is slightly larger than the ball diameter, providing an optimal area for ball contact. The greater ball-to-bearing plate contact provides the increase in load capacity or travel life.

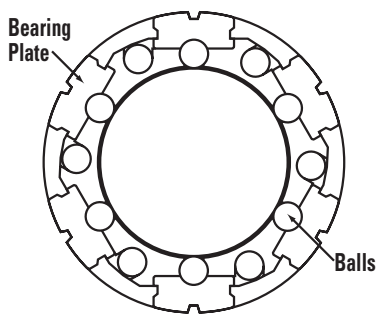

Figure 3

Cross-section of Super Ball Bushing Bearing

### Zero Clearance Fit

The bearing plates are also designed to float radially (Figure 3). When the bearing is mounted in an adjustable housing, selected fit-ups can be achieved on the 60 Case<sup>®</sup> LinearRace<sup>®</sup> (shaft).

### Self-Aligning

The Super Ball Bushing Bearing plates pivot .5° about their centers (Figure 4) to assure smooth entry and exit of the precision bearing balls. Each plate aligns itself automatically to compensate for inaccurate housing bore alignment, base flatness or carriage machining. This provides uniform ball loading, smooth ball recirculation and a constant coefficient of friction.

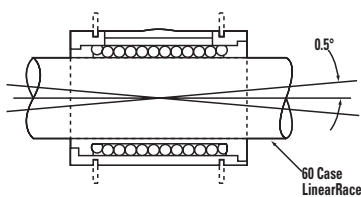

Figure 4

### Smooth, Quiet Operation

The Super Ball Bushing Bearing's outer sleeve and retainer are made of wear-resistant, low-friction engineering polymer. It reduces inertia and operating noise levels significantly.



# Part Number Description and Specification

## Super Ball Bushing® Bearings (Closed Type) for End-Supported Applications

### SUPER16-DDCR

Type	Description	Size	Nominal Diameter	Seals Options	Ball Options	Lube Options	Other Options
SUPER	Super Ball Bushing bearings	3	.188	Blank No Seals DD Integral Seals	Option Description	DP Dry Pack LL Lubricated with Thomson Linear Lube	RP Roll Pack (no box)
SCB	Super Ball Bushing Cartridge bearings	4	.250		CR Corrosion Resistant		
		6	.375		NB Nylon Balls		
		8	.500		NBA Alternating Nylon Balls		
		10	.625				
		12	.750				
		16	1.000				
		20	1.250				
		24	1.500				
		32	2.000				

## Super Ball Bushing Pillow Blocks (Closed Type) for End Supported Applications

### SPB16ADJ-CR

Type	Description	Size	Nominal Diameter	Ball Options	Lube Options
SPB	Super Ball Bushing Pillow Blocks	4	.250	Option Description	DP Dry Pack LL Lubricated with Thomson Linear Lube L4L Lube for Life
TWN	Super Ball Bushing Twin Pillow Blocks	6	.375	CR Corrosion Resistant	
		8	.500	NB Nylon Balls	
		10	.625	NBA Alternating Nylon Balls	
		12	.750		
		16	1.000		
		20	1.250		
		24	1.500		
		32	2.000		

Type	Description
-	Closed Type, Non-Adjustable
ADJ	Closed Type, Adjustable Pillow Block

Not all options are available in all sizes.  
 See catalog pages or contact Thomson Customer Support for combination availability.  
 For additional information on bearing options, see page 267.

# Super Ball Bushing Bearings (Closed Type) for End-Supported Applications

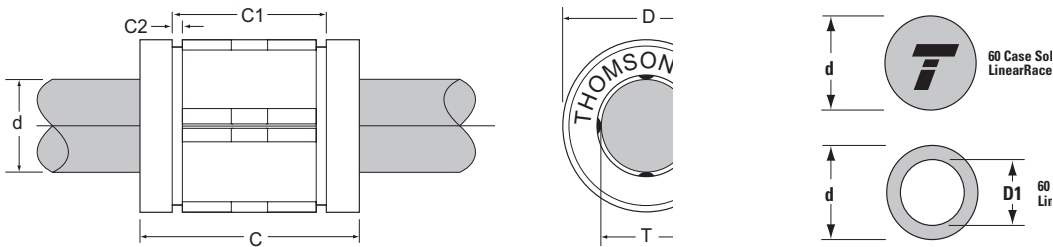
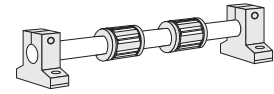

**Super Ball Bushing Bearings (Closed Type) and 60 Case® LinearRace®** (Dimensions in inches)

Part Number <sup>(1)</sup>		Nominal Diameter	Length C	Distance Between Retaining Ring Grooves C1	Retaining Ring Groove min. C2	Number of Ball Circuits	Ball Bushing Bearing Mass lb	60 Case LinearRace Minimum Depth of Hardness	60 Case Solid LinearRace Mass lb/in	60 Case Tubular Lite LinearRace Mass lb/in	60 Case Tubular Lite LinearRace ID D1
Ball Bushing Bearing	60 Case Linear Race										
SUPER3	3/16 L	.188	.562/.547	–	–	4	.003	.027	.008	–	–
SUPER4	1/4 L	.250	.750/.735	.511/.501	.039	4	.01	.027	.01	–	–
SUPER6	3/8 L	.375	.875/.860	.699/.689	.039	4	.02	.027	.03	–	–
SUPER8	1/2 L	.500	1.250/1.230	1.032/1.012	.050	4	.04	.04	.06	–	–
SUPER10	5/8 L	.625	1.500/1.480	1.105/1.095	.056	5	.10	.04	.09	–	–
SUPER12	3/4 L	.750	1.625/1.605	1.270/1.250	.056	6	.14	.06	.13	.08	.46/.41
SUPER16	1 L	1.000	2.250/2.230	1.884/1.864	.070	6	.25	.08	.22	.16	.62/.56
SUPER20	1 1/4 L	1.250	2.625/2.600	2.004/1.984	.068	6	.45	.08	.35	–	–
SUPER24	1 1/2 L	1.500	3.000/2.970	2.410/2.390	.086	6	.85	.08	.50	.33	.93/.84
SUPER32	2 L	2.000	4.000/3.960	3.193/3.163	.105	6	1.45	.10	.89	.54	1.31/1.18

Part Number <sup>(1)</sup>	Working Bore Diameter T	Recommended Housing Bore		60 Case LinearRace Diameter d	Ball Bushing Bearing/LinearRace Fit Up ‡		Dynamic <sup>(2)</sup> Load Capacity lb <sub>r</sub>
		Fixed D	Adjustable D		Fixed Diameter Housing	Adjustable Diameter Housing (Before Adjustment)	
SUPER3	.1875/.1870	.3755/.3750	.3760/.3750	.1870/.1865	.0015C/.0000	.002C/.0000	35
SUPER4	.2500/.2495	.5005/.5000	.5010/.5000	.2495/.2490	.0015C/.0000	.002C/.0000	60
SUPER6	.3750/.3745	.6255/.6250	.6260/.6250	.3745/.3740	.0015C/.0000	.002C/.0000	100
SUPER8	.5000/.4995	.8755/.8750	.8760/.8750	.4995/.4990	.0015C/.0000	.002C/.0000	255
SUPER10	.6250/.6245	1.1255/1.1250	1.1260/1.1250	.6245/.6240	.0015C/.0000	.002C/.0000	450
SUPER12	.7500/.7495	1.2505/1.2500	1.2510/1.2500	.7495/.7490	.0015C/.0000	.002C/.0000	600
SUPER16	1.0000/.9995	1.5630/1.5625	1.5635/1.5625	.9995/.9990	.0015C/.0000	.002C/.0000	1050
SUPER20	1.2500/1.2494	2.0008/2.0000	2.0010/2.0000	1.2495/1.2490	.0018C/.0001P	.002C/.0001P	1500
SUPER24	1.5000/1.4994	2.3760/2.3750	2.3760/2.3750	1.4994/1.4989	.0021C/.0000	.0021C/.0000	2000
SUPER32	2.0000/1.9992	3.0010/3.0000	3.0010/3.0000	1.9994/1.9987	.0023C/.0002P	.0023C/.0002P	3000

‡ P = Preload, C = Clearance

(1) For part number description and specifications, see page 46.

(2) The Dynamic Load Capacity is based on a rated travel life of 2 million inches. The actual Dynamic Load Capacity can be affected by the orientation of the bearing or the direction of the applied load. For Dynamic Load Correction Factors, see following polar graphs.

Note: For additional technical information, see the Engineering section beginning on page 256.



## Load/Life Graph

(Lines indicate limiting load for given Ball Bushing® Bearing)

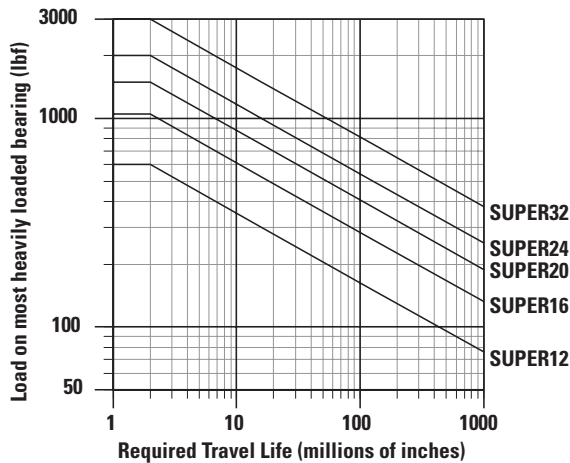
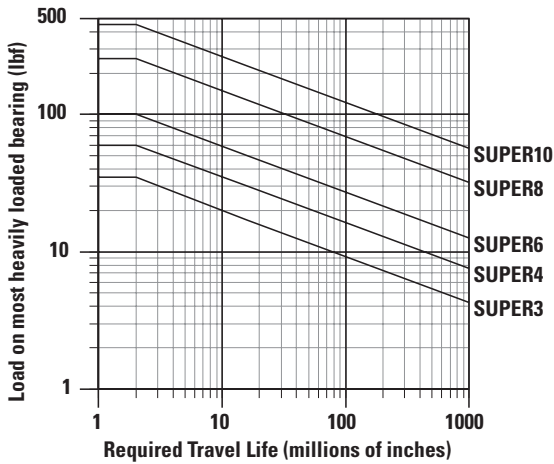

### Determining Ball Bushing Bearing Size

To determine the proper Ball Bushing Bearing size, enter the chart with the maximum load of the most heavily loaded bearing and the required travel life. Mark where the two lines intersect. All Ball Bushing Bearing sizes that pass through or above and to the right of this point may be suitable for this application.

**Note:** For the purpose of using this chart, load on most heavily loaded bearing = maximum applied load/ $K_0$ . Where  $K_0$  can be determined from the Polar Graph to the right.

## Polar Graphs

The actual dynamic load capacity of a Ball Bushing Bearing is determined by the orientation of the bearing or direction of the applied load. The load correction factor  $K_0$  is found by knowing the direction of the applied load relative to the orientation of the bearings ball tracks and referring to the polar graph. To determine the actual dynamic load capacity, multiply the proper correction factor by the dynamic load capacity listed in the product table on the previous page.

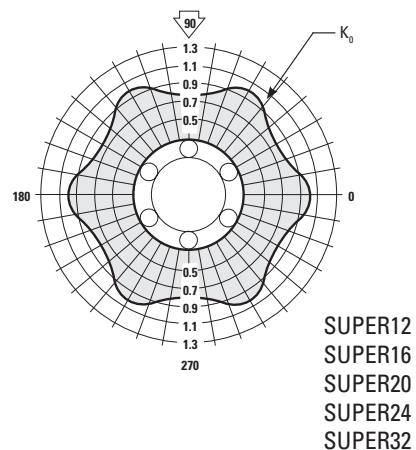
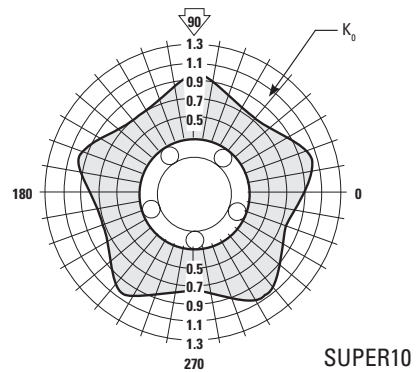
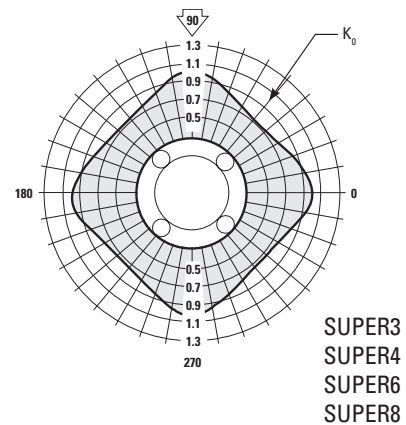

# Sealed Super Ball Bushing Bearings (Closed Type) for End-Supported Applications

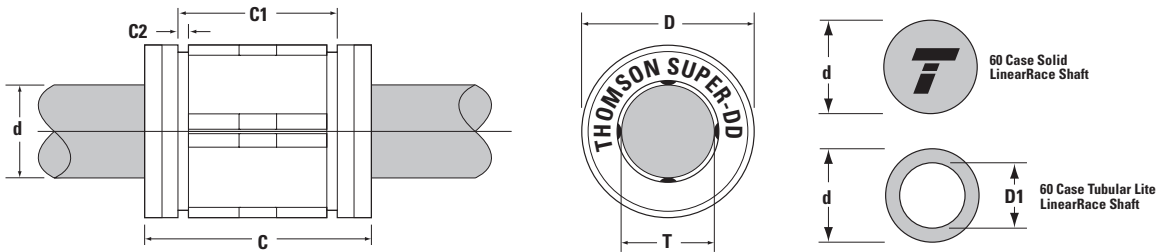
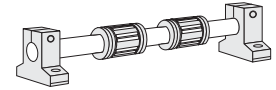

**Sealed Super Ball Bushing Bearings (Closed Type, seal at both ends) and 60 Case® LinearRace®** (Dimensions in inches)

Part Number <sup>(1)</sup>		Nominal Diameter	Length C	Distance Between Retaining Ring Grooves C1	Retaining Ring Groove min. C2	Number of Ball Circuits	Ball Bushing Bearing Mass lb	60 Case LinearRace Minimum Depth of Hardness	60 Case Solid LinearRace Mass lb/in	60 Case Tubular Lite LinearRace Mass lb/in	60 Case Tubular Lite LinearRace ID D1
Ball Bushing Bearing	60 Case Linear Race										
SUPER8-DD	1/2 L	.500	1.500/1.460	1.032/1.012	.050	4	.05	.04	.06	–	–
SUPER10-DD	5/8 L	.625	1.750/1.710	1.105/1.095	.056	5	.11	.04	.09	–	–
SUPER12-DD	3/4 L	.750	1.875/1.835	1.270/1.250	.056	6	.15	.06	.13	.08	.46/.41
SUPER16-DD	1 L	1.000	2.625/2.585	1.884/1.864	.070	6	.27	.08	.22	.16	.62/.56

Part Number <sup>(1)</sup>	Working Bore Diameter T	Recommended Housing Bore Dia.		60 Case LinearRace Diameter d	Ball Bushing Bearing/LinearRace Fit Up ‡		Dynamic <sup>(2)</sup> Load Capacity lb <sub>r</sub>
		Fixed D	Adjustable D		Fixed Diameter Housing	Adjustable Diameter Housing (Before Adjustment)	
SUPER8-DD	.5000/.4995	.8750/.8755	.8750/.8760	.4995/.4990	.0015C/.0000	.002C/.0000	255
SUPER10-DD	.6250/.6245	1.1250/1.1255	1.1250/1.1260	.6245/.6240	.0015C/.0000	.002C/.0000	450
SUPER12-DD	.7500/.7495	1.2500/1.2505	1.2500/1.2510	.7495/.7490	.0015C/.0000	.002C/.0000	600
SUPER16-DD	1.0000/.9995	1.5625/1.5630	1.5625/1.5635	.9995/.9990	.0015C/.0000	.002C/.0000	1050

‡ P = Preload, C = Clearance

(1) For part number description and specifications, see page 46.

(2) The Dynamic Load Capacity is based on a rated travel life of 2 million inches. The actual Dynamic Load Capacity can be affected by the orientation of the bearing or the direction of the applied load. For Dynamic Load Correction Factors, see following polar graphs.

Note: For additional technical information, see the Engineering section beginning on page 256.



## Load/Life Graph

(Lines indicate limiting load for given Ball Bushing® Bearing)

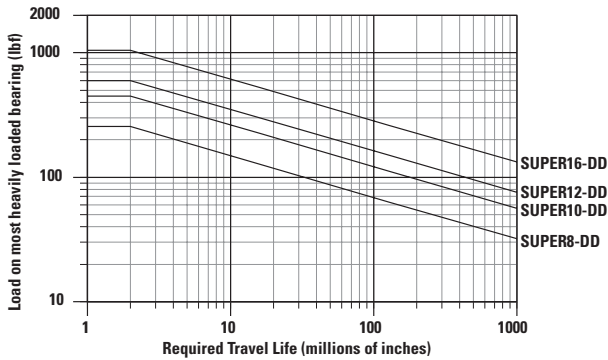

### Determining Ball Bushing Bearing Size

To determine the proper Ball Bushing Bearing size, enter the chart with the maximum load of the most heavily loaded bearing and the required travel life. Mark where the two lines intersect. All Ball Bushing Bearing sizes that pass through or above and to the right of this point may be suitable for this application.

**Note:** For the purpose of using this chart, load on most heavily loaded bearing = maximum applied load/ $K_0$ . Where  $K_0$  can be determined from the Polar Graph to the right.

## Polar Graphs

The actual dynamic load capacity of a Ball Bushing Bearing is determined by the orientation of the bearing or direction of the applied load. The load correction factor  $K_0$  is found by knowing the direction of the applied load relative to the orientation of the bearings ball tracks and referring to the polar graph. To determine the actual dynamic load capacity, multiply the proper correction factor by the dynamic load capacity listed in the product table on the previous page.

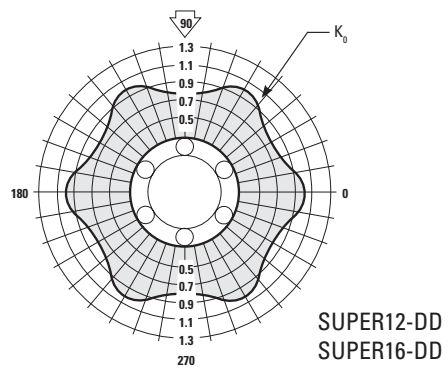
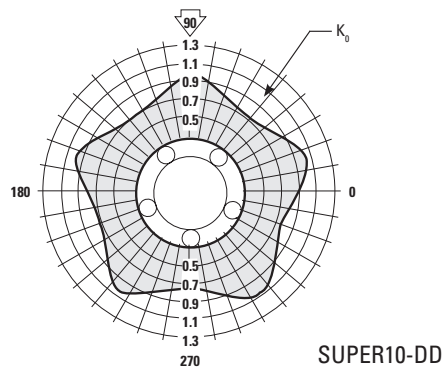
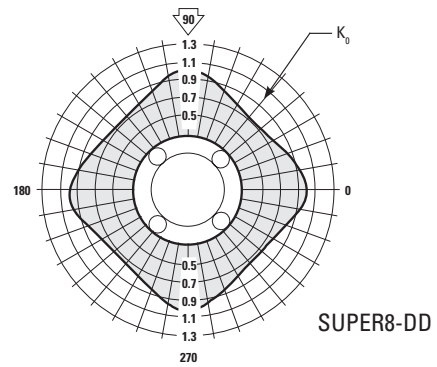

# Super Ball Bushing Cartridge Bearings (Closed Type) for End-Supported Applications

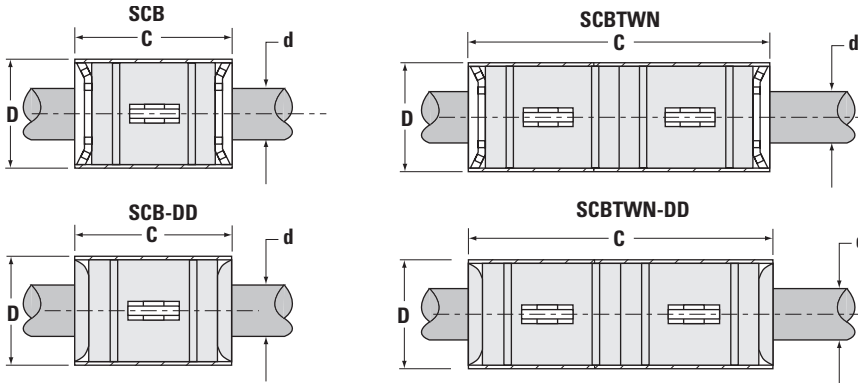
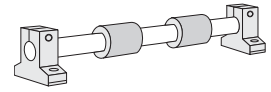

**Super Ball Bushing Cartridge Bearings and 60 Case® LinearRace®** (Dimensions in inches)

Part Number <sup>(1)</sup>			Nominal Diameter	Length C ±.005	Number of Ball Circuits	Ball Bushing Mass w/out Seals lb	Ball Bushing Mass with Seals lb	60 Case LinearRace Diameter d	Nominal Outside Diameter D	Rec. Housing Bore Dia. Fixed	60 Case LinearRace Minimum Depth of Hardness	60 Case Solid LinearRace Mass lb/in	Dynamic <sup>(2)</sup> Load Capacity lb <sub>i</sub>
Without Seals	With Seals	60 Case Linear Race											
SCB4	SCB4-DD	1/4 L	.250	1.000	4	.01	.02	.2495/.2490	.531/.529	.535/.533	.027	.01	60
SCB6	SCB6-DD	3/8 L	.375	1.125	4	.02	.03	.3745/.3740	.656/.654	.660/.658	.027	.03	100
SCB8	SCB8-DD	1/2 L	.500	1.500	4	.06	.07	.4995/.4990	.906/.904	.910/.908	.04	.06	255

**Super Ball Bushing Twin Cartridge Bearings and 60 Case LinearRace** (Dimensions in inches)

Part Number <sup>(1)</sup>			Nominal Diameter	Length C ±.005	Number of Ball Circuits	Ball Bushing Mass w/out Seals lb	Ball Bushing Mass with Seals lb	60 Case LinearRace Diameter d	Nominal Outside Diameter D	Rec. Housing Bore Dia. Fixed	60 Case LinearRace Minimum Depth of Hardness	60 Case LinearRace Mass lb/in	Dynamic <sup>(2)</sup> Load Capacity lb <sub>i</sub>
Without Seals	With Seals	60 Case Linear Race											
SCB4TWN	SCB4TWN-DD	1/4 L	.250	1.750	4	.02	.04	.2495/.2490	.531/.529	.535/.533	.027	.01	120
SCB6TWN	SCB6TWN-DD	3/8 L	.375	2.000	4	.03	.04	.3745/.3740	.656/.654	.660/.658	.027	.03	200
SCB8TWN	SCB8TWN-DD	1/2 L	.500	2.750	4	.12	.13	.4995/.4990	.906/.904	.910/.908	.04	.06	510

(1) For part number description and specifications, see page 46.

(2) The Dynamic Load Capacity is based on a rated travel life of 2 million inches. The actual Dynamic Load Capacity can be affected by the orientation of the bearing or the direction of the applied load. For Dynamic Load Correction Factors, see following polar graphs. Dynamic load capacity for Twin configuration is based on two bearings equally loaded.

Note: For additional technical information, see the Engineering section beginning on page 256.



## Load/Life Graph

(Lines indicate limiting load for given Ball Bushing® Cartridge Bearing)

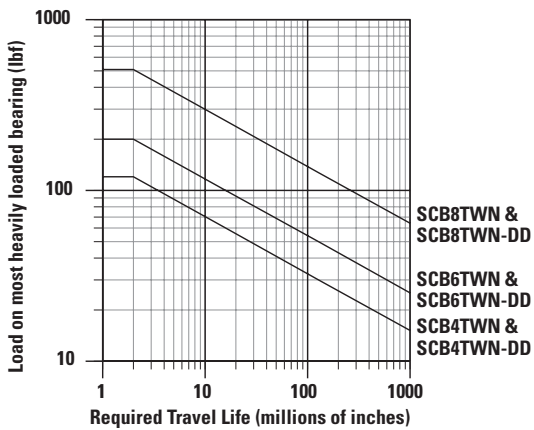
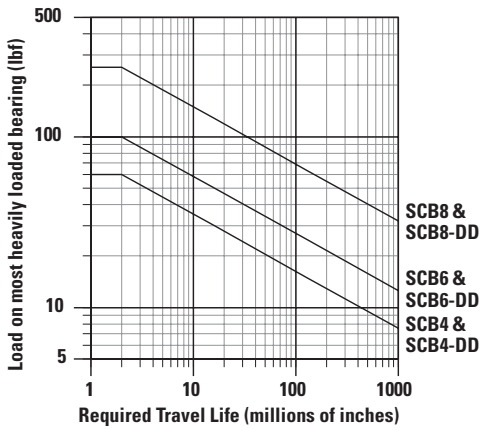

## Polar Graphs

The actual dynamic load capacity of a Ball Bushing Bearing is determined by the orientation of the bearing or direction of the applied load. The load correction factor  $K_0$  is found by knowing the direction of the applied load relative to the orientation of the bearings ball tracks and referring to the polar graph. To determine the actual dynamic load capacity, multiply the proper correction factor by the dynamic load capacity listed in the product table on the previous page.

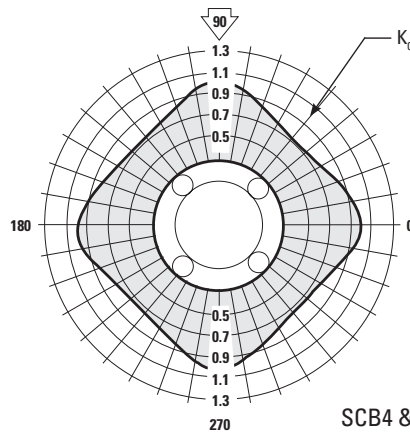

SCB4 & SCB4-DD  
 SCB6 & SCB6-DD  
 SCB8 & SCB8-DD  
 SCB4TWN & SCB4TWN-DD  
 SCB6TWN & SCB6TWN-DD  
 SCB8TWN & SCB8TWN-DD

### Determining Ball Bushing Bearing Size

To determine the proper Ball Bushing Bearing size enter the chart with the maximum load of the most heavily loaded bearing and the required travel life. Mark where the two lines intersect. All Ball Bushing Bearing sizes that pass through or above and to the right of this point may be suitable for this application.

**Note:** For the purpose of using this chart, load on most heavily loaded bearing = maximum applied load/ $K_0$ . Where  $K_0$  can be determined from the Polar Graph to the right.

# Super Ball Bushing Pillow Blocks (Closed and Adjustable Type) for End-Supported Applications

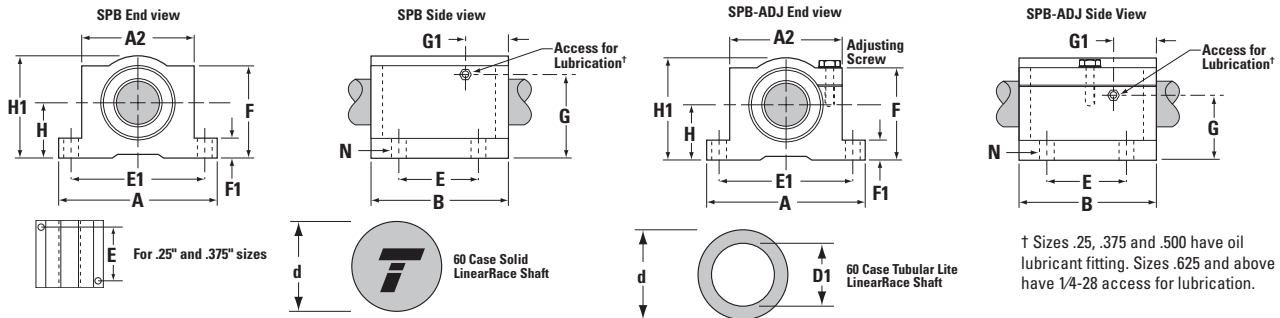
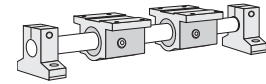

## Super Ball Bushing Pillow Blocks (Closed and Adjustable Types, seal at both ends) and 60 Case® LinearRace® (Dim. in in.)

Part Number <sup>(1)</sup>		60 Case LinearRace	Nominal Diameter	H ±.003	H1	60 Case LinearRace Diameter d	60 Case LinearRace Minimum Depth of Hardness	60 Case Solid LinearRace Mass lb/in	60 Case Tubular Lite LinearRace Mass lb/in	60 Case Tubular Lite LinearRace ID D1
Fixed	Adjustable									
SPB4	SPB4ADJ	1/4 L	.250	.437	.81	.2495/.2490	.027	.01	—	—
SPB6	SPB6ADJ	3/8 L	.375	.500	.94	.3745/.3740	.027	.03	—	—
SPB8	SPB8ADJ	1/2 L	.500	.687	1.25	.4995/.4990	.04	.06	—	—
SPB10	SPB10ADJ	5/8 L	.625	.875	1.63	.6245/.6240	.04	.09	—	—
SPB12	SPB12ADJ	3/4 L	.750	.937	1.75	.7495/.7490	.06	.13	.08	.46/.41
SPB16	SPB16ADJ	1 L	1.000	1.187	2.19	.9995/.9990	.08	.22	.16	.62/.56
SPB20	SPB20ADJ	1 1/4 L	1.250	1.500	2.81	1.2495/1.2490	.08	.35	—	—
SPB24	SPB24ADJ	1 1/2 L	1.500	1.750	3.25	1.4994/1.4989	.08	.50	.33	.93/.84
SPB32	SPB32ADJ	2 L	2.000	2.125	4.06	1.9994/1.9987	.10	.89	.54	1.31/1.18

Part Number <sup>(1)</sup>		A	A2	B	E ±.010	E1 ±.010	F	F1	G	G1	N		Pillow Block Mass lb	Dynamic Load Capacity lb <sub>f</sub>
Fixed	Adjustable										Hole	Bolt		
SPB4	SPB4ADJ	1.63	1.00	1.19	.750	1.313	.75	.19	.60	.41	.16	#6	.10	60
SPB6	SPB6ADJ	1.75	1.13	1.31	.875	1.438	.88	.19	.70	.41	.16	#6	.13	100
SPB8	SPB8ADJ	2.00	1.38	1.69	1.000	1.688	1.13	.25	.97	.44	.16	#6	.20	255
SPB10	SPB10ADJ	2.50	1.75	1.94	1.125	2.125	1.44	.28	1.20	.69	.19	#8	.50	450
SPB12	SPB12ADJ	2.75	1.88	2.06	1.250	2.375	1.56	.31	.94	.78	.19	#8	.60	600
SPB16	SPB16ADJ	3.25	2.38	2.81	1.750	2.875	1.94	.38	1.19	.91	.22	#10	1.20	1050
SPB20	SPB20ADJ	4.00	3.00	3.63	2.000	3.500	2.50	.44	1.50	1.37	.22	#10	2.50	1500
SPB24	SPB24ADJ	4.75	3.50	4.00	2.500	4.125	2.88	.50	1.75	1.13	.28	1/4	3.80	2000
SPB32	SPB32ADJ	6.00	4.50	5.00	3.250	5.250	3.63	.63	1.30	1.25	.41	3/8	7.00	3000

(1) For part number description and specifications, see page 46.

(2) The Dynamic Load Capacity is based on a rated travel life of 2 million inches. The actual Dynamic Load Capacity can be affected by the orientation of the bearing or the direction of the applied load. For Dynamic Load Correction Factors, see following polar graphs.

Note: For additional technical information, see the Engineering section beginning on page 256.



## Load/Life Graph

(Lines indicate limiting load for given Ball Bushing® Pillow Block)

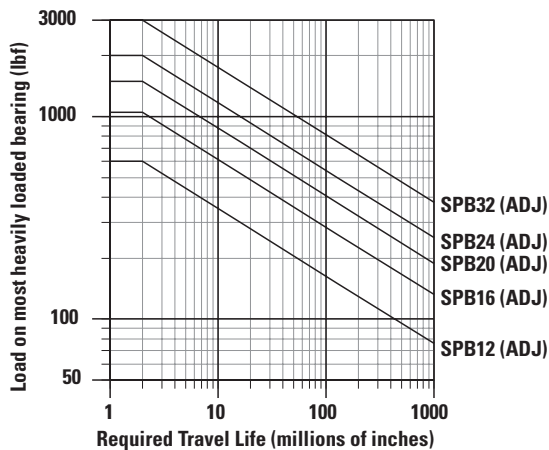
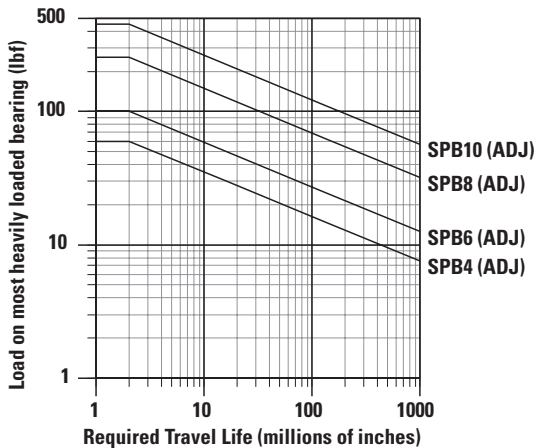

### Determining Ball Bushing Bearing Size

To determine the proper Ball Bushing Bearing size, enter the chart with the maximum load of the most heavily loaded bearing and the required travel life. Mark where the two lines intersect. All Ball Bushing Bearing sizes that pass through or above and to the right of this point may be suitable for this application.

**Note:** For the purpose of using this chart, load on most heavily loaded bearing = maximum applied load/ $K_0$ . Where  $K_0$  can be determined from the Polar Graph to the right.

## Polar Graphs

The actual dynamic load capacity of a Ball Bushing Bearing is determined by the orientation of the bearing or direction of the applied load. The load correction factor  $K_0$  is found by knowing the direction of the applied load relative to the orientation of the bearings ball tracks and referring to the polar graph. To determine the actual dynamic load capacity, multiply the proper correction factor by the dynamic load capacity listed in the product table on the previous page.

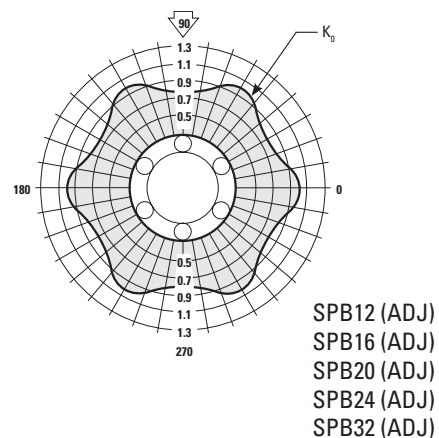
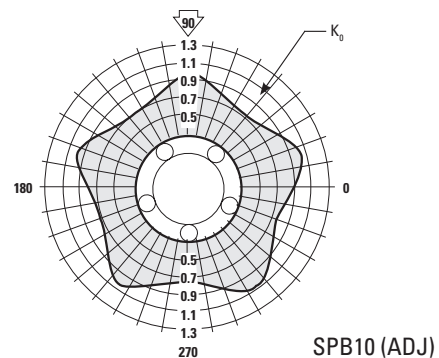
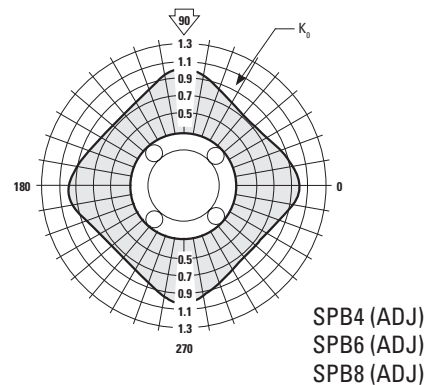

# Super Ball Bushing Twin Pillow Blocks (Closed Type) for End-Supported Applications

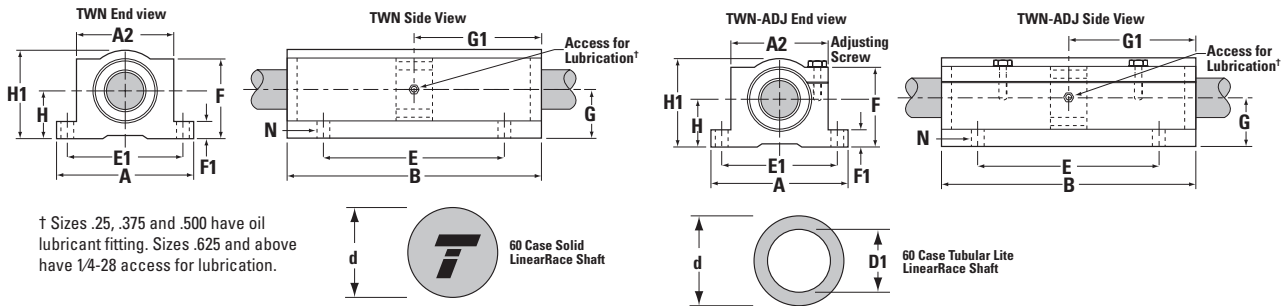
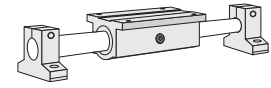

## Super Ball Bushing Twin Pillow Blocks (Closed and Adjustable Type, seal at both ends) and LinearRace® (Dim. in in.)

Part Number <sup>(1)</sup>		60 Case LinearRace	Nominal Diameter	H ±.003	H1	60 Case LinearRace Diameter d	60 Case LinearRace Minimum Depth of Hardness	60 Case Solid LinearRace Mass lb/in	60 Case Tubular Lite LinearRace Mass lb/in	60 Case Tubular Lite LinearRace ID D1
Fixed	Adjustable									
TWN4	TWN4ADJ	1/4 L	.250	.437	.81	.2495/.2490	.027	.01	—	—
TWN6	TWN6ADJ	3/8 L	.375	.500	.94	.3745/.3740	.027	.03	—	—
TWN8	TWN8ADJ	1/2 L	.500	.687	1.25	.4995/.4990	.04	.06	—	—
TWN10	TWN10ADJ	5/8 L	.625	.875	1.63	.6245/.6240	.04	.09	—	—
TWN12	TWN12ADJ	3/4 L	.750	.937	1.75	.7495/.7490	.06	.13	.08	.46/.41
TWN16	TWN16ADJ	1 L	1.000	1.187	2.19	.9995/.9990	.08	.22	.16	.62/.56
TWN20	TWN20ADJ	1 1/4 L	1.250	1.500	2.81	1.2495/1.2490	.08	.35	—	—
TWN24	TWN24ADJ	1 1/2 L	1.500	1.750	3.25	1.4994/1.4989	.08	.50	.33	.93/.84

Part Number <sup>(1)</sup>		A	A2	B	E ±.010	E1 ±.010	F	F1	G	G1	N		Pillow Block Mass lb	Dynamic <sup>(2)</sup> Load Capacity lb <sub>t</sub>
Fixed	Adjustable										Hole	Bolt		
TWN4	TWN4ADJ	1.63	1.00	2.50	2.000	1.313	.75	.19	.44	1.25	.16	#6	.19	120
TWN6	TWN6ADJ	1.75	1.13	2.75	2.250	1.438	.88	.19	.50	1.37	.16	#6	.25	200
TWN8	TWN8ADJ	2.00	1.38	3.50	2.500	1.688	1.13	.25	.59	1.75	.16	#6	.40	510
TWN10	TWN10ADJ	2.50	1.75	4.00	3.000	2.125	1.44	.28	.85	2.00	.19	#8	1.00	900
TWN12	TWN12ADJ	2.75	1.88	4.50	3.500	2.375	1.56	.31	.94	2.25	.19	#8	1.20	1200
TWN16	TWN16ADJ	3.25	2.38	6.00	4.500	2.875	1.94	.38	1.19	3.00	.22	#10	2.40	2100
TWN20	TWN20ADJ	4.00	3.00	7.50	5.500	3.500	2.50	.44	1.50	3.75	.22	#10	5.00	3000
TWN24	TWN24ADJ	4.75	3.50	9.00	6.500	4.125	2.88	.50	1.75	4.50	.28	1/4	7.80	4000

(1) For part number description and specifications, see page 46.

(2) The Dynamic Load Capacity is based on a rated travel life of 2 million inches. The actual Dynamic Load Capacity can be affected by the orientation of the bearing or the direction of the applied load. For Dynamic Load Correction Factors, see following polar graphs. Dynamic load capacity is based on two bearings equally loaded.

Note: For additional technical information, see the Engineering section beginning on page 256.



## Load/Life Graph

(Lines indicate limiting load for given Ball Bushing® Pillow Block)

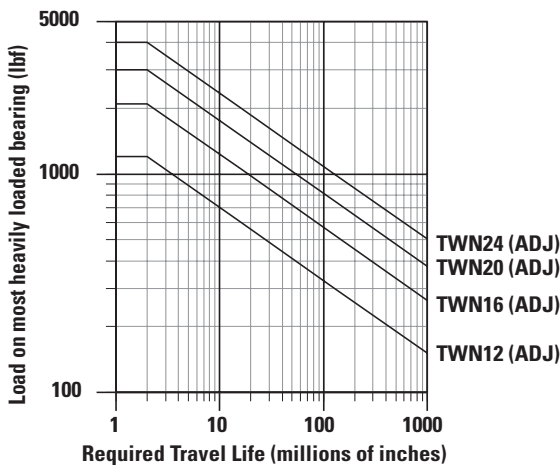
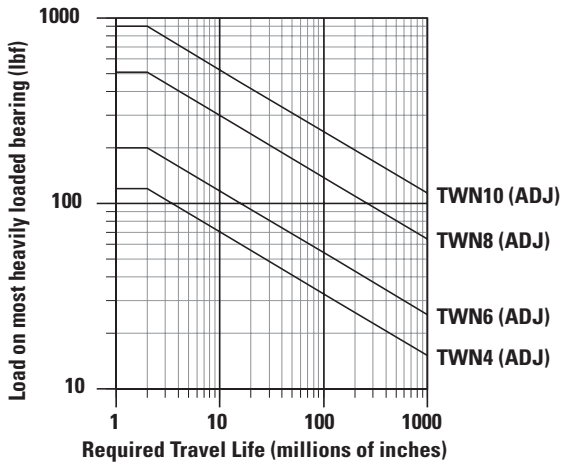

### Determining Ball Bushing Bearing Size

To determine the proper Ball Bushing Bearing size, enter the chart with the maximum load of the most heavily loaded bearing and the required travel life. Mark where the two lines intersect. All Ball Bushing Bearing sizes that pass through or above and to the right of this point may be suitable for this application.

**Note:** For the purpose of using this chart, load on most heavily loaded bearing = maximum applied load/ $K_0$ . Where  $K_0$  can be determined from the Polar Graph to the right.

## Polar Graphs

The actual dynamic load capacity of a Ball Bushing Bearing is determined by the orientation of the bearing or direction of the applied load. The load correction factor  $K_0$  is found by knowing the direction of the applied load relative to the orientation of the bearings ball tracks and referring to the polar graph. To determine the actual dynamic load capacity, multiply the proper correction factor by the dynamic load capacity listed in the product table on the previous page.

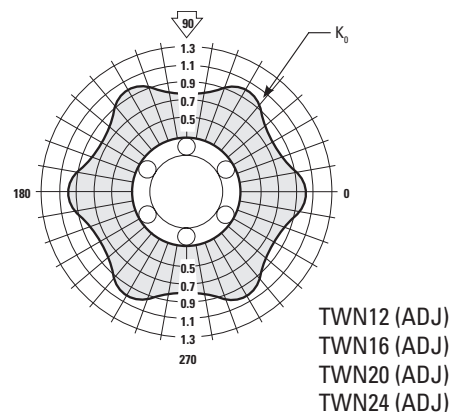
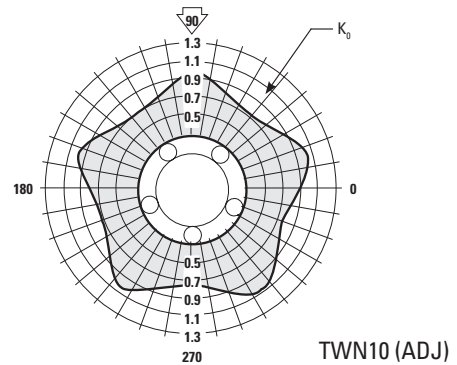
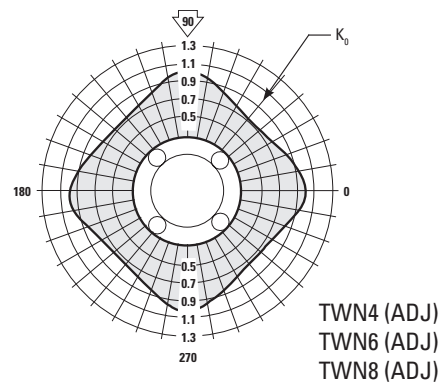

# Super Ball Bushing® Flanged Single and Twin Pillow Blocks for End-Supported Applications

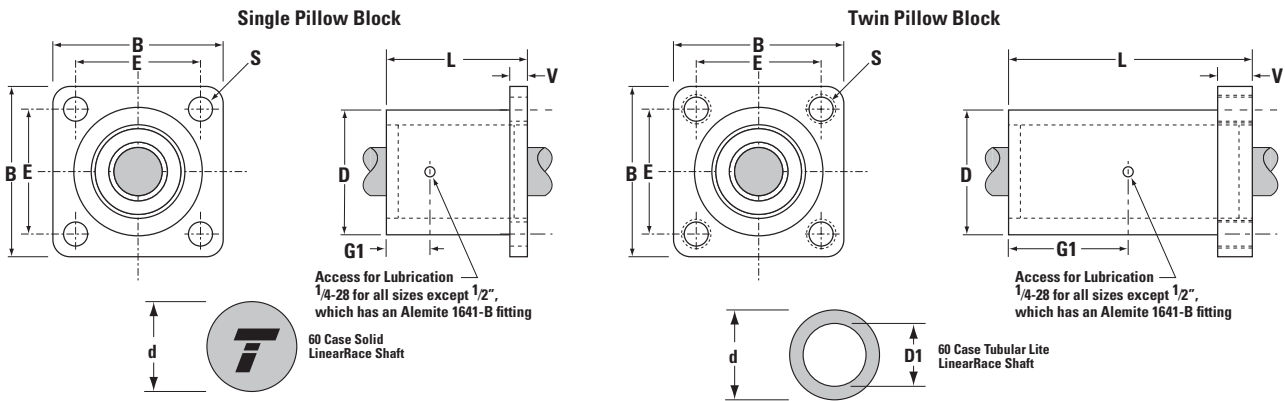
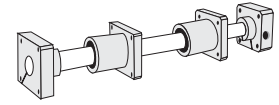

## Super Ball Bushing Flanged Pillow Blocks and 60 Case® LinearRace® Shaft (Dimensions in inches)

Part Number <sup>(1)</sup>		Nominal Diameter	B	E ±.010	L	D	V	G1	S Hole Dia.	60 Case LinearRace Diameter d	60 Case LinearRace Minimum Depth of Hardness	60 Case Solid LinearRace Mass lb/in	60 Case Tubular Lite LinearRace Mass lb/in	60 Case Tubular Lite LinearRace ID D1	Pillow Block Mass lb	Dynamic <sup>(2)</sup> Load Cap. lb <sub>f</sub>
Super Smart Ball Bushing Flanged Pillow Block	60 Case LinearRace															
SFB8	1/2 L	.500	1.63	1.250	1.69	1.25	.25	.72	.19	.4995/.4990	.04	.06	—	—	.23	255
SFB12	3/4 L	.750	2.38	1.750	2.06	1.75	.38	.89	.22	.7495/.7490	.06	.13	.08	.460/.416	.52	600
SFB16	1 L	1.000	2.75	2.125	2.81	2.25	.50	1.27	.28	.9995/.9990	.08	.22	.16	.629/.569	1.04	1050
SFB20	1 1/4 L	1.250	3.50	2.750	3.63	3.00	.63	1.67	.35	1.2495/1.2490	.08	.35	—	—	2.21	1500
SFB24	1 1/2 L	1.500	4.00	3.125	4.00	3.62	.75	1.86	.41	1.4994/1.4989	.08	.50	.33	.93/.84	3.68	2000

## Super Ball Bushing Flanged Twin Pillow Blocks and 60 Case LinearRace Shaft (Dimensions in inches)

Part Number <sup>(1)</sup>		Nominal Diameter	B	E ±.010	L	D	V	G1	S Thread	60 Case LinearRace Diameter d	60 Case LinearRace Minimum Depth of Hardness	60 Case Solid LinearRace Mass lb/in	60 Case Tubular Lite LinearRace Mass lb/in	60 Case Tubular Lite LinearRace ID D1	Pillow Block Mass lb	Dynamic <sup>(2)</sup> Load Cap. lb <sub>f</sub>
Super Smart Ball Bushing Flanged Twin Pillow Block	60 Case LinearRace															
TSFB8	1/2 L	.500	1.63	1.250	3.20	1.25	.90	1.48	1/4-20	.4995/.4990	.04	.06	—	—	.45	510
TSFB12	3/4 L	.750	2.38	1.750	3.95	1.75	.90	1.98	1/4-20	.7495/.7490	.06	.13	.08	.460/.416	1.05	1200
TSFB16	1 L	1.000	2.75	2.125	5.33	2.25	.90	2.67	5/16-18	.9995/.9990	.08	.22	.16	.629/.569	1.95	2100
TSFB20	1 1/4 L	1.250	3.50	2.750	6.70	3.00	.90	3.35	5/16-18	1.2495/1.2490	.08	.35	—	—	4.06	3000
TSFB24	1 1/2 L	1.500	4.00	3.125	7.50	3.62	1.00	3.75	3/8-16	1.4994/1.4989	.08	.50	.33	.93/.84	6.84	4000

(1) For part number description and specifications, see page 25.

(2) The Dynamic Load Capacity is based on a rated travel life of 2 million inches. The actual Dynamic Load Capacity can be affected by the orientation of the bearing or the direction of the applied load. For Dynamic Load Correction Factors, see following polar graphs. Dynamic load capacity for Twin configuration is based on two bearings equally loaded.

Note: For additional technical information, see the Engineering section beginning on page 256.



## Load/Life Graph

(Lines indicate limiting load for given Ball Bushing® Pillow Block)

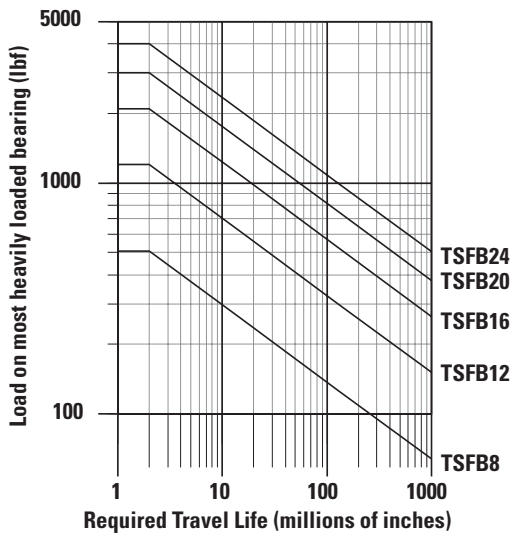
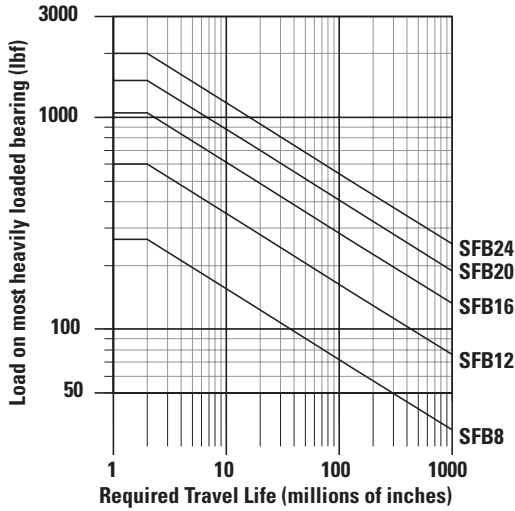

### Determining Ball Bushing Bearing Size

To determine the proper Ball Bushing Bearing size, enter the chart with the maximum load of the most heavily loaded bearing and the required travel life. Mark where the two lines intersect. All Ball Bushing Bearing sizes that pass through or above and to the right of this point may be suitable for this application.

**Note:** For the purpose of using this chart, load on most heavily loaded bearing = maximum applied load/ $K_0$ . Where  $K_0$  can be determined from the Polar Graph to the right.

## Polar Graphs

The actual dynamic load capacity of a Ball Bushing Bearing is determined by the orientation of the bearing or direction of the applied load. The load correction factor  $K_0$  is found by knowing the direction of the applied load relative to the orientation of the bearings ball tracks and referring to the polar graph. To determine the actual dynamic load capacity, multiply the proper correction factor by the dynamic load capacity listed in the product table on the previous page.

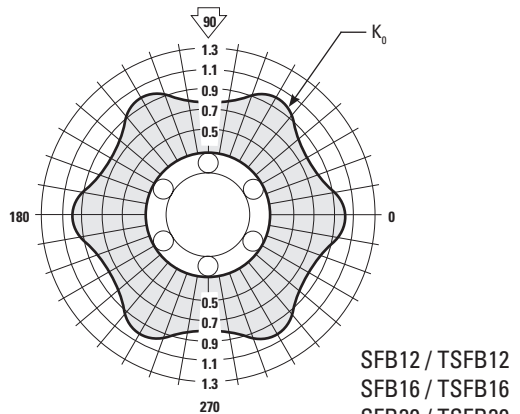
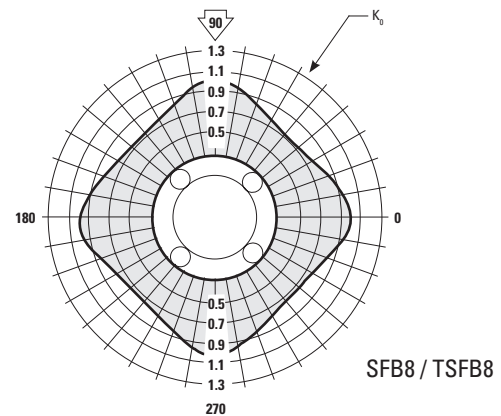

## Part Number Description and Specification

### Super Ball Bushing Bearings (Open Type) for Continuously Supported Applications

#### SUPER160PNDD-CR

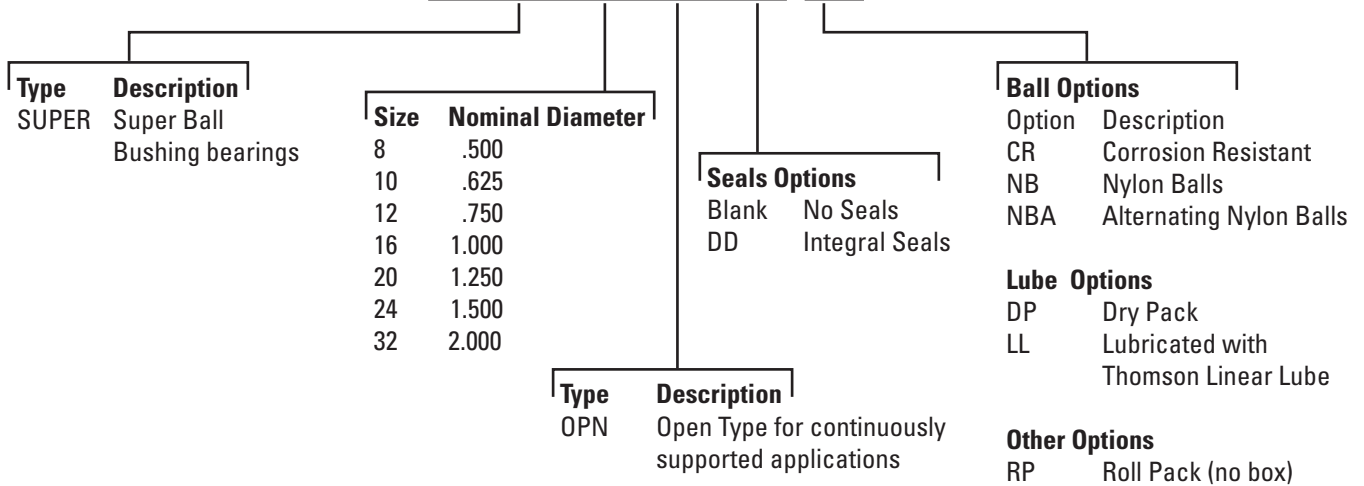

### Super Ball Bushing Pillow Blocks (Open Type) for Continuously Supported Applications

#### SPB160PN-CR

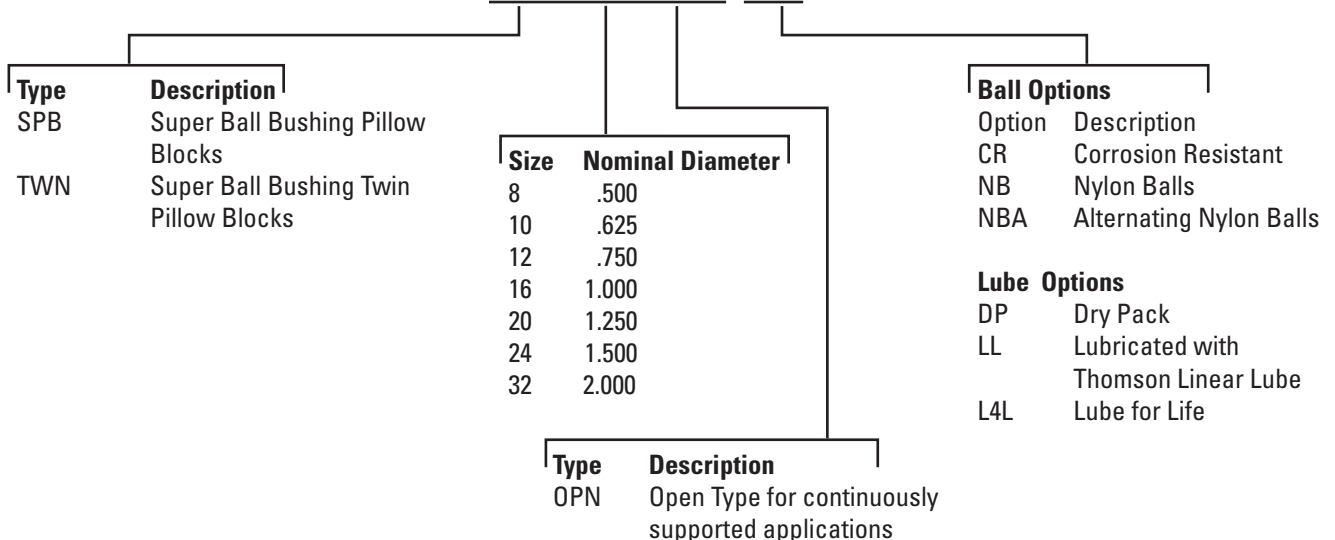

Not all options are available in all sizes.  
 See catalog pages or contact Thomson Customer Support for combination availability.  
 For additional information on bearing options, see page 267.



# Super Ball Bushing® Bearings (Open Type) for Continuously Supported Applications

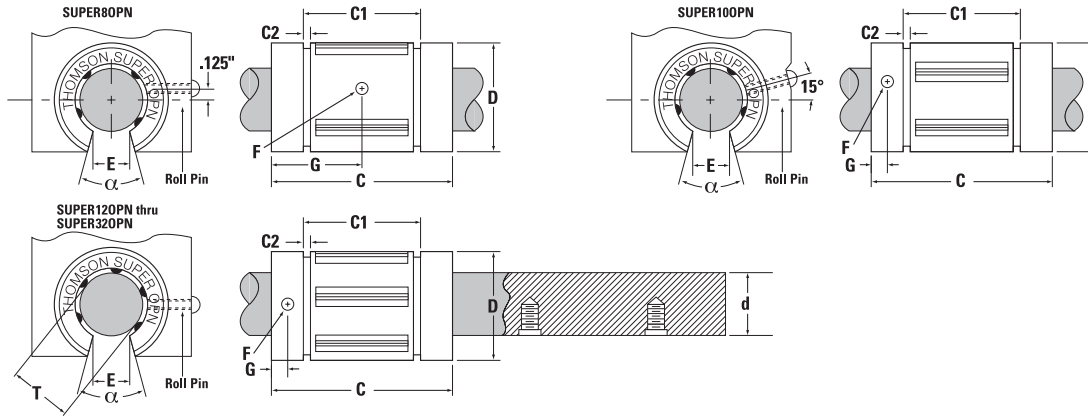
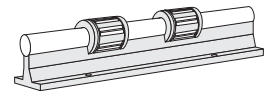

## Super Ball Bushing Bearings (Open Type) and 60 Case® LinearRace® (Dimensions in inches)

Part Number <sup>(1)</sup>		Nominal Diameter	Length C	Distance Between Retaining Rings C1	Ret. Ring Groove min. C2	Min. Slot Width E	Retention Hole		Angle deg α	Number of Ball Circuits	Ball Bushing Bearing Mass lb
Ball Bushing Bearing	60 Case Linear Race*						Dia. F	Loc. G			
SUPER80PN	1/2 L PD	.500	1.250/1.230	1.032/1.012	.050	.31	.14	.63	30	4	.04
SUPER100PN	5/8 L PD	.625	1.500/1.480	1.105/1.095	.056	.37	.11	.13	30	4	.08
SUPER120PN	3/4 L PD	.750	1.625/1.605	1.270/1.250	.056	.43	.14	.13	30	5	.12
SUPER160PN	1 L PD	1.000	2.250/2.230	1.884/1.864	.070	.56	.14	.13	30	5	.21
SUPER200PN	1 1/4 L PD	1.250	2.625/2.600	2.004/1.984	.068	.62	.20	.19	30	5	.38
SUPER240PN	1 1/2 L PD	1.500	3.000/2.970	2.410/2.390	.086	.75	.20	.19	30	5	.71
SUPER320PN	2 L PD	2.000	4.000/3.960	3.193/3.163	.105	1.00	.27	.31	30	5	1.20

\* 60 Case begins on page 176.

Part Number <sup>(1)</sup>	Working Bore Diameter T	Recommended Housing Bore Dia.		60 Case LinearRace Diameter d	Ball Bushing Bearing/LinearRace Fit Up ‡		Dynamic <sup>(2)</sup> Load Capacity lb <sub>r</sub>
		Fixed D	Adjustable D		Fixed Diameter Housing	Adjustable Diameter Housing (Before Adjustment)	
SUPER80PN	.5000/.4995	.8755/.8750	.8760/.8750	.4995/.4990	.0015C/.0000	.002C/.0000	230
SUPER100PN	.6250/.6245	1.1255/1.1250	1.1260/1.1250	.6245/.6240	.0015C/.0000	.002C/.0000	320
SUPER120PN	.7500/.7495	1.2505/1.2500	1.2510/1.2500	.7495/.7490	.0015C/.0000	.002C/.0000	470
SUPER160PN	1.0000/.9995	1.5630/1.5625	1.5635/1.5625	.9995/.9990	.0015C/.0000	.002C/.0000	780
SUPER200PN	1.2500/1.2494	2.0008/2.0000	2.0010/2.0000	1.2495/1.2490	.0018C/.0001P	.002C/.0001P	1170
SUPER240PN	1.5000/1.4994	2.3760/2.3750	2.3760/2.3750	1.4994/1.4989	.0021C/.0000	.0021C/.0000	1560
SUPER320PN	2.000/1.9992	3.0010/3.0000	3.0010/3.0000	1.9994/1.9987	.0023C/.0002P	.0023C/.0002P	2350

‡ P = Preload, C = Clearance

(1) For part number description and specifications, see page 59.

(2) The Dynamic Load Capacity is based on a rated travel life of 2 million inches. The actual Dynamic Load Capacity can be affected by the orientation of the bearing or the direction of the applied load. For Dynamic Load Correction Factors, see following polar graphs.

Note: For additional technical information, see the Engineering section beginning on page 256.

### Load/Life Graph

(Lines indicate limiting load for given Ball Bushing Pillow Block)

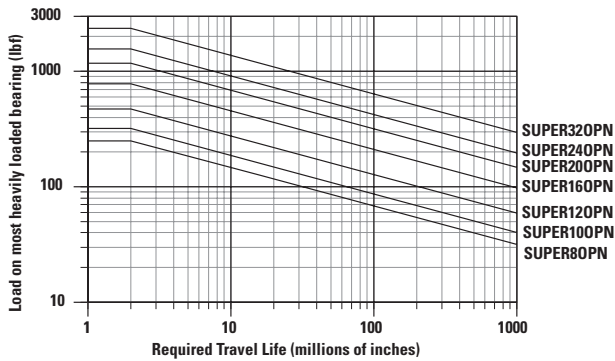

#### Determining Ball Bushing Bearing Size

To determine the proper Ball Bushing Bearing size, enter the chart with the maximum load of the most heavily loaded bearing and the required travel life. Mark where the two lines intersect. All Ball Bushing Bearing sizes that pass through or above and to the right of this point may be suitable for this application.

**Note:** For the purpose of using this chart, load on most heavily loaded bearing = maximum applied load/ $K_0$ . Where  $K_0$  can be determined from the Polar Graph to the right.

### Polar Graphs

The actual dynamic load capacity of a Ball Bushing Bearing is determined by the orientation of the bearing or direction of the applied load. The load correction factor  $K_0$  is found by knowing the direction of the applied load relative to the orientation of the bearings ball tracks and referring to the polar graph. To determine the actual dynamic load capacity, multiply the proper correction factor by the dynamic load capacity listed in the product table on the previous page.

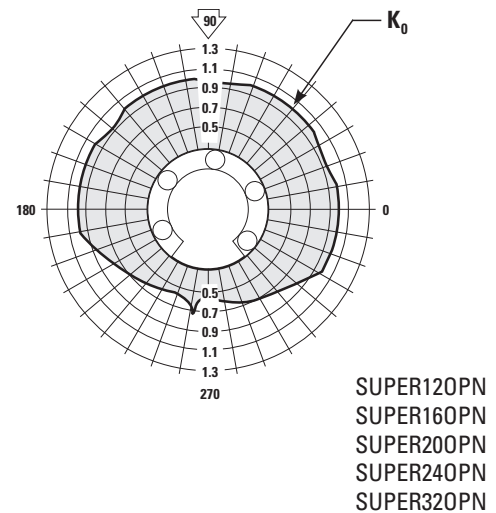
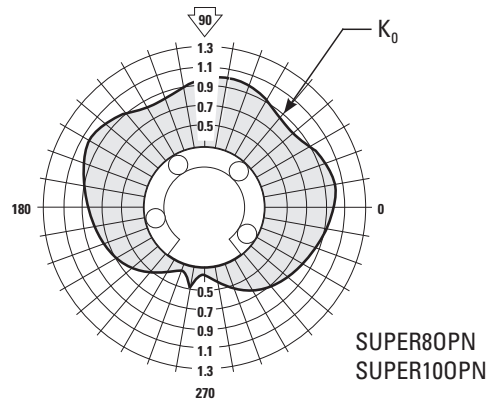



# Sealed Super Ball Bushing® Bearings (Open Type) for Continuously Supported Applications

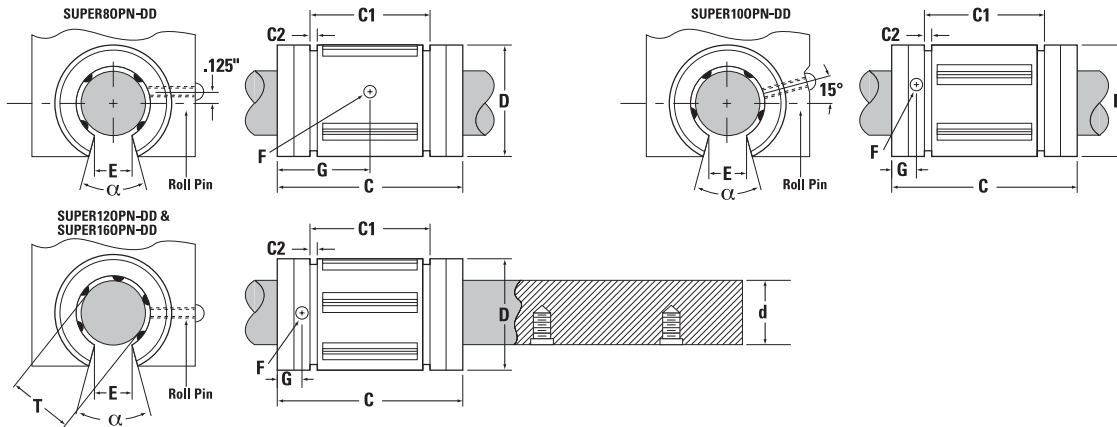
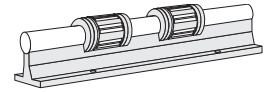

## Sealed Super Ball Bushing Bearings (Open Type, seal at both ends) and 60 Case® LinearRace® (Dimensions in inches)

Ball Bushing Bearing	60 Case Linear Race*	Nom. Dia.	Length C	Distance Between Retaining Rings C1	Ret. Ring Groove min. C2	Min. Slot Width E	Retention Hole		Angle deg α	Number of Ball Circuits	Ball Bushing Bearing Mass lb
							Dia. F	Loc. G			
SUPER80PN-DD	1/2 L PD	.500	1.500/1.460	1.032/1.012	.050	.31	.14	.750	30	4	.03
SUPER100PN-DD	5/8 L PD	.625	1.750/1.710	1.105/1.095	.056	.37	.11	.250	30	4	.08
SUPER120PN-DD	3/4 L PD	.750	1.875/1.835	1.270/1.250	.056	.43	.14	.250	30	5	.12
SUPER160PN-DD	1 L PD	1.000	2.625/2.585	1.884/1.864	.070	.56	.14	.313	30	5	.21

\* 60 Case begins on page 176.

Ball Bushing Bearing	Part Number (1)	Working Bore Diameter T	Recommended Housing Bore Dia.		60 Case LinearRace Diameter d	Ball Bushing Bearing/LinearRace Fit Up ‡		Dynamic (2) Load Capacity lb <sub>r</sub>
			Fixed D	Adjustable D		Fixed Diameter Housing	Adjustable Diameter Housing (Before Adjustment)	
SUPER80PN-DD		.5000/.4995	.8755/.8750	.8760/.8750	.4995/.4990	.0015C/.0000	.002C/.0000	230
SUPER100PN-DD		.6250/.6245	1.1255/1.1250	1.1260/1.1250	.6245/.6240	.0015C/.0000	.002C/.0000	320
SUPER120PN-DD		.7500/.7495	1.2505/1.2500	1.2510/1.2500	.7495/.7490	.0015C/.0000	.002C/.0000	470
SUPER160PN-DD		1.0000/.9995	1.5630/1.5625	1.5635/1.5625	.9995/.9990	.0015C/.0000	.002C/.0000	780

‡ P = Preload, C = Clearance

(1) For part number description and specifications, see page 59.

(2) The Dynamic Load Capacity is based on a rated travel life of 2 million inches. The actual Dynamic Load Capacity can be affected by the orientation of the bearing or the direction of the applied load. For Dynamic Load Correction Factors, see following polar graphs.

Note: For additional technical information, see the Engineering section beginning on page 256.

### Load/Life Graph

(Lines indicate limiting load for given Ball Bushing Pillow Block)

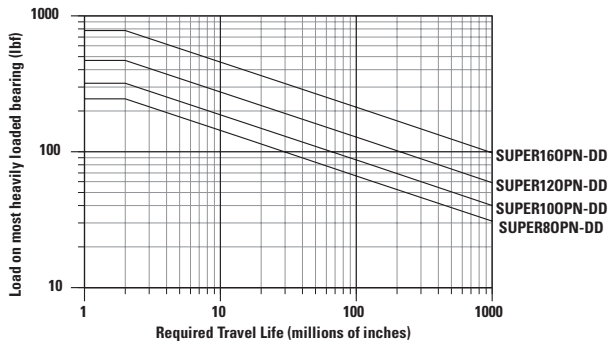

#### Determining Ball Bushing Bearing Size

To determine the proper Ball Bushing Bearing size, enter the chart with the maximum load of the most heavily loaded bearing and the required travel life. Mark where the two lines intersect. All Ball Bushing Bearing sizes that pass through or above and to the right of this point may be suitable for this application.

**Note:** For the purpose of using this chart, load on most heavily loaded bearing = maximum applied load/ $K_0$ . Where  $K_0$  can be determined from the Polar Graph to the right.

### Polar Graphs

The actual dynamic load capacity of a Ball Bushing Bearing is determined by the orientation of the bearing or direction of the applied load. The load correction factor  $K_0$  is found by knowing the direction of the applied load relative to the orientation of the bearings ball tracks and referring to the polar graph. To determine the actual dynamic load capacity, multiply the proper correction factor by the dynamic load capacity listed in the product table on the previous page.

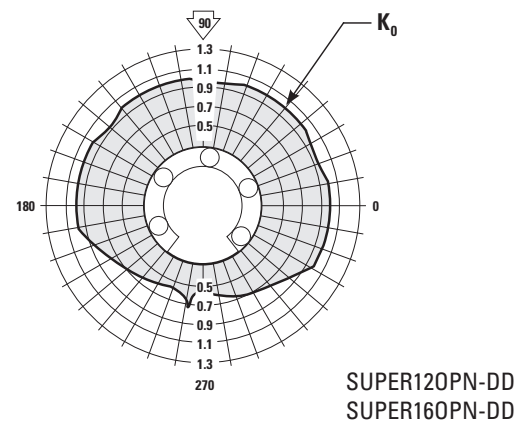
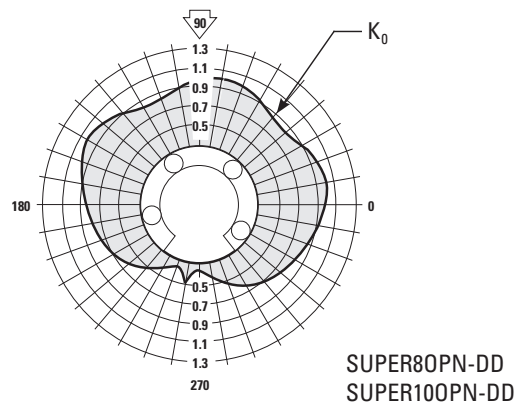



# Super Ball Bushing® Pillow Blocks (Open Type) for Continuously Supported Applications

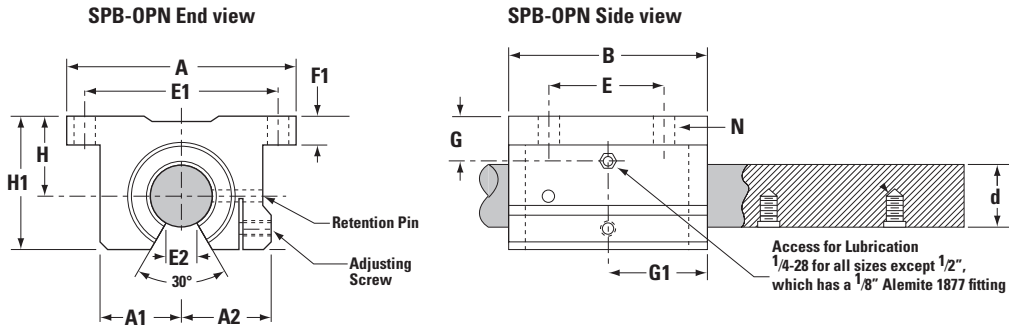
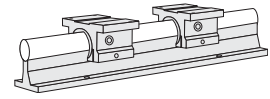

## Super Ball Bushing Pillow Blocks (Open Type, seal at both ends) and 60 Case® LinearRace® (Dimensions in inches)

Part Number <sup>(1)</sup>		Nominal Diameter	H ±.003	H1	A	A1	A2	B
Super Ball Bushing Pillow Block	60 Case LinearRace*							
SPB80PN	1/2 L PD	.500	.687	1.13	2.00	.69	.75	1.50
SPB100PN	5/8 L PD	.625	.875	1.44	2.50	.88	.94	1.75
SPB120PN	3/4 L PD	.750	.937	1.56	2.75	.94	1.00	1.88
SPB160PN	1 L PD	1.000	1.187	2.00	3.25	1.19	1.25	2.63
SPB200PN	1 1/4 L PD	1.250	1.500	2.50	4.00	1.50	1.63	3.38
SPB240PN	1 1/2 L PD	1.500	1.750	2.94	4.75	1.75	1.88	3.75
SPB320PN	2 L PD	2.000	2.125	3.63	6.00	2.25	2.44	4.75

\* 60 Case begins on page 176.

Part Number <sup>(1)</sup>	60 Case LinearRace Diameter d	E ±.010	E1 ±.010	E2 Min.	F1	G	G1	N		Pillow Block Mass lb	Dynamic <sup>(2)</sup> Load Capacity lb <sub>r</sub>
								Hole	Bolt		
SPB80PN	.4995/.4990	1.000	1.688	.31	.25	.50	.89	.16	#6	.2	230
SPB100PN	.6245/.6240	1.125	2.125	.37	.28	.55	.95	.19	#8	.4	320
SPB120PN	.7495/.7490	1.250	2.375	.43	.31	.67	1.08	.19	#8	.5	470
SPB160PN	.9995/.9990	1.750	2.875	.56	.38	.87	1.45	.22	#10	1.0	780
SPB200PN	1.2495/1.2490	2.000	3.500	.62	.44	1.15	1.83	.22	#10	2.1	1170
SPB240PN	1.4994/1.4989	2.500	4.125	.75	.50	1.28	2.02	.28	.25	3.2	1560
SPB320PN	1.9994/1.9987	3.250	5.250	1.00	.63	1.55	3.19	.41	.38	6.0	2350

(1) For part number description and specifications, see page 59.

(2) The Dynamic Load Capacity is based on a rated travel life of 2 million inches. The actual Dynamic Load Capacity can be affected by the orientation of the bearing or the direction of the applied load. For Dynamic Load Correction Factors, see following polar graphs.

Note: For additional technical information, see the Engineering section beginning on page 256.

### Load/Life Graph

(Lines indicate limiting load for given Ball Bushing Pillow Block)

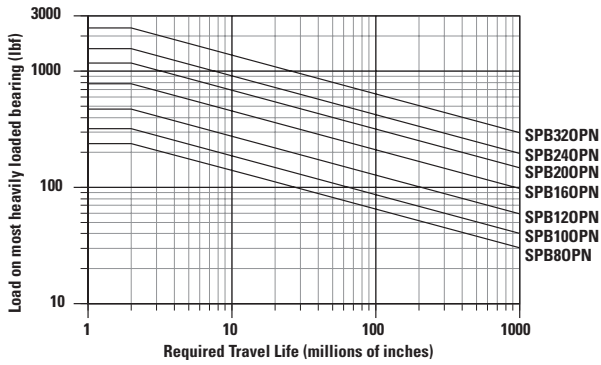

#### Determining Ball Bushing Bearing Size

To determine the proper Ball Bushing Bearing size, enter the chart with the maximum load of the most heavily loaded bearing and the required travel life. Mark where the two lines intersect. All Ball Bushing Bearing sizes that pass through or above and to the right of this point may be suitable for this application.

**Note:** For the purpose of using this chart, load on most heavily loaded bearing = maximum applied load/ $K_0$ . Where  $K_0$  can be determined from the Polar Graph to the right.

### Polar Graphs

The actual dynamic load capacity of a Ball Bushing Bearing is determined by the orientation of the bearing or direction of the applied load. The load correction factor  $K_0$  is found by knowing the direction of the applied load relative to the orientation of the bearings ball tracks and referring to the polar graph. To determine the actual dynamic load capacity, multiply the proper correction factor by the dynamic load capacity listed in the product table on the previous page.

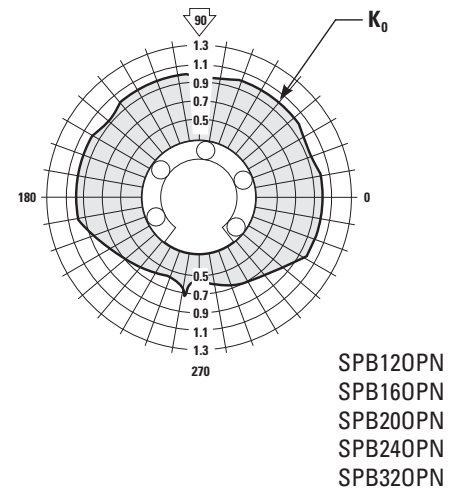
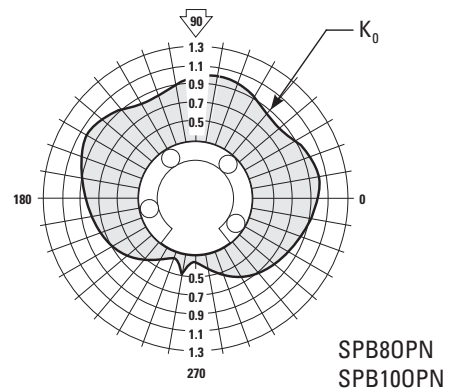



# Super Ball Bushing® Twin Pillow Blocks (Open Type) for Continuously Supported Applications

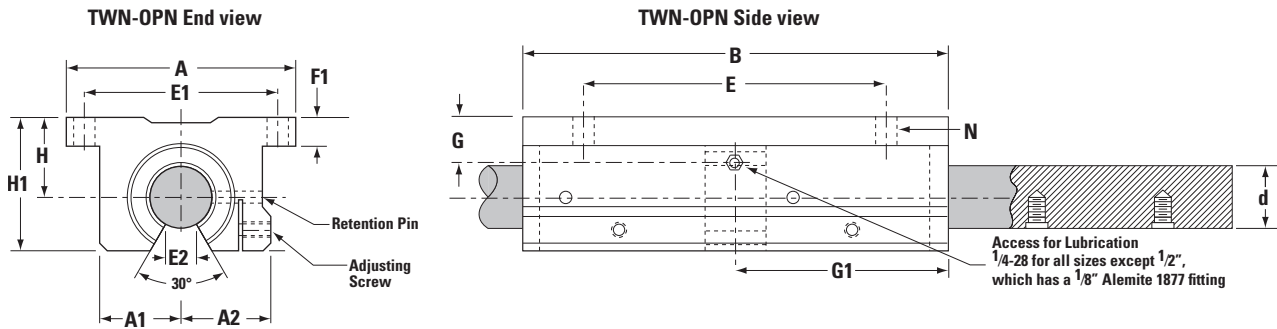
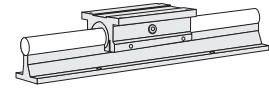

## Super Ball Bushing Twin Pillow Blocks (Open Type, seal at both ends) and 60 Case® LinearRace® (Dimensions in inches)

Part Number <sup>(1)</sup>		Nominal Diameter	H ±.003	H1	A	A1	A2	B
Super Ball Bushing Twin Pillow Block	60 Case LinearRace*							
TWN80PN	1/2 L PD	.500	.687	1.13	2.00	.69	.75	3.50
TWN100PN	5/8 L PD	.625	.875	1.44	2.50	.88	.94	4.00
TWN120PN	3/4 L PD	.750	.937	1.56	2.75	.94	1.00	4.50
TWN160PN	1 L PD	1.000	1.187	2.00	3.25	1.19	1.25	6.00
TWN200PN	1 1/4 L PD	1.250	1.500	2.50	4.00	1.50	1.63	7.50
TWN240PN	1 1/2 L PD	1.500	1.750	2.94	4.75	1.75	1.88	9.00

\* 60 Case begins on page 176.

Part Number <sup>(1)</sup> Super Ball Bushing Twin Pillow Block	60 Case LinearRace Diameter d	E ±.010	E1 ±.010	E2 Min.	F1	G	G1	N		Pillow Block Mass lb	Dynamic <sup>(2)</sup> Load Capacity lb <sub>i</sub>
								Hole	Bolt		
TWN80PN	.4995/.4990	2.500	1.688	.31	.25	.56	1.75	.16	#6	.4	460
TWN100PN	.6245/.6240	3.000	2.125	.37	.28	.67	2.00	.19	#8	.8	640
TWN120PN	.7495/.7490	3.500	2.375	.43	.31	.94	2.25	.19	#8	1.0	940
TWN160PN	.9995/.9990	4.500	2.875	.56	.38	1.20	3.00	.22	#10	2.0	1560
TWN200PN	1.2495/1.2490	5.500	3.500	.62	.44	1.50	3.75	.22	#10	4.2	2340
TWN240PN	1.4994/1.4989	6.500	4.125	.75	.50	1.75	4.50	.28	.25	6.7	3120

(1) For part number description and specifications, see page 59.

(2) The Dynamic Load Capacity is based on a rated travel life of 2 million inches. The actual Dynamic Load Capacity can be affected by the orientation of the bearing or the direction of the applied load, or Dynamic Load Correction Factors, see following polar graphs. Dynamic load capacity is based on two bearings equally loaded.

Note: For additional technical information, see the Engineering section beginning on page 256.

### Load/Life Graph

(Lines indicate limiting load for given Ball Bushing Pillow Block)

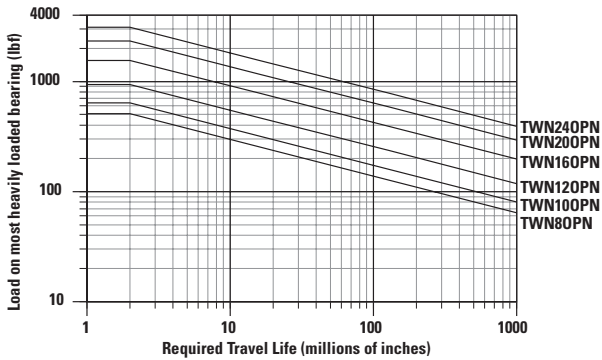

#### Determining Ball Bushing Bearing Size

To determine the proper Ball Bushing Bearing size, enter the chart with the maximum load of the most heavily loaded bearing and the required travel life. Mark where the two lines intersect. All Ball Bushing Bearing sizes that pass through or above and to the right of this point may be suitable for this application.

**Note:** For the purpose of using this chart, load on most heavily loaded bearing = maximum applied load/ $K_0$ . Where  $K_0$  can be determined from the Polar Graph to the right.

### Polar Graphs

The actual dynamic load capacity of a Ball Bushing Bearing is determined by the orientation of the bearing or direction of the applied load. The load correction factor  $K_0$  is found by knowing the direction of the applied load relative to the orientation of the bearings ball tracks and referring to the polar graph. To determine the actual dynamic load capacity, multiply the proper correction factor by the dynamic load capacity listed in the product table on the previous page.

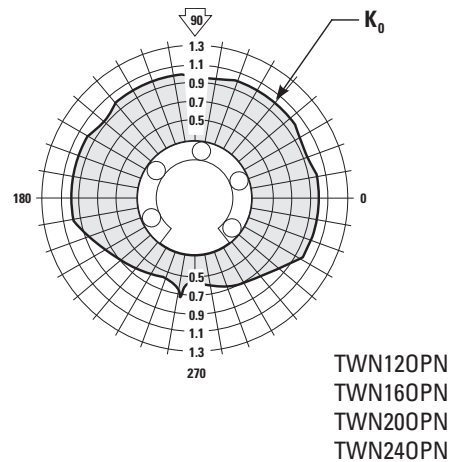
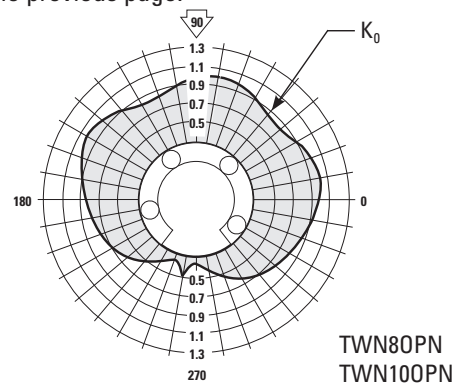



# Cam-Actuated Part Transfer Mechanism for Multiple-Transfer Press

## Objective

Improve production rate and increase the service life of a transfer table mechanism.

## Solution

Replace the conventional linear bearings with Adjustable Super Ball Bushing® Twin Pillow Blocks. Bearing service life increased to five years.

## Products Specified

2 - TWN16ADJ (Super Ball Bushing Twin Pillow Blocks)  
4 - ASB16 (60 Case® LinearRace® End Support Blocks)  
2 - 1 L CTL x 24.00 in (60 Case LinearRace)

## Benefits

The table achieved maximum cycle efficiency by reducing costly downtime and improving service life.

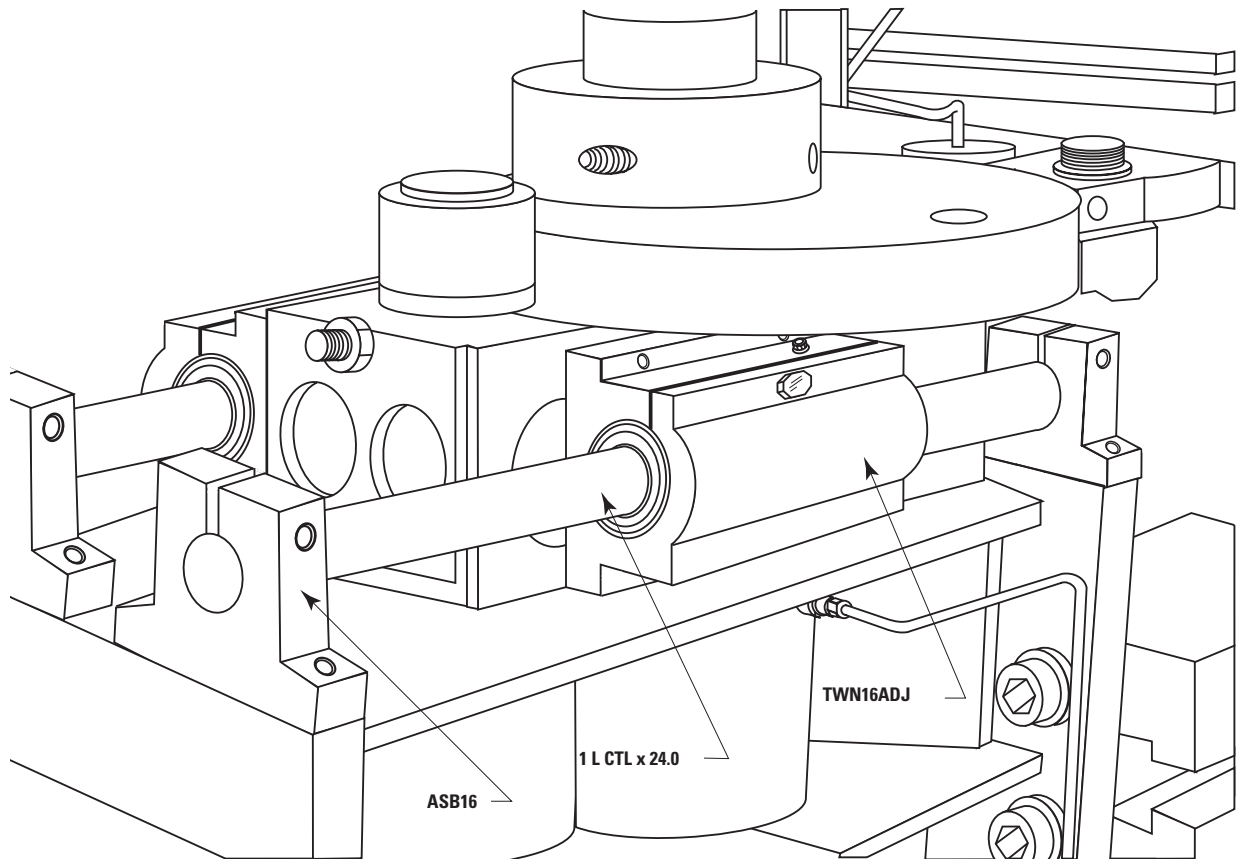

## Precision Steel Ball Bushing Bearing Products

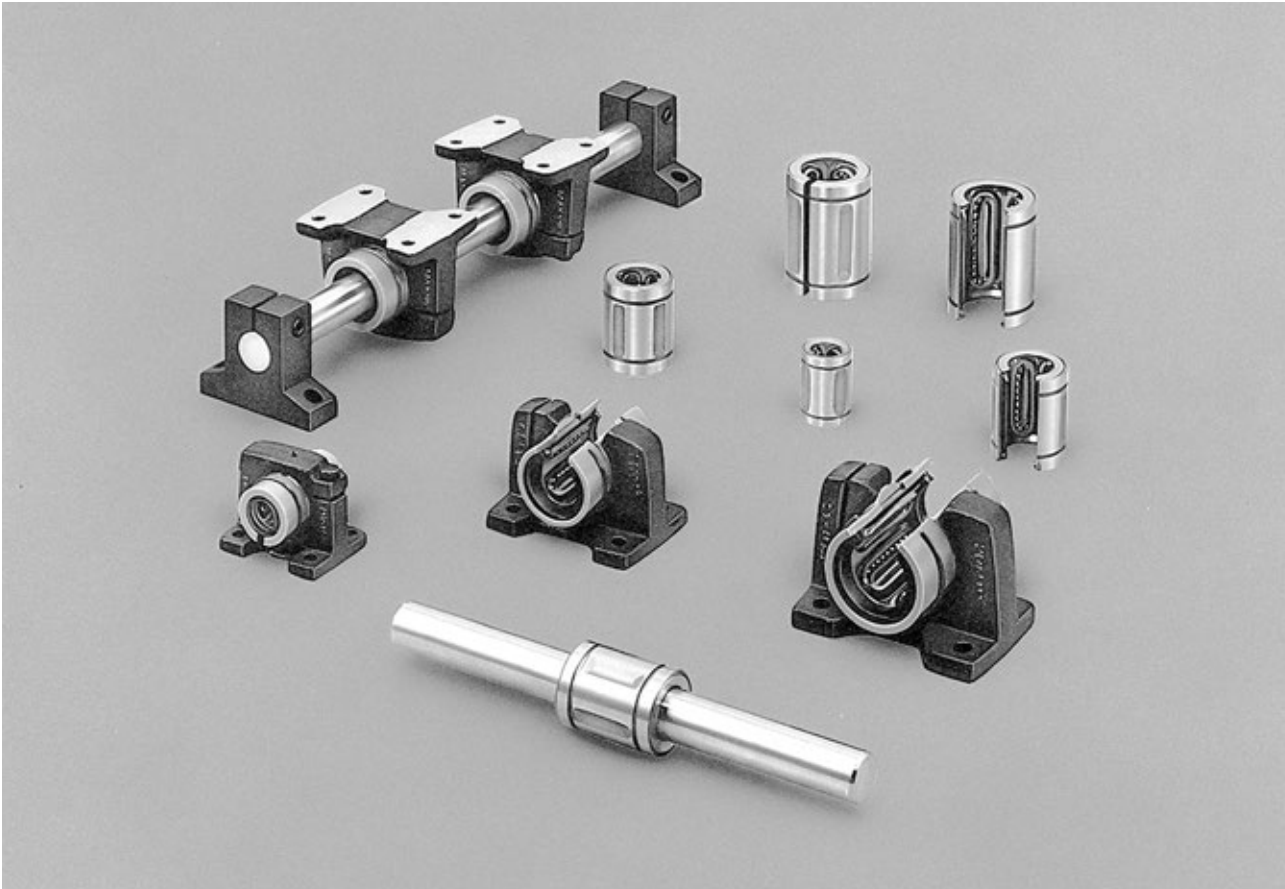

### Thomson Precision Steel Ball Bushing Bearing Products offer:

- A coefficient of friction as low as .001. When replacing high-friction plain bearings, Precision Steel Ball Bushing Bearings dramatically improve machine productivity and efficiency.
- All-steel construction for maximum system rigidity.
- Two accuracy classes allowing for immediate improvements in system positioning and repeatability.
- Availability in 14 bore sizes and nine configurations.
- The RoundRail Advantage, which minimizes installation time and cost.
- Steady state travel speeds up to 10 ft./s and accelerations to 450 ft./s<sup>2</sup> without the use of derating factors.
- An operating temperature up to 600°F / 315°C.
- Availability in a self-aligning pillow block housing for ease of installation and use.

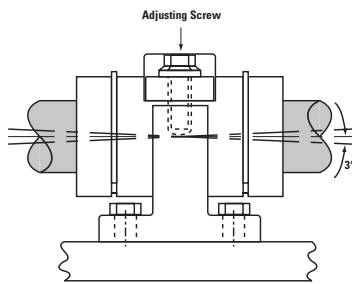

Figure 1

When the Precision Steel Ball Bushing Bearing is installed in its standard pillow block, it will self-align up to three degrees in all directions.

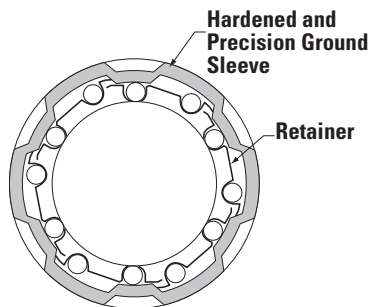

Figure 2

Precision Steel Ball Bushing Bearing cross-section

The basis for the performance of all Precision Steel Ball Bushing® Bearings is a simple but ingenious system of ball recirculation that permits almost frictionless, unlimited travel.

### Replace High-Friction Plain Bearings

Plain bearings cause friction, stick-slip, binding and chatter. The Precision Steel Ball Bushing Bearing's patented ball recirculation virtually eliminates wear and provides a constant coefficient of friction as low as .001. This dramatic reduction in friction allows the designer to use smaller, less expensive drive motors, ball screws, belts, linkages and gears.

### Lasting Precision Alignment

High-friction plain bearings cause wear, resulting in a loss in system alignment and repeatability. Each Precision Steel Ball Bushing Bearing is manufactured with high-quality bearing steel that is hardened and precision ground. The rolling elements of each Ball Bushing Bearing are precision, ground-bearing balls that recirculate freely into and out of the load zone. The balls are guided through their recirculation path by a steel retainer and hardened sleeve. The inherent, non-wear characteristics of each Precision Steel Ball Bushing Bearing assures maximum system accuracy and repeatability.

### High Travel Speeds

Precision Steel Ball Bushing Bearings can operate at travel rates as high as 10 ft./s and accelerations as high as 450 ft./s<sup>2</sup>. When replacing inefficient v-way or flat-way systems, this travel rate capability provides immediate improvements in machine efficiency and productivity.

### Ease of Installation

The Precision Steel Ball Bushing Bearing can be retained in a housing, internally or externally. The retaining ring groove on the outside diameter allows the bearing to be captured and retained by an external retaining ring. If internal retention is required, the Ball Bushing Bearing can be installed in a housing and held in place with an internal retaining ring.

### Protection from Contamination

Precision Steel Ball Bushing Bearings' most popular sizes are available with double-acting integral wipers that keep out contamination, retain lubrication and maximize travel life.

# Part Number Description and Specification

## Precision Steel Ball Bushing Bearings (Closed Type) for End Supported Applications

### A162536-DDSP

Type	Description	Size	Nom. Dia.	Seals Options	Ball Options
A	Precision Steel Ball Bushing Bearings	4812	.250	Blank No Seals DD Integral Seals	Option Description SS Stainless Steel (up to and including 1")
XA	Extra Precision Ball Bushing Bearings	81420	.500		SP Stainless Steel Balls, Black Oxide Retainer and Sleeve
ADJ	Adjustable Precision Steel Ball Bushing bearings	122026	.750		NB Nylon Balls
		162536	1.000		NBA Alternating Nylon Balls
		203242	1.250		<b>Lube Options</b>
		243848	1.500		DP Dry Pack
		324864	2.000		LL Lubricated with Thomson Linear Lube
		406080	2.500		
		487296	3.000		<b>Other Options</b>
		6496128	4.000		RP Roll Pack (no box)

## Precision Steel Ball Bushing Pillow Blocks (Closed Type) for End Supported Applications

### PB16ADJ-SS

Type	Description	Size	Nominal Diameter	Type	Description	Ball Options
PB	Precision Steel Ball Bushing Pillow Blocks	8	.500	A Standard ADJ Adjustable Type		Option Description SS Stainless Steel (up to and including 1")
		12	.750			SP Stainless Steel Balls, Black Oxide Retainer and Sleeve
		16	1.000			NB Nylon Balls
		20	1.250			NBA Alternating Nylon Balls
		24	1.500			<b>Lube Options</b>
		32	2.000			DP Dry Pack
				<b>Other Options</b>		
				HP Black Oxide, Reinforced Retainers		

Not all options are available in all sizes.  
See catalog pages or contact Thomson Customer Support for combination availability.  
For additional information on bearing options, see page 267.



# Precision Steel Ball Bushing® Bearings (Closed Type) for End-Supported Applications

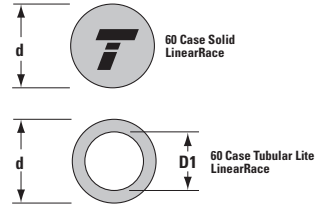
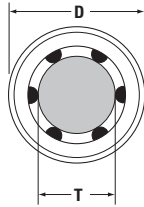
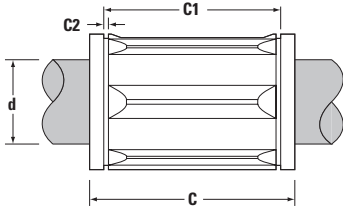
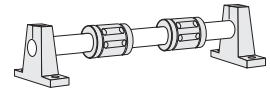

Sizes .250 thru 1.00 available in  
Corrosion Resistant Stainless Steel

## Precision Steel Ball Bushing Bearings (Closed Type) and 60 Case® LinearRace® (Dimensions in inches)

Part Number <sup>(1)</sup>		60 Case Linear Race	Nominal Diameter	Length C	Distance Between Retaining Grooves C1	Retaining Ring Groove min. C2	Number of Ball Circuits	D	60 Case Solid LinearRace Mass lb/in	60 Case Tubular Lite LinearRace Mass lb/in	60 Case Tubular Lite LinearRace ID D1
Precision Steel Ball Bushing Bearings											
w/o Seals	with Seals										
A4812	—	1/4 S	.250	.750/.735	.515/.499	.039	3	.5000/.4996	.01	—	—
A61014	—	3/8 S	.375	.875/.860	.640/.624	.039	4	.6250/.6246	.03	—	—
A81420	A81420-DD	1/2 S	.500	1.250/1.235	.967/.951	.046	4	.8750/.8746	.06	—	—
A101824	—	5/8 S	.625	1.500/1.485	1.108/1.092	.056	4	1.1250/1.1246	.09	—	—
A122026	A122026-DD	3/4 S	.750	1.625/1.610	1.170/1.154	.056	5	1.2500/1.2496	.13	.08	.46/.41
A162536	A162536-DD	1 S	1.000	2.250/2.235	1.759/1.741	.068	5	1.5625/1.5621	.22	.16	.62/.56
A203242	—	1 1/4 S	1.250	2.625/2.605	2.009/1.991	.068	6	2.0000/1.9995	.35	—	—
A243848	—	1 1/2 S	1.500	3.000/2.980	2.415/2.397	.086	6	2.3750/2.3745	.50	.33	.93/.84
A324864	—	2 S	2.000	4.000/3.980	3.195/3.177	.103	6	3.0000/2.9994	.89	.54	1.31/1.18
A406080	—	2 1/2 S	2.500	5.000/4.975	3.978/3.958	.120	6	3.7500/3.7492	1.39	.75	1.84/1.66
A487296	—	3 S	3.000	6.000/5.970	4.728/4.708	.120	6	4.5000/4.4990	2.00	1.11	2.20/1.80
A6496128	—	4 S	4.000	8.000/7.960	6.265/6.235	.139	6	6.0000/5.9988	3.56	1.56	3.30/2.70

Part Number <sup>(1)</sup>		Working Bore Diameter T	Recommended Housing Bore		60 Case LinearRace Diameter d	Precision Steel Ball Bushing Bearing/LinearRace Fit Up ‡	Precision Steel Ball Bushing Bearing Mass lb	Dynamic Load Capacity lb <sub>r</sub> <sup>(2)</sup>
Precision Steel Ball Bushing Bearings			Normal Fit	Press Fit				
w/o Seals	with Seals							
A4812	—	.2500/.2495	.5005/.5000	.4995/.4990	.2490/.2485	.0015C/.0005C	.02	19
A61014	—	.3750/.3745	.6255/.6250	.6245/.6240	.3740/.3735	.0015C/.0005C	.06	37
A81420	A81420-DD	.5000/.4995	.8755/.8750	.8745/.8740	.4990/.4985	.0015C/.0005C	.08	85
A101824	—	.6250/.6245	1.1255/1.1250	1.1245/1.1240	.6240/.6235	.0015C/.0005C	.16	150
A122026	A122026-DD	.7500/.7495	1.2505/1.2500	1.2495/1.2490	.7490/.7485	.0015C/.0005C	.21	200
A162536	A162536-DD	1.0000/.9995	1.5630/1.5625	1.5620/1.5615	.9990/.9985	.0015C/.0005C	.38	350
A203242	—	1.2500/1.2494	2.0010/2.0000	1.9993/1.9983	1.2490/1.2485	.0015C/.0004C	1.10	520
A243848	—	1.5000/1.4994	2.3760/2.3750	2.3743/2.3733	1.4989/1.4984	.0016C/.0005C	1.43	770
A324864	—	2.0000/1.9992	3.0010/3.0000	2.9992/2.9982	1.9987/1.9980	.0020C/.0005C	2.75	1100
A406080	—	2.5000/2.4990	3.7510/3.7500	Not Normally Recommended	2.4985/2.4977	.0023C/.0005C	5.50	1800
A487296	—	3.0000/2.9988	4.5010/4.5000		2.9983/2.9974	.0026C/.0005C	9.50	2600
A6496128	—	4.0000/3.9980	6.0010/6.0000		3.9976/3.9964	.0036C/.0004C	20.20	5000

‡ P = Preload, C = Clearance

(1) For part number description and specifications, see page 71.

(2) The Dynamic Load Capacity is based on a rated travel life of 2 million inches. The actual Dynamic Load Capacity can be affected by the orientation of the bearing or the direction of the applied load. For Dynamic Load Correction Factors, see following polar graphs.

### Load/Life Graph

(Lines indicate limiting load for given Ball Bushing Bearing)

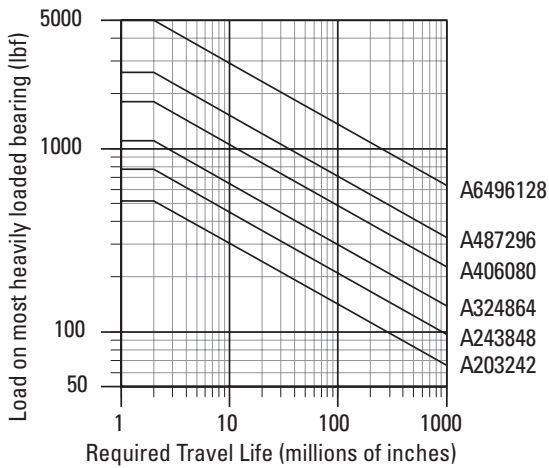
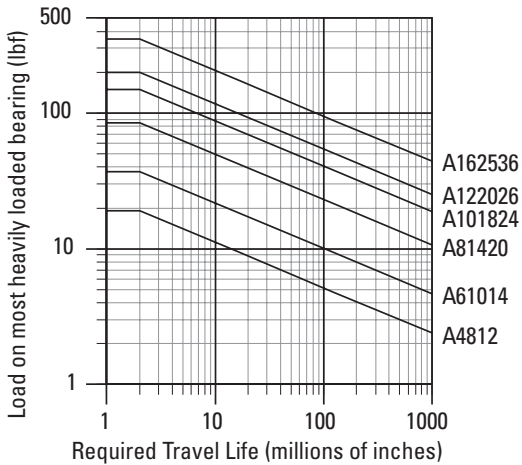

#### Determining Ball Bushing Bearing Size

To determine the proper Ball Bushing Bearing, size enter the chart with the maximum load of the most heavily loaded bearing and the required travel life. Mark where the two lines intersect. All Ball Bushing Bearing sizes that pass through or above and to the right of this point may be suitable for this application.

**Note:** For the purpose of using this chart, load on most heavily loaded bearing = maximum applied load/ $K_0$ . Where  $K_0$  can be determined from the Polar Graph to the right.

### Polar Graphs

The actual dynamic load capacity of a Ball Bushing Bearing is determined by the orientation of the bearing or direction of the applied load. The load correction factor  $K_0$  is found by knowing the direction of the applied load relative to the orientation of the bearings ball tracks and referring to the polar graph. To determine the actual dynamic load capacity, multiply the proper correction factor by the dynamic load capacity listed in the product table on the previous page.

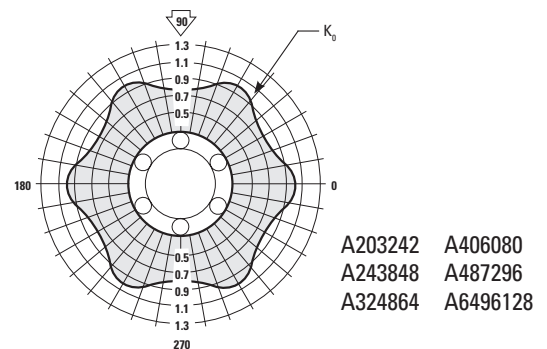
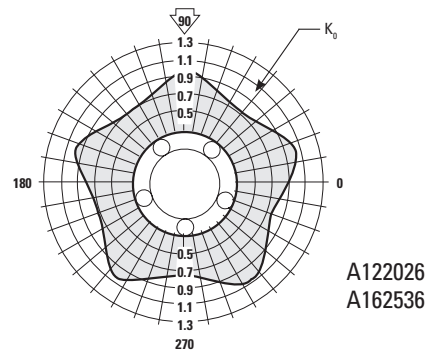
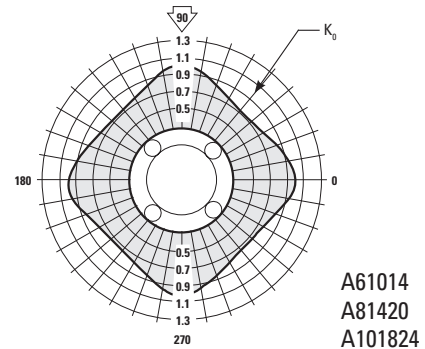
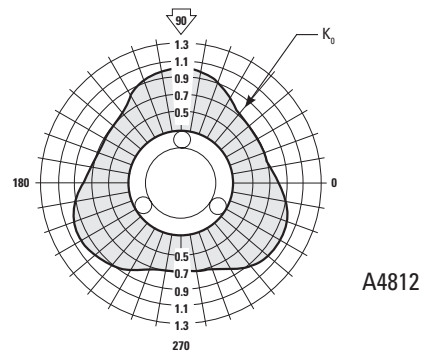



# Extra Precision Steel Ball Bushing® Bearings (Closed Type) for End-Supported Applications

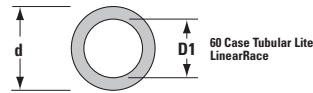
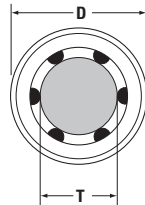
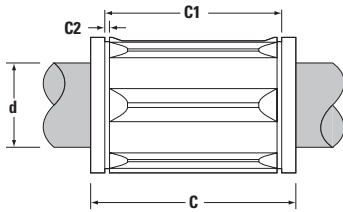
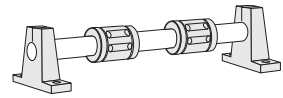

Sizes .250 thru 1.00 available in  
Corrosion Resistant Stainless Steel

## Extra Precision Steel Ball Bushing Bearings (Closed Type) and 60 Case® LinearRace® (Dimensions in inches)

Part Number <sup>(1)</sup>		60 Case Linear Race	Nominal Diameter	Length C	Distance Between Retaining Grooves C1	Retaining Ring Groove min. C2	Number of Ball Circuits	D	60 Case Solid LinearRace Mass lb/in	60 Case Tubular Lite LinearRace Mass lb/in	60 Case Tubular Lite LinearRace ID D1
Extra Precision Steel Ball Bushing Bearing	w/o Wipers										
XA4812	–	1/4 L	.250	.750/.735	.515/.499	.039	3	.5000/.4996	.01	–	–
XA61014	–	3/8 L	.375	.875/.860	.640/.624	.039	4	.6250/.6246	.03	–	–
XA81420	XA81420-DD	1/2 L	.500	1.250/1.235	.967/.951	.046	4	.8750/.8746	.06	–	–
XA101824	–	5/8 L	.625	1.500/1.485	1.108/1.092	.056	4	1.1250/1.1246	.09	–	–
XA122026	XA122026-DD	3/4 L	.750	1.625/1.610	1.170/1.154	.056	5	1.2500/1.2496	.13	.08	.46/.41
XA162536	XA162536-DD	1 L	1.000	2.250/2.235	1.759/1.741	.068	5	1.5625/1.5621	.22	.16	.62/.56
XA203242	–	1 1/4 L	1.250	2.625/2.605	2.009/1.991	.068	6	2.0000/1.9995	.35	–	–
XA243848	–	1 1/2 L	1.500	3.000/2.980	2.415/2.397	.086	6	2.3750/2.3745	.50	.33	.93/.84
XA324864	–	2 L	2.000	4.000/3.980	3.195/3.177	.103	6	3.0000/2.9994	.89	.54	1.31/1.18
XA406080	–	2 1/2 L	2.500	5.000/4.975	3.978/3.958	.120	6	3.7500/3.7492	1.39	.75	1.84/1.66
XA487296	–	3 L	3.000	6.000/5.970	4.728/4.708	.120	6	4.5000/4.4990	2.00	1.11	2.20/1.80
XA6496128	–	4 L	4.000	8.000/7.960	6.265/6.235	.139	6	6.0000/5.9988	3.56	1.56	3.30/2.70

Part Number <sup>(1)</sup>		Working Bore Diameter T	Recommended Housing Bore		60 Case LinearRace Diameter d	Precision Steel Ball Bushing Bearing/ LinearRace Fit Up ‡	Precision Steel Ball Bushing Bearing Mass lb	Dynamic <sup>(2)</sup> Load Capacity lb <sub>f</sub>
w/o Seals	with Seals		Normal Fit	Press Fit				
XA4812	–	.2500/.2497	.5005/.5000	Not Normally Recommended	.2495/.2490	.0010C/.0002C	.02	19
XA61014	–	.3750/.3747	.6255/.6250		.3745/.3740	.0010C/.0002C	.06	37
XA81420	XA81420-DD	.5000/.4997	.8755/.8750		.4995/.4990	.0010C/.0002C	.08	85
XA101824	–	.6250/.6247	1.1255/1.1250		.6245/.6240	.0010C/.0002C	.16	150
XA122026	XA122026-DD	.7500/.7497	1.2505/1.2500		.7495/.7490	.0010C/.0002C	.21	200
XA162536	XA162536-DD	1.0000/.9997	1.5630/1.5625		.9995/.9990	.0010C/.0002C	.38	350
XA203242	–	1.2500/1.2496	2.0010/2.0000		1.2495/1.2490	.0010C/.0001C	1.10	520
XA243848	–	1.5000/1.4996	2.3760/2.3750		1.4994/1.4989	.0011C/.0002C	1.43	770
XA324864	–	2.0000/1.9996	3.0010/3.0000		1.9994/1.9987	.0013C/.0002C	2.75	1100
XA406080	–	2.5000/2.4995	3.7510/3.7500		2.4993/2.4985	.0015C/.0002C	5.50	1800
XA487296	–	3.0000/2.9994	4.5010/4.5000		2.9992/2.9983	.0017C/.0002C	9.50	2600
XA6496128	–	4.0000/3.9990	6.0010/6.0000		3.9988/3.9976	.0024C/.0002C	20.20	5000

‡ P = Preload, C = Clearance

(1) For part number description and specifications see page 71.

(2) The Dynamic Load Capacity is based on a rated travel life of 2 million inches. The actual Dynamic Load Capacity can be affected by the orientation of the bearing or the direction of the applied load. For Dynamic Load Correction Factors, see following polar graphs.

### Load/Life Graph

(Lines indicate limiting load for given Ball Bushing Bearing)

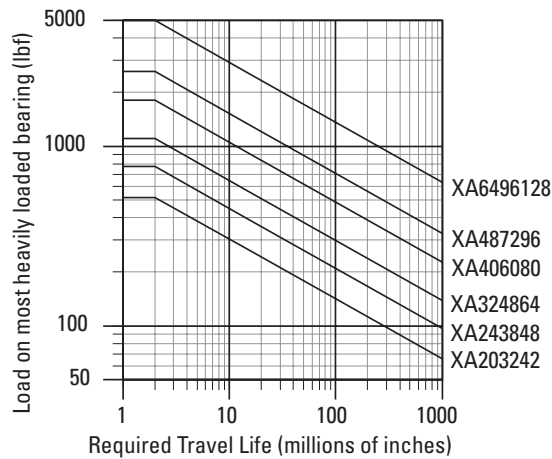
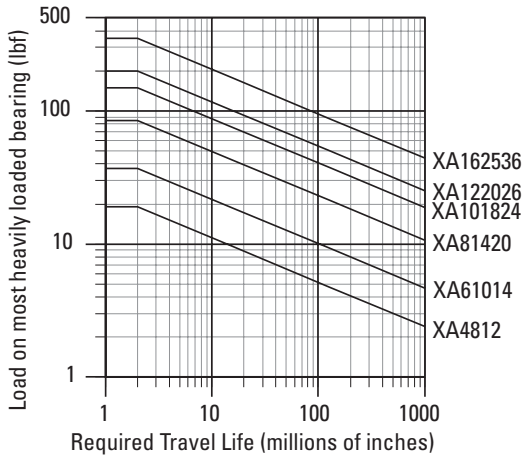

#### Determining Ball Bushing Bearing Size

To determine the proper Ball Bushing Bearing size, enter the chart with the maximum load of the most heavily loaded bearing and the required travel life. Mark where the two lines intersect. All Ball Bushing Bearing sizes that pass through or above and to the right of this point may be suitable for this application.

**Note:** For the purpose of using this chart, load on most heavily loaded bearing = maximum applied load/ $K_0$ . Where  $K_0$  can be determined from the Polar Graph to the right.

### Polar Graphs

The actual dynamic load capacity of a Ball Bushing Bearing is determined by the orientation of the bearing or direction of the applied load. The load correction factor  $K_0$  is found by knowing the direction of the applied load relative to the orientation of the bearings ball tracks and referring to the polar graph. To determine the actual dynamic load capacity, multiply the proper correction factor by the dynamic load capacity listed in the product table on the previous page.

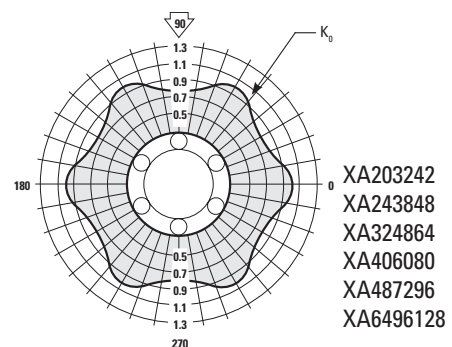
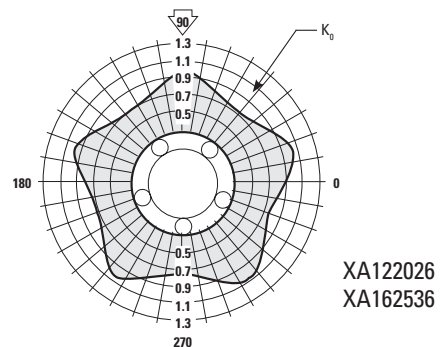
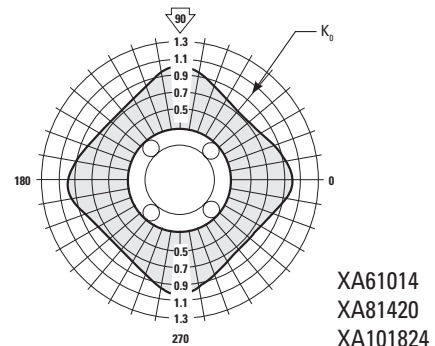
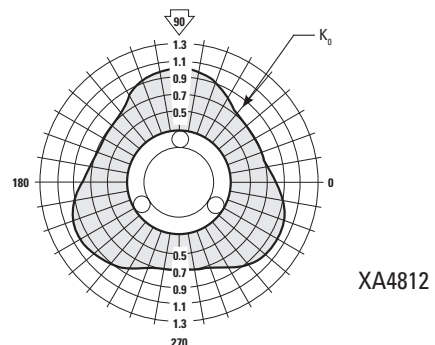



# Adjustable Precision Steel Ball Bushing® Bearings (Closed Type) for End-Supported Applications

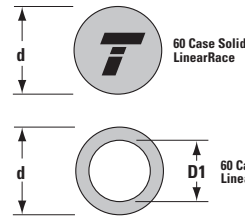
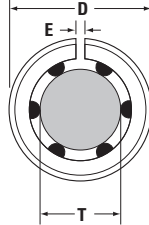
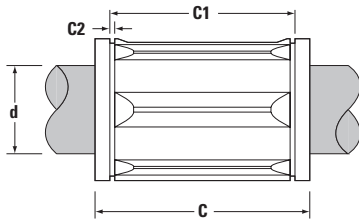
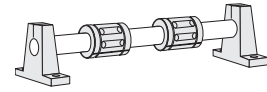

Sizes .250 thru 1.00 available in  
Corrosion Resistant Stainless Steel

## Adjustable Precision Steel Ball Bushing Bearings and 60 Case® LinearRace® (Dimensions in inches)

Part Number <sup>(1)</sup>		Nominal Diameter	Length C	Distance Between Retaining Grooves C1	Retaining Ring Groove min. C2	Min. Slot Width E	Number of Ball Circuits	60 Case LinearRace Minimum Depth of Hardness	60 Case Solid LinearRace Mass lb/in	60 Case Tubular Lite LinearRace Mass lb/in	60 Case Tubular Lite LinearRace ID D1
Precision Steel Ball Bushing Bearing	60 Case Linear Race										
ADJ81420	1/2 L	.500	1.250/1.235	.967/.951	.046	.06	4	.04	.06	—	—
ADJ101824	5/8 L	.625	1.500/1.485	1.108/1.092	.056	.09	4	.04	.09	—	—
ADJ122026	3/4 L	.750	1.625/1.610	1.170/1.154	.056	.09	5	.06	.13	.08	.46/.41
ADJ162536	1 L	1.000	2.250/2.235	1.759/1.741	.068	.09	5	.08	.22	.16	.62/.56
ADJ203242	1 1/4 L	1.250	2.625/2.605	2.009/1.991	.068	.09	6	.08	.35	—	—
ADJ243848	1 1/2 L	1.500	3.000/2.980	2.415/2.397	.086	.13	6	.08	.50	.33	.93/.84
ADJ324864	2 L	2.000	4.000/3.980	3.195/3.177	.103	.13	6	.10	.89	.54	1.31/1.18
ADJ406080	2 1/2 L	2.500	5.000/4.975	3.978/3.958	.120	.13	6	.10	1.39	.75	1.84/1.66
ADJ487296	3 L	3.000	6.000/5.970	4.728/4.708	.120	.13	6	.10	2.00	1.11	2.20/1.80
ADJ6496128	4 L	4.000	8.000/7.960	6.265/6.235	.139	.13	6	.10	3.56	1.56	3.30/2.70

Part Number <sup>(1)</sup>	Working Bore Diameter T	Recommended Housing Bore Diameter D	60 Case LinearRace Diameter d	Precision Steel Ball Bushing Bearing Mass lb	Dynamic Load Capacity lb <sub>r</sub>
		Normal Fit			
ADJ81420	.5000/.4995	.8755/.8750	.4995/.4990	.08	85
ADJ101824	.6250/.6245	1.1255/1.1250	.6245/.6240	.16	150
ADJ122026	.7500/.7495	1.2505/1.2500	.7495/.7490	.21	200
ADJ162536	1.0000/.9995	1.5630/1.5625	.9995/.9990	.38	350
ADJ203242	1.2500/1.2494	2.0010/2.0000	1.2495/1.2490	1.10	520
ADJ243848	1.5000/1.4994	2.3760/2.3750	1.4994/1.4989	1.43	770
ADJ324864	2.0000/1.9992	3.0010/3.0000	1.9994/1.9987	2.75	1100
ADJ406080	2.5000/2.4990	3.7510/3.7500	2.4993/2.4985	5.50	1800
ADJ487296	3.0000/2.9988	4.5010/4.5000	2.9992/2.9983	9.50	2600
ADJ6496128	4.0000/3.9980	6.0010/6.0000	3.9988/3.9976	20.20	5000

(1) For part number description and specifications see page 71.

(2) The Dynamic Load Capacity is based on a rated travel life of 2 million inches. The actual Dynamic Load Capacity can be affected by the orientation of the bearing or the direction of the applied load. For Dynamic Load Correction Factors, see following polar graphs.

### Load/Life Graph

(Lines indicate limiting load for given Ball Bushing Bearing)

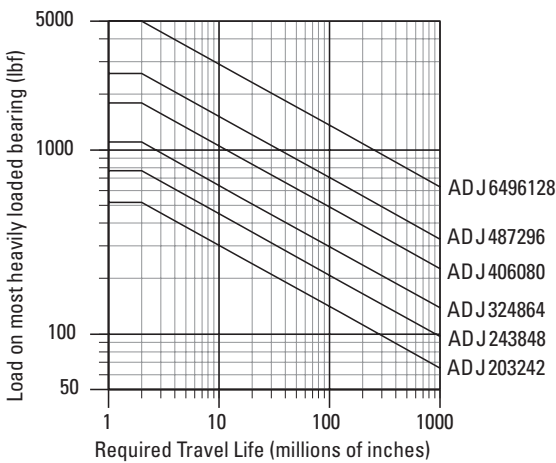
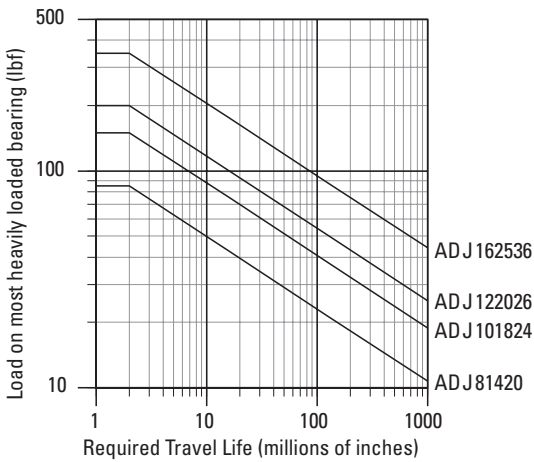

#### Determining Ball Bushing Bearing Size

To determine the proper Ball Bushing Bearing size, enter the chart with the maximum load of the most heavily loaded bearing and the required travel life. Mark where the two lines intersect. All Ball Bushing Bearing sizes that pass through or above and to the right of this point may be suitable for this application.

**Note:** For the purpose of using this chart, load on most heavily loaded bearing = maximum applied load/ $K_0$ . Where  $K_0$  can be determined from the Polar Graph to the right.

### Polar Graphs

The actual dynamic load capacity of a Ball Bushing Bearing is determined by the orientation of the bearing or direction of the applied load. The load correction factor  $K_0$  is found by knowing the direction of the applied load relative to the orientation of the bearings ball tracks and referring to the polar graph. To determine the actual dynamic load capacity, multiply the proper correction factor by the dynamic load capacity listed in the product table on the previous page.

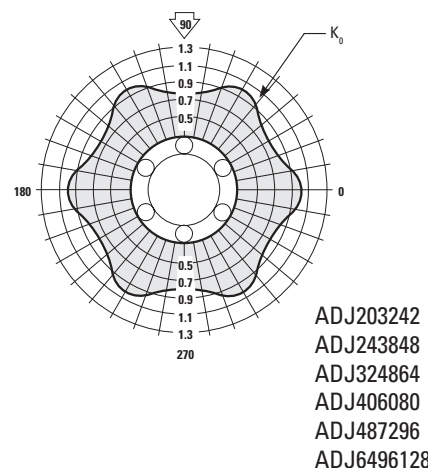
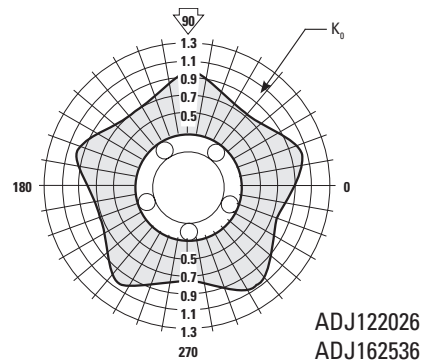
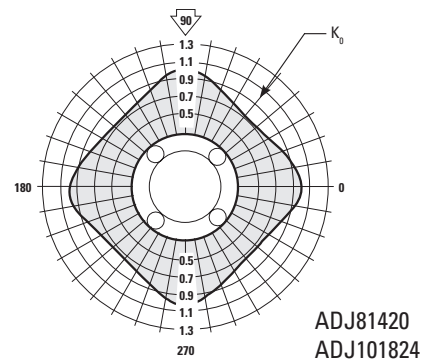



# Precision Steel Ball Bushing® Pillow Blocks (Closed and Adjustable Type) for End-Supported Applications

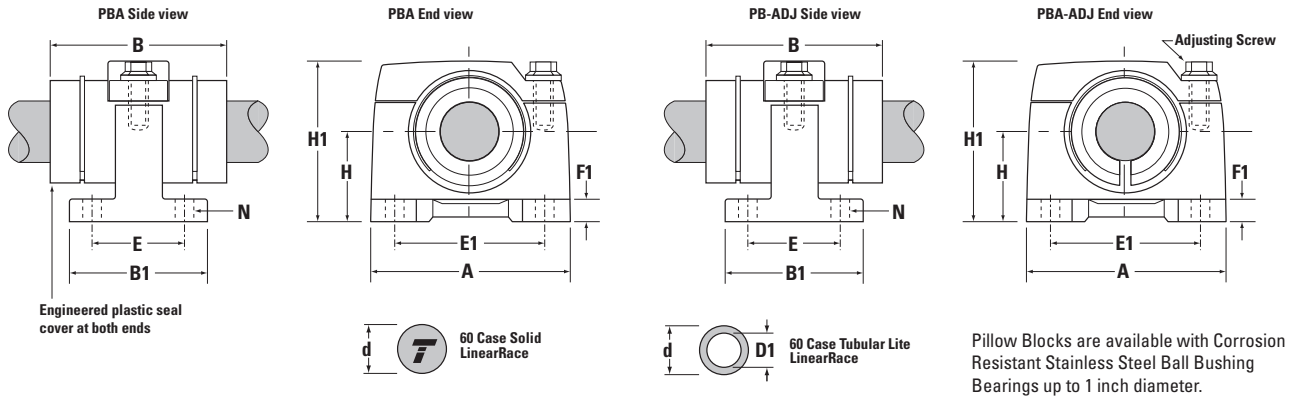
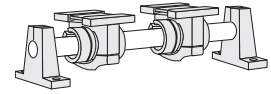

Pillow Blocks are available with Corrosion Resistant Stainless Steel Ball Bushing Bearings up to 1 inch diameter.

## Precision Steel Ball Bushing Pillow Blocks (Closed and Adjustable Type) and 60 Case® LinearRace® (Dimensions in inches)

Part Number <sup>(1)</sup>				Nom. Dia.	H ±.005	H1	Class S 60 Case LinearRace Diameter d	Class L 60 Case LinearRace Diameter d	60 Case LinearRace Minimum Depth of Hardness	60 Case Solid LinearRace Mass lb/in	60 Case Tubular Lite LinearRace Mass lb/in	60 Case Tubular Lite LinearRace ID D1
Precision Steel Ball Bushing Pillow Block	60 Case LinearRace Class S	Precision Steel Ball Bushing Pillow Block	60 Case LinearRace Class L									
Closed		Adjustable										
PB8A	1/2 S	PB8ADJ	1/2 L	.500	.875	1.63	.4990/.4985	.4995/.4990	.04	.06	—	—
PB12A	3/4 S	PB12ADJ	3/4 L	.750	1.125	2.13	.7490/.7485	.7495/.7490	.06	.13	.08	.46/.41
PB16A	1 S	PB16ADJ	1 L	1.000	1.375	2.56	.9990/.9985	.9995/.9990	.08	.22	.16	.62/.56
PB20A	1 1/4 S	PB20ADJ	1 1/4 L	1.250	1.750	3.25	1.2490/1.2485	1.2495/1.2490	.08	.35	—	—
PB24A	1 1/2 S	PB24ADJ	1 1/2 L	1.500	2.000	3.75	1.4989/1.4984	1.4994/1.4989	.08	.50	.33	.93/.84
PB32A	2 S	PB32ADJ	2 L	2.000	2.500	4.75	1.9987/1.9980	1.9994/1.9987	.10	.89	.54	1.31/1.18

Part Number <sup>(1)</sup>		A	B	B1	E ±.010	E1 ±.010	F1	N		Pillow Block Mass lb	Dynamic <sup>(2)</sup> Load Capacity lb <sub>f</sub>
Precision Steel Ball Bushing Pillow Block								Hole	Bolt		
Closed	Adjustable										
PB8A	PB8ADJ	2.00	1.69	1.50	1.000	1.500	.25	.19	#8	.5	85
PB12A	PB12ADJ	2.75	2.06	2.00	1.375	2.000	.31	.22	#10	1.3	200
PB16A	PB16ADJ	3.25	2.88	2.25	1.500	2.500	.38	.28	1/4	2.1	350
PB20A	PB20ADJ	4.00	3.63	2.75	1.875	3.000	.44	.34	5/16	4.4	520
PB24A	PB24ADJ	4.75	4.00	3.00	2.000	3.500	.50	.34	5/16	5.7	770
PB32A	PB32ADJ	6.00	5.00	3.50	2.500	4.500	.63	.41	3/8	10.5	1100

(1) For part number description and specifications see page 71.

(2) The Dynamic Load Capacity is based on a rated travel life of 2 million inches. The actual Dynamic Load Capacity can be affected by the orientation of the bearing or the direction of the applied load. For Dynamic Load Correction Factors, see following polar graphs.

Note: Check bearing clearance when using Thomson end supports.

## Load/Life Graph

(Lines indicate limiting load for given Ball Bushing Bearing)

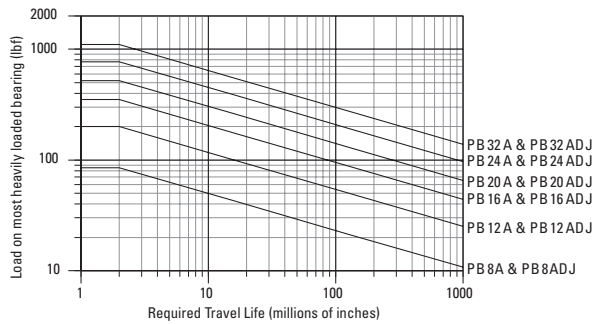

### Determining Ball Bushing Bearing Size

To determine the proper Ball Bushing Bearing size, enter the chart with the maximum load of the most heavily loaded bearing and the required travel life. Mark where the two lines intersect. All Ball Bushing Bearing sizes that pass through or above and to the right of this point may be suitable for this application.

**Note:** For the purpose of using this chart, load on most heavily loaded bearing = maximum applied load/ $K_0$ . Where  $K_0$  can be determined from the Polar Graph to the right.

## Polar Graphs

The actual dynamic load capacity of a Ball Bushing Bearing is determined by the orientation of the bearing or direction of the applied load. The load correction factor  $K_0$  is found by knowing the direction of the applied load relative to the orientation of the bearings ball tracks and referring to the polar graph. To determine the actual dynamic load capacity, multiply the proper correction factor by the dynamic load capacity listed in the product table on the previous page.

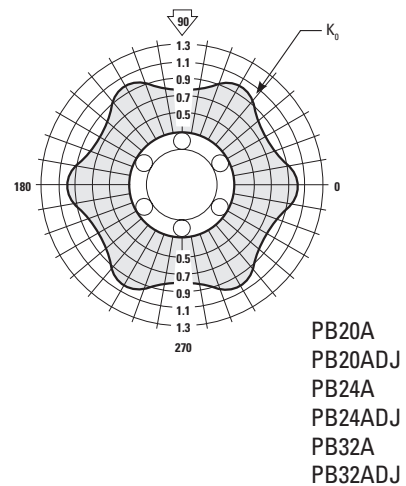
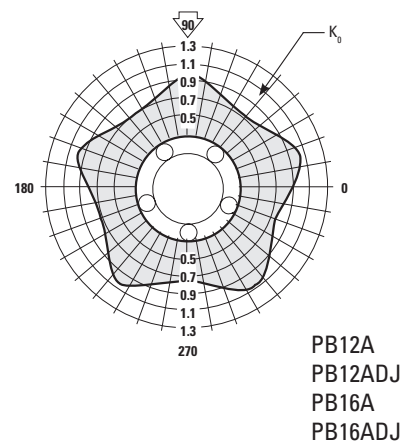
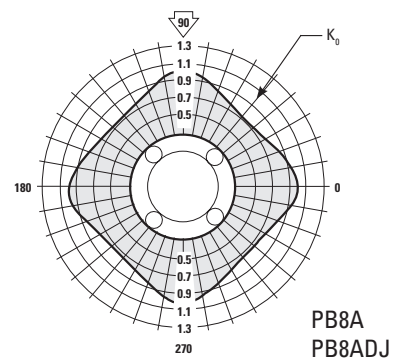



# Miniature Instrument Ball Bushing<sup>®</sup> Bearing and 60 Case<sup>®</sup> LinearRace<sup>®</sup> Sets

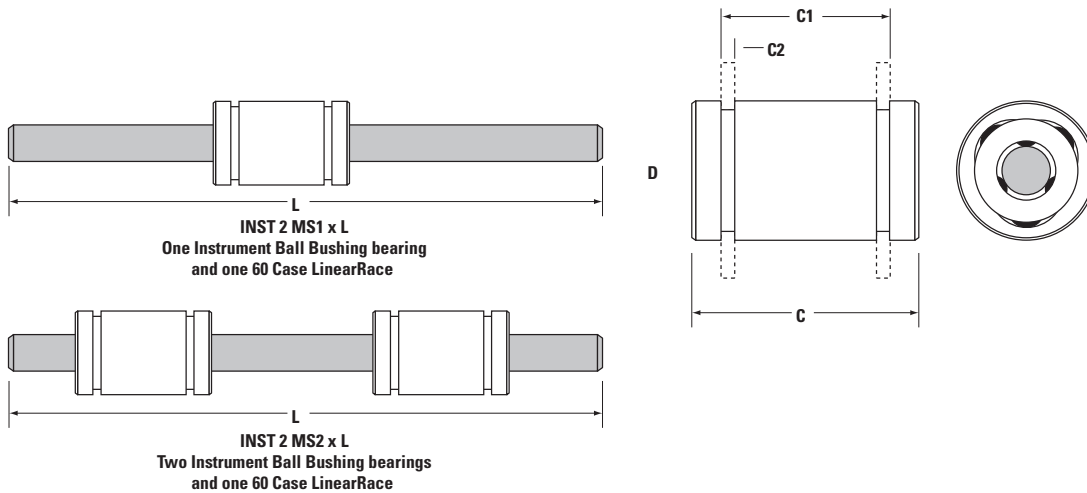
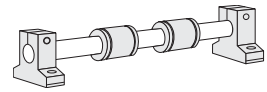

## Miniature Instrument Ball Bushing Bearings and 60 Case LinearRace Sets (Dimensions in inches)

Part Number		Nominal Diameter	Outside Diameter D	Ball Bushing Bearing Length C	Distance Between Retaining Rings C1	Retaining Ring Groove min. C2	Recommended ± Housing Bore	Number of Ball Circuits	Ball Bushing Bearing Mass lb/in	60 Case LinearRace Mass lb/in
One Bearing	Two Bearings									
INST2MS1	INST2MS2	.1250	.3125/.3121	.500/.485	.354	.028	.3130/.3124	3	.007	.004
INST3MS1	INST3MS2	.1875	.3750/.3746	.562/.547	.417	.028	.3755/.3749	3	.011	.008
INST4MS1	INST4MS2	.2500	.5000/.4996	.750/.735	.499	.039	.5005/.4999	3	.025	.014

## Miniature Instrument Ball Bushing Bearings (Dimensions in inches)

Part Number	Working Bore Diameter	LinearRace Maximum Length	60 Case LinearRace Diameter d	Instrument Ball Bushing Bearing/LinearRace Set Fit Up	Dynamic <sup>(1)</sup> Load Capacity lb <sub>f</sub>
INST258SS	.1250/.1247	12	.1248/.1247	.0003C/.0001C	7
INST369SS	.1875/.1872	12	.1873/.1872	.0003C/.0001C	9
INST4812SS	.2500/.2497	12	.2498/.2497	.0003C/.0001C	19

‡ Press fit not recommended.

(1) The Dynamic Load Capacity is based on a rated travel life of 2 million inches. The actual Dynamic Load Capacity can be affected by the orientation of the bearing or the direction of the applied load. For Dynamic Load Correction Factors, see following polar graphs. Dynamic load capacity for MS2 configuration is based on two bearings equally loaded.

Note: For additional technical information, see the Engineering section beginning on page 256.

## Part Number Description

### INST 2 MS1 x L3.0

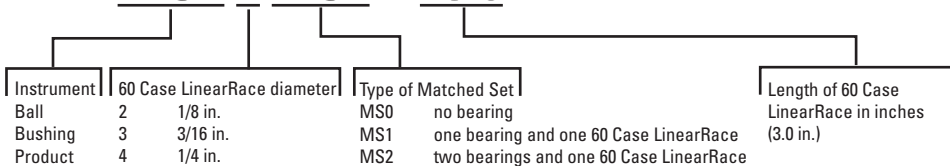

**60 Case LinearRace Specifications**  
 Material: 440 Stainless Steel  
 Hardness: 55 HRC minimum  
 Surface Finish: 4 R<sub>a</sub> microinch  
 Straightness: .0001 inch per inch

### Load/Life Graph

(Lines indicate limiting load for given Ball Bushing Bearing)

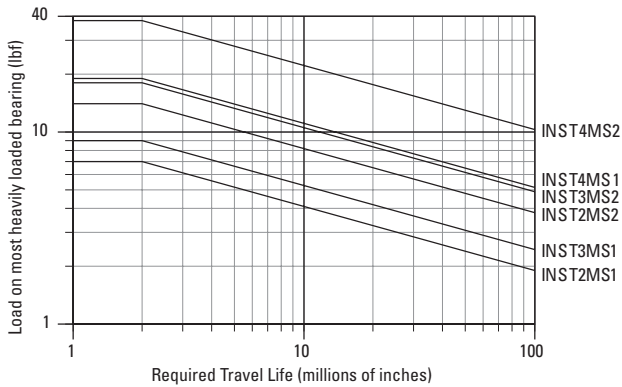

#### Determining Ball Bushing Bearing Size

To determine the proper Ball Bushing Bearing size, enter the chart with the maximum load of the most heavily loaded bearing and the required travel life. Mark where the two lines intersect. All Ball Bushing Bearing sizes that pass through or above and to the right of this point may be suitable for this application.

**Note:** For the purpose of using this chart, load on most heavily loaded bearing = maximum applied load/ $K_0$ . Where  $K_0$  can be determined from the Polar Graph to the right.

### Polar Graphs

The actual dynamic load capacity of a Ball Bushing Bearing is determined by the orientation of the bearing or direction of the applied load. The load correction factor  $K_0$  is found by knowing the direction of the applied load relative to the orientation of the bearings ball tracks and referring to the polar graph. To determine the actual dynamic load capacity, multiply the proper correction factor by the dynamic load capacity listed in the product table on the previous page.

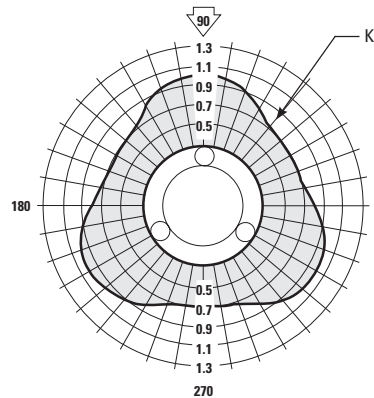

INST258SS  
INST369SS  
INST4812SS



# Die Set Ball Bushing® Bearings for End-Supported Applications

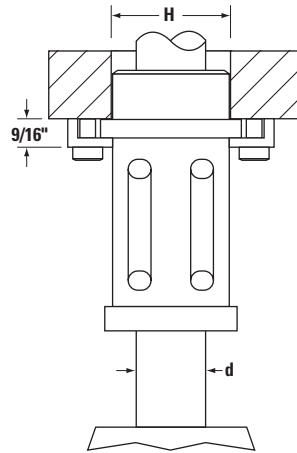
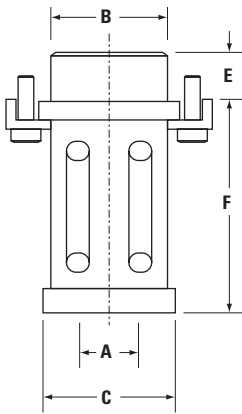
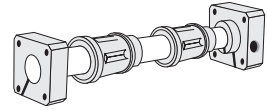

## Precision Series Die Set Ball Bushing Bearings and 60 Case® LinearRace® (Dimensions in inches)

Part Number		Nominal Diameter	60 Case LinearRace Diameter d	Working Bore Diameter A	Ball Bushing Pilot Diameter B	O.D. C	Ball Bushing Bearing Pilot Length E	F	Bearing Weight lb	Recommended Mounting Hole Diameter H	Concentricity of Pilot (B) to Bearing Bore (A) (TIR)	Dynamic <sup>(1)</sup> Load Capacity lb <sub>f</sub>
DS Ball Bushing Bearing	60 Case Linear Race											
DS16	1 D	1.000	1.0003/1.0000	.9999/.9996	1.5007/1.5003	1.91	.94	3.17	1.350	1.5005/1.5000	.0007	350
DS20	1 1/4 D	1.250	1.2503/1.2500	1.2498/1.2495	1.7507/1.7503	2.31	1.19	3.67	2.145	1.7505/1.7500	.0007	520
DS24	1 1/2 D	1.500	1.5003/1.5000	1.4997/1.4994	2.0007/2.0003	2.72	1.44	4.17	3.255	2.0005/2.0000	.0007	770
DS32	2 D	2.000	2.0003/2.0000	1.9995/1.9992	2.5007/2.5003	3.53	1.94	4.42	5.640	2.5005/2.5000	.0007	1100

(1) The Dynamic Load Capacity is based on a rated travel life of 2 million inches. The actual Dynamic Load Capacity can be affected by the orientation of the bearing or the direction of the applied load. For Dynamic Load Correction Factors, see following polar graphs.  
Note: For additional technical information, see the Engineering section beginning on page 256.

### Load/Life Graph

(Lines indicate limiting load for given Ball Bushing Bearing)

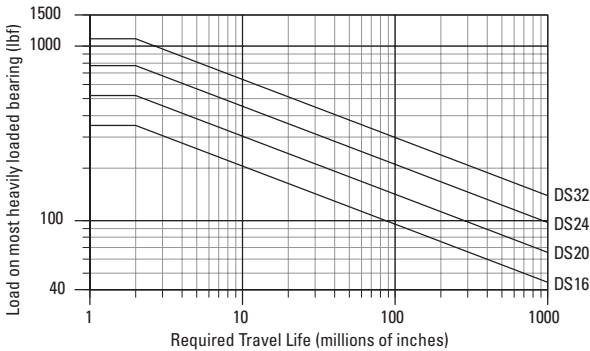

### Determining Ball Bushing Bearing Size

To determine the proper Ball Bushing Bearing size, enter the chart with the maximum load of the most heavily loaded bearing and the required travel life. Mark where the two lines intersect. All Ball Bushing Bearing sizes that pass through or above and to the right of this point may be suitable for this application.

**Note:** For the purpose of using this chart, load on most heavily loaded bearing = maximum applied load/ $K_0$ . Where  $K_0$  can be determined from the Polar Graph to the right.

### Polar Graphs

The actual dynamic load capacity of a Ball Bushing Bearing is determined by the orientation of the bearing or direction of the applied load. The load correction factor  $K_0$  is found by knowing the direction of the applied load relative to the orientation of the bearings ball tracks and referring to the polar graph. To determine the actual dynamic load capacity, multiply the proper correction factor by the dynamic load capacity listed in the product table on the previous page.

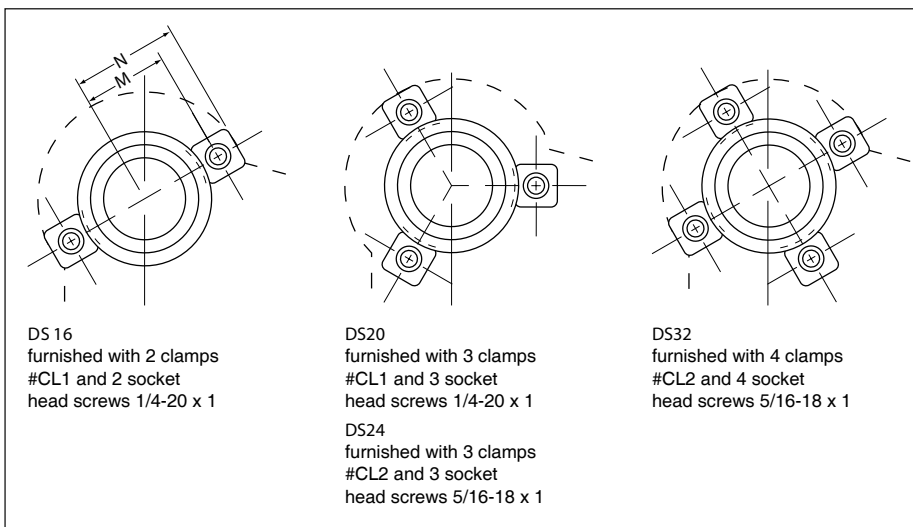
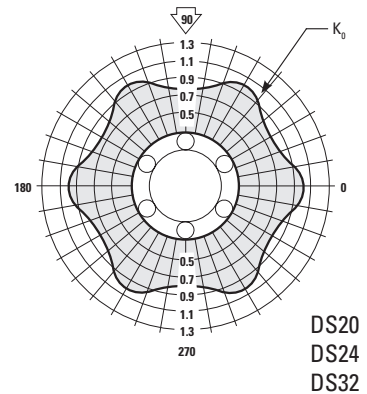
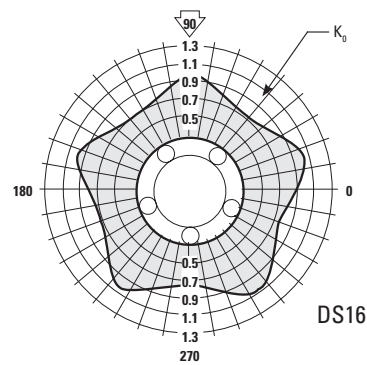

Die Set DS (Dimensions in Inches)			
Part Number		M	N
DS Ball Bushing Bearing	DS-B Ball Bushing Bearing		
DS16	DS16B	1.06	1.41
DS20	DS20B	1.27	1.61
DS24	DS24B	1.56	2.00
DS32	DS32B	1.94	2.38



# Part Number Description and Specification

## Precision Steel Ball Bushing® Bearings (Open Type) for Continuously Supported Applications

### OPN162536-SS

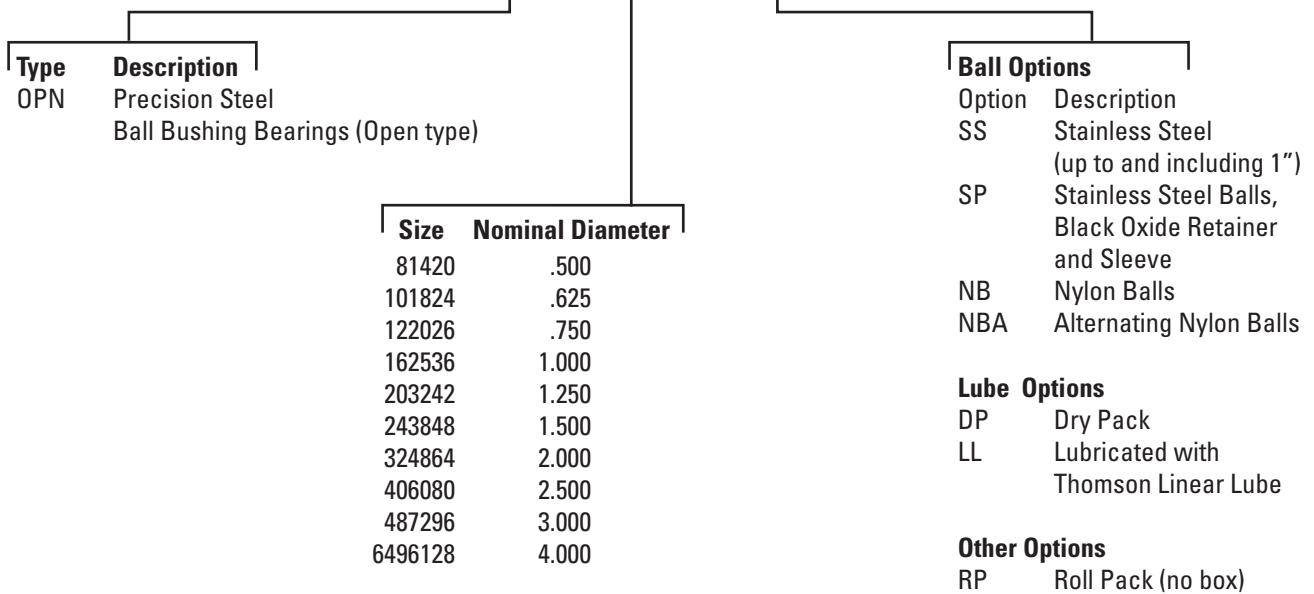

## Precision Steel Ball Bushing Pillow Blocks (Open Type) for Continuously Supported Applications

### PB080PN-SS

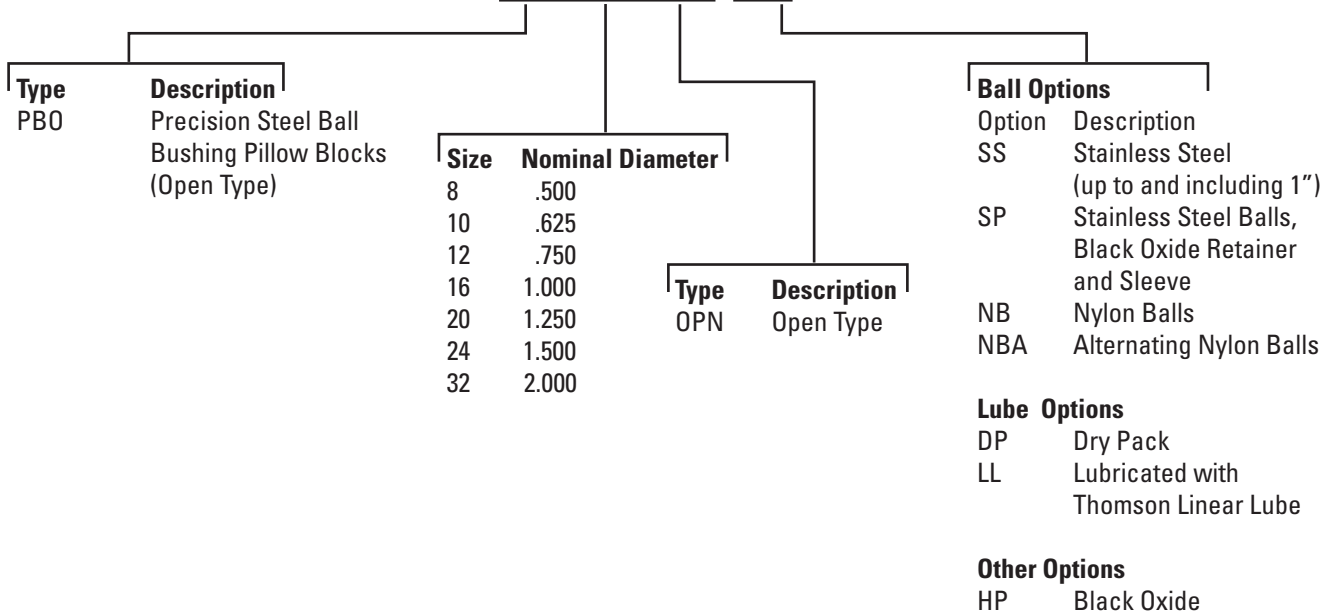

Not all options are available in all sizes.  
 See catalog pages or contact Thomson Customer Support for combination availability.  
 For additional information on bearing options, see page 267.

# Precision Steel Ball Bushing Bearings (Open Type) for Continuously Supported Applications

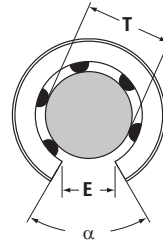
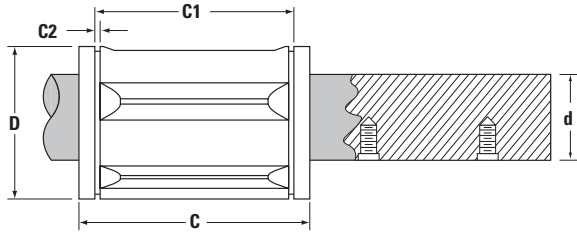
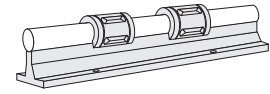

Sizes .500 thru 1.00 available in Corrosion resistant Stainless Steel.

**Precision Steel Ball Bushing Bearings (Open Type) and 60 Case® LinearRace®** (Dimensions in inches)

Part Number <sup>(1)</sup>		Nominal Diameter	Length C	Distance Between Retaining Rings C1	Ret. Ring Groove min. C2
Precision Steel Ball Bushing Bearing	60 Case LinearRace*				
OPN81420	1/2 L PD	.500	1.250/1.235	.967/.951	.046
OPN101824	5/8 L PD	.625	1.500/1.485	1.108/1.092	.056
OPN122026	3/4 L PD	.750	1.625/1.610	1.170/1.154	.056
OPN162536	1 L PD	1.000	2.250/2.235	1.759/1.741	.068
OPN203242	1 1/4 L PD	1.250	2.625/2.605	2.009/1.991	.068
OPN243848	1 1/2 L PD	1.500	3.000/2.980	2.415/2.397	.086
OPN324864	2 L PD	2.000	4.000/3.980	3.195/3.177	.103
OPN406080	2 1/2 L	2.500	5.000/4.975	3.978/3.958	.120
OPN487296	3 L	3.000	6.000/5.970	4.728/4.708	.120
OPN6496128	4 L	4.000	8.000/7.960	6.265/6.235	.139

\* 60 Case begins on page 176.

Part Number <sup>(1)</sup>	Working Bore Diameter T	Recommended Housing Bore Before Adjustment D	60 Case LinearRace Diameter d	Minimum Slot Width E	Angle deg alpha	Number of Ball Circuits	Ball Bushing Bearing Mass lb	Dynamic <sup>(2)</sup> Load Capacity lb <sub>i</sub>
OPN81420	.5005/.4995	.8760/.8740	.4995/.4990	.31	50	3	.07	60
OPN101824	.6255/.6245	1.1260/1.1240	.6245/.6240	.38	60	3	.11	105
OPN122026	.7505/.7495	1.2510/1.2490	.7495/.7490	.44	60	4	.17	140
OPN162536	1.0005/.9995	1.5635/1.5615	.9995/.9990	.56	60	4	.32	240
OPN203242	1.2506/1.2494	2.0010/1.9990	1.2495/1.2490	.63	50	5	.90	400
OPN243848	1.5006/1.4994	2.3760/2.3740	1.4994/1.4989	.75	50	5	1.12	600
OPN324864	2.0008/1.9992	3.0010/2.9990	1.9994/1.9987	1.00	50	5	2.16	860
OPN406080	2.5010/2.4990	3.7515/3.7485	2.4993/2.4985	1.25	50	5	4.24	1380
OPN487296	3.0012/2.9988	4.5015/4.4985	2.9992/2.9983	1.50	50	5	7.33	2000
OPN6496128	4.0020/3.9980	6.0020/5.9980	3.9988/3.9976	2.00	50	5	17.25	3800

(1) For part number description and specifications, see page 84.

(2) The Dynamic Load Capacity is based on a rated travel life of 2 million inches. The actual Dynamic Load Capacity can be affected by the orientation of the bearing or the direction of the applied load. For Dynamic Load Correction Factors, see following polar graphs.



## Load/Life Graph

(Lines indicate limiting load for given Ball Bushing® Bearing)

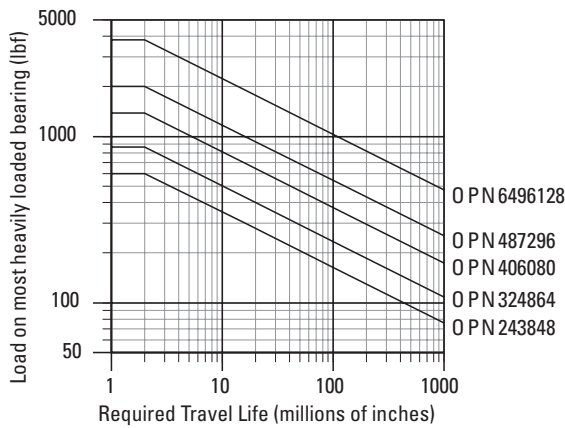
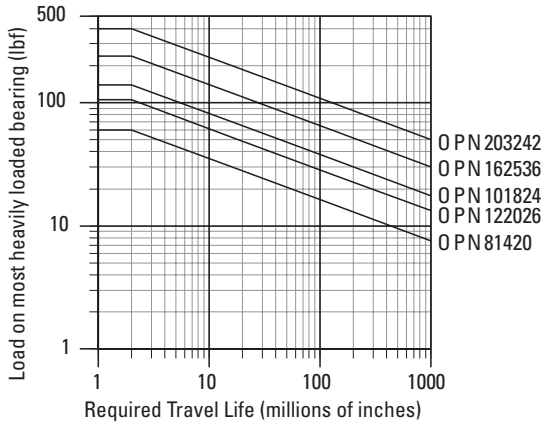

### Determining Ball Bushing Bearing Size

To determine the proper Ball Bushing Bearing size, enter the chart with the maximum load of the most heavily loaded bearing and the required travel life. Mark where the two lines intersect. All Ball Bushing Bearing sizes that pass through or above and to the right of this point may be suitable for this application.

**Note:** For the purpose of using this chart, load on most heavily loaded bearing = maximum applied load/ $K_0$ . Where  $K_0$  can be determined from the Polar Graph to the right.

## Polar Graphs

The actual dynamic load capacity of a Ball Bushing Bearing is determined by the orientation of the bearing or direction of the applied load. The load correction factor  $K_0$  is found by knowing the direction of the applied load relative to the orientation of the bearings ball tracks and referring to the polar graph. To determine the actual dynamic load capacity, multiply the proper correction factor by the dynamic load capacity listed in the product table on the previous page.

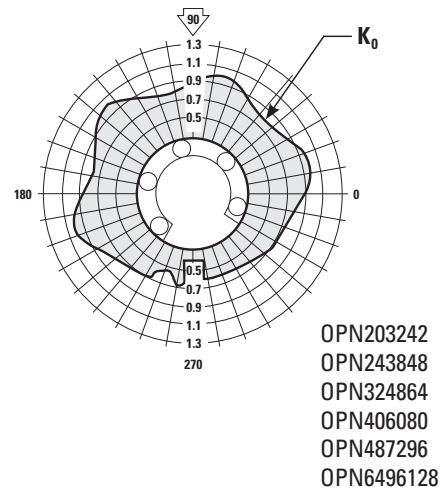
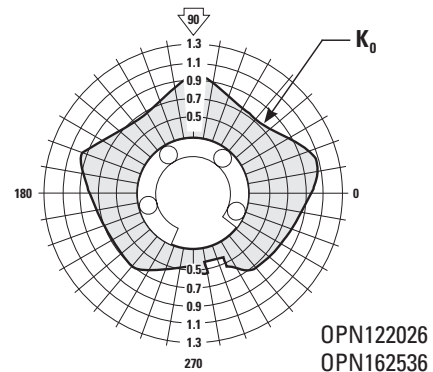
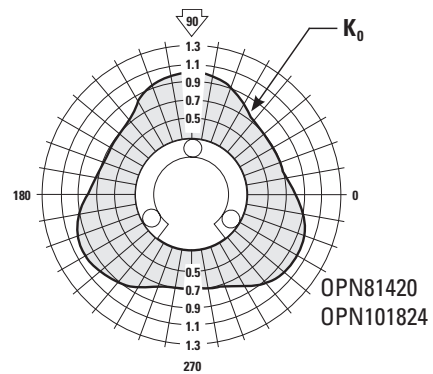

# Precision Steel Ball Bushing Bearing Pillow Block (Open Type) for Continuously Supported Applications

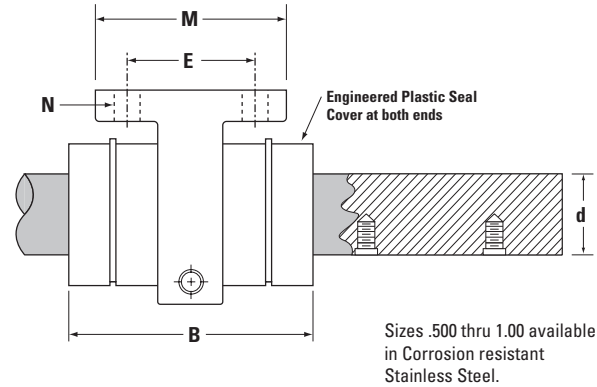
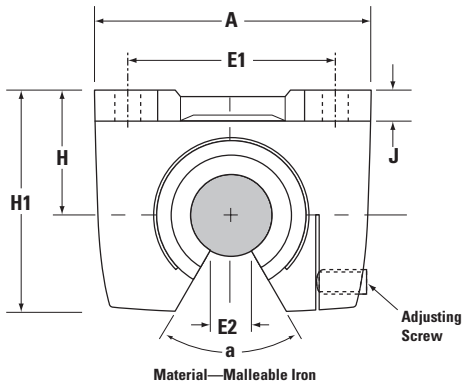
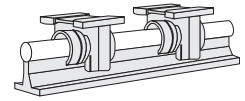

## Precision Steel Ball Bushing Bearing Pillow Blocks (Open Type, seal at both ends) and 60 Case® LinearRace® (Dim. in inches)

Part Number <sup>(1)</sup>		Nominal Diameter	H ±.005	H1
Precision Steel Ball Bushing Pillow Block	60 Case LinearRace*			
PB080PN	1/2 L PD	.500	.875	1.50
PB0120PN	3/4 L PD	.750	1.125	2.00
PB0160PN	1 L PD	1.000	1.375	2.38
PB0200PN	1 1/4 L PD	1.250	1.750	3.06
PB0240PN	1 1/2 L PD	1.500	2.000	3.50
PB0320PN	2 L PD	2.000	2.500	4.50

\* 60 Case begins on page 176.

Part Number <sup>(1)</sup>	60 Case LinearRace Diameter d	A	B	E ±.010	E1 ±.010	E2 min.	J	α deg	M	N		Pillow Block Weight lb	Dynamic <sup>(2)</sup> Load Capacity lb <sub>f</sub>
										Hole	Bolt		
PB080PN	.4995/.4990	2.00	1.69	1.000	1.500	.37	.25	50	1.50	.19	#8	.4	60
PB0120PN	.7495/.7490	2.75	2.06	1.375	2.000	.43	.31	60	2.00	.22	#10	1.0	140
PB0160PN	.9995/.9990	3.25	2.88	1.500	2.500	.56	.38	60	2.25	.28	1/4	1.8	240
PB0200PN	1.2495/1.2490	4.00	3.63	1.875	3.000	.67	.44	50	2.75	.34	5/16	3.8	400
PB0240PN	1.4994/1.4989	4.75	4.00	2.000	3.5000	.81	.50	50	3.00	.34	5/16	4.8	600
PB0320PN	1.9994/1.9987	6.00	5.00	2.500	4.500	1.00	.63	50	3.50	.41	3/8	8.5	860

(1) For part number description and specifications, see page 84.

(2) The Dynamic Load Capacity is based on a rated travel life of 2 million inches. The actual Dynamic Load Capacity can be affected by the orientation of the bearing or the direction of the applied load. For Dynamic Load Correction Factors, see following polar graphs.

Note: Check bearing clearance when using Thomson low support rail.



## Load/Life Graph

(Lines indicate limiting load for given Ball Bushing® Bearing)

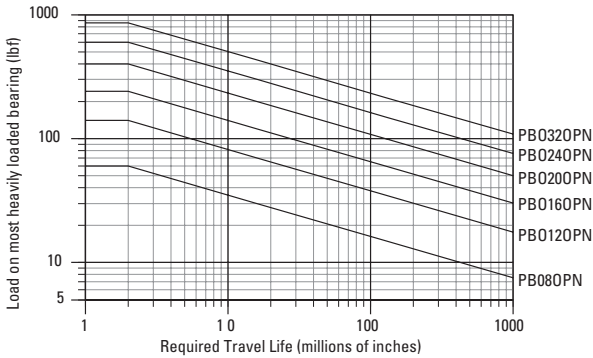

### Determining Ball Bushing Bearing Size

To determine the proper Ball Bushing Bearing size, enter the chart with the maximum load of the most heavily loaded bearing and the required travel life. Mark where the two lines intersect. All Ball Bushing Bearing sizes that pass through or above and to the right of this point may be suitable for this application.

**Note:** For the purpose of using this chart, load on most heavily loaded bearing = maximum applied load/ $K_0$ . Where  $K_0$  can be determined from the Polar Graph to the right.

## Polar Graphs

The actual dynamic load capacity of a Ball Bushing Bearing is determined by the orientation of the bearing or direction of the applied load. The load correction factor  $K_0$  is found by knowing the direction of the applied load relative to the orientation of the bearings ball tracks and referring to the polar graph. To determine the actual dynamic load capacity, multiply the proper correction factor by the dynamic load capacity listed in the product table on the previous page.

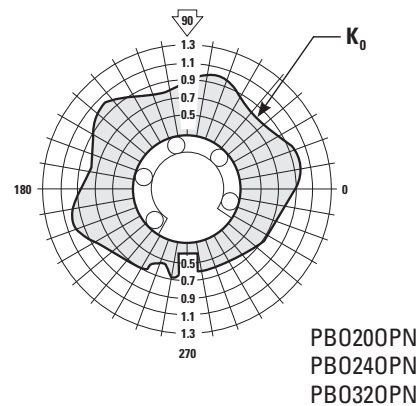
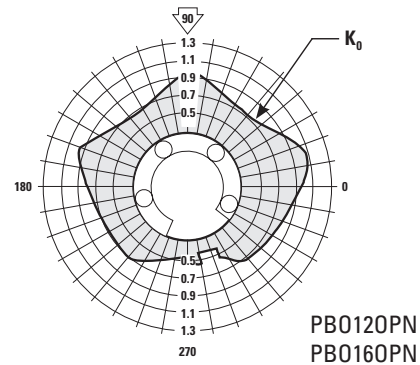
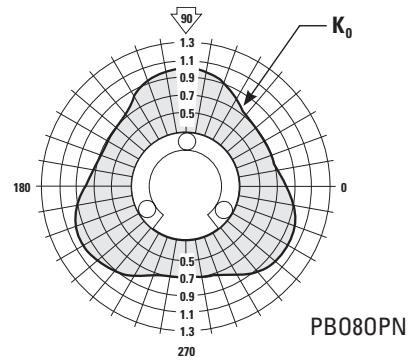

## Wire Straightening/Feeding Mechanism

### Objective

Redesign a wire straightening/feeding mechanism for a wire drawing machine that improves cycle time and minimizes downtime.

### Solution

Combine the performance advantages of the Precision Steel Ball Bushing Bearing with the operating efficiency of Thomson ball screws.

### Products Specified

- 4 - A162536 (Precision Steel Ball Bushing Bearings)
- 2 - 1 S CTL (60 Case® LinearRace®)
- 1 - .625 x .200 (Thomson ball screw assembly)

### Benefits

By replacing high-friction plain bearings with Precision Steel Ball Bushing Bearings, service life increased from six months to four years. This significantly reduced downtime and maintenance requirements and provided increased productivity.

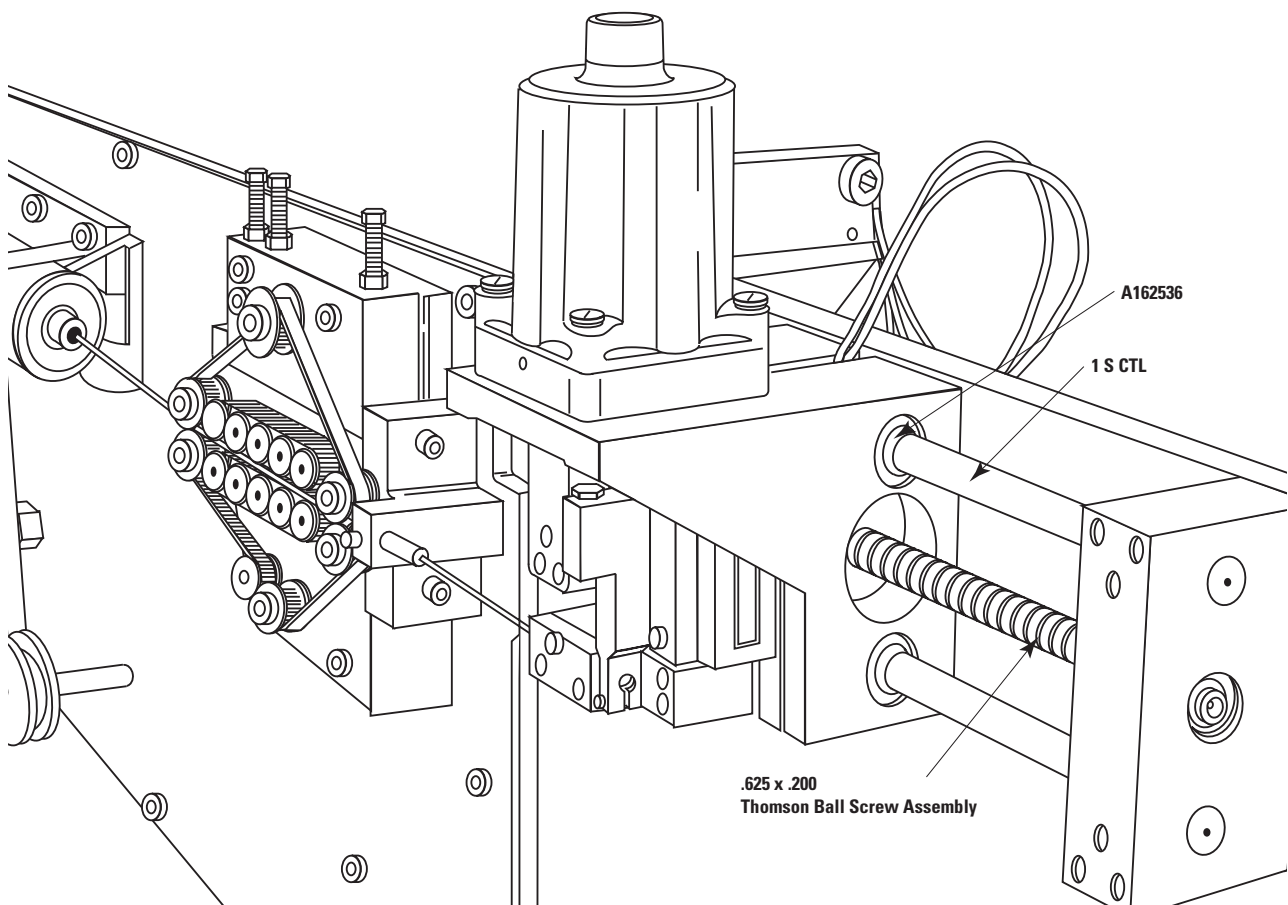



## XR Ball Bushing® Bearing Products

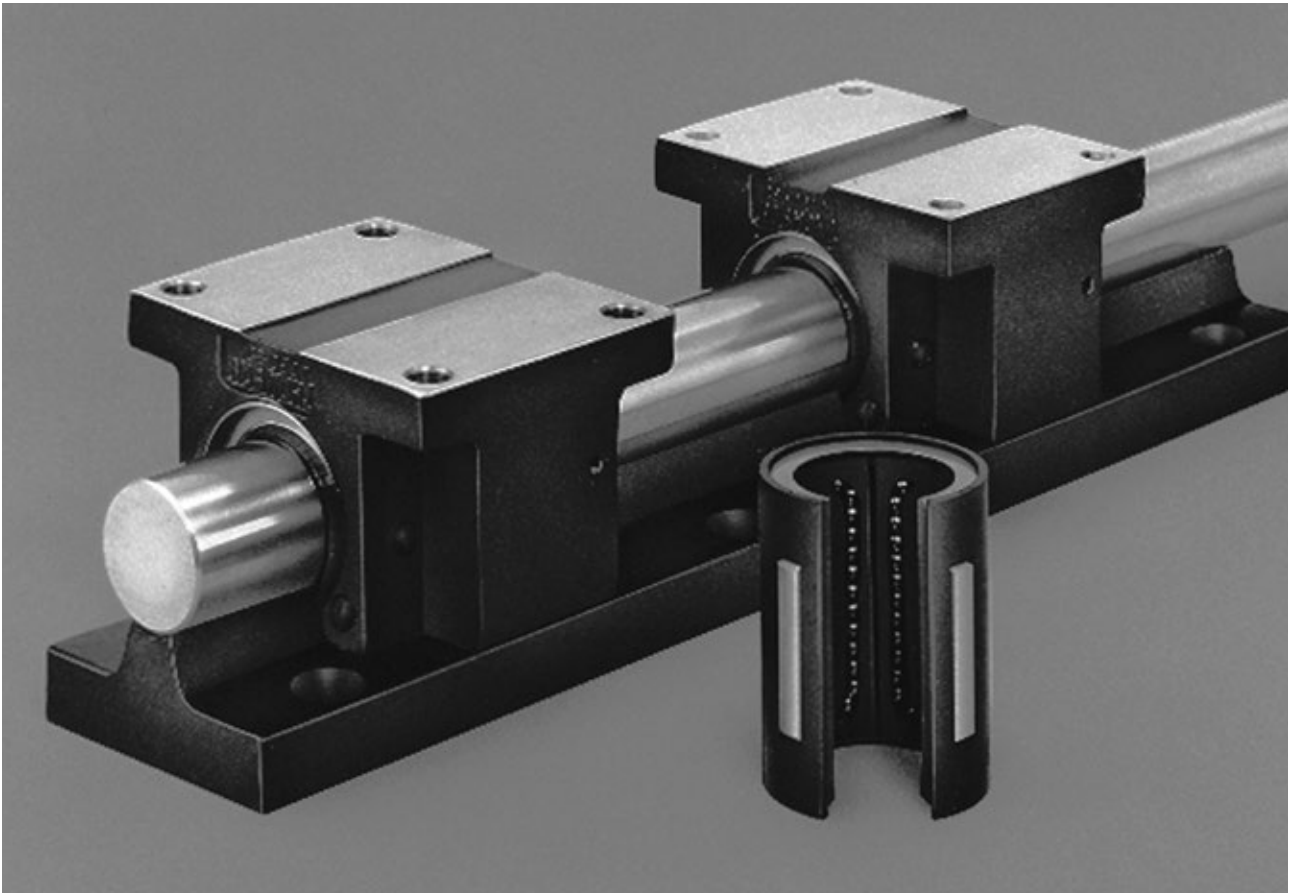

### Thomson XR Ball Bushing Bearing products offer:

- Five times the load capacity or 125 times the travel life of conventional linear bearings. This dramatic increase in travel life reduces downtime and maximizes productivity.
- Three times the rigidity of conventional linear bearings. This increase in stiffness provides immediate improvements in machine positioning accuracy and repeatability.
- The RoundRail Advantage combined with travel speeds up to 5 ft./s. Derating factors commonly found in linear guide products are eliminated.
- Ease of maintenance. When normal maintenance requires bearing replacement, XR Ball Bushing Bearings can be quickly and cost effectively replaced without scrapping the entire system – another shortcoming of some linear guides.
- Double-acting seals at both ends that keep out contamination and retain lubrication.
- Lasting precision alignment by combining the non-wear characteristics of the XR Ball Bushing Bearing with a rigid ductile iron pillow block.
- High accelerations and operating speeds without a dramatic increase in the power consumption commonly seen with high-friction v-way and flat-way systems.

XR Ball Bushing Bearing products provide five times the load capacity or 125 times the travel life and three times the rigidity of conventional linear bearings. These improvements are centered around four technologically advanced components: the XR Ball Bushing Bearing, the XPBO Ball Bushing pillow block, the XL 60 Case® LinearRace® (shaft) and the XSR 60 Case LinearRace support rail.

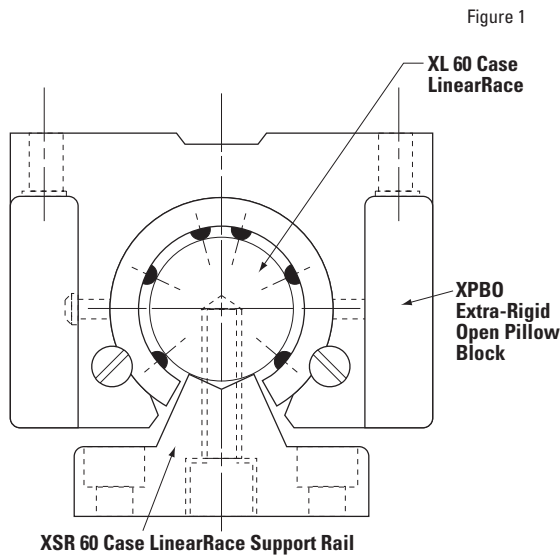

**XR Ball Bushing Bearing**

The dramatic increase in load capacity and/or travel life is provided by the XR Ball Bushing Bearing’s advanced plate design. Each ball-conforming bearing plate is precision ground, providing smooth and virtually friction-free linear movement. The bearing plate length has also been maximized to increase the number of rolling elements in the load carrying zone. The position of each XR bearing plate helps to maximize the load capacity in both pull-off and down-loading conditions.

**XPBO Ball Bushing Pillow Block**

Each XR Ball Bushing Bearing can be housed in a rigid ductile iron pillow block (Figure 1). The XPBO pillow block provides the stiffness required in high load applications (Figure 2). Each XPBO is equipped with four mounting holes for easy assembly to the table surface.

**XL 60 Case LinearRace**

Available factory mounted to XSR 60 Case LinearRace support rail is a hardened and precision-ground 60 Case LinearRace (Figure 1). Each 60 Case LinearRace is ground to a surface finish less than 10 Ra microinch and is straight to .001 inch per foot cumulative. Roundness of each 60 Case LinearRace is controlled through proprietary techniques that result in a roundness of 80 millionths of an inch. Each XL 60 Case LinearRace is held to these world-class quality standard to assure maximum system performance and travel life.

**XSR 60 Case LinearRace Support Rails**

Rigidity always starts by continuously supporting the 60 Case LinearRace and bearing system (Figure 1). The large ductile iron alloy cross-section of the XSR provides maximum rigidity and stiffness (Figure 2). The increased number of standard 60 Case LinearRace mounting holes add further stiffness and stability to the system.

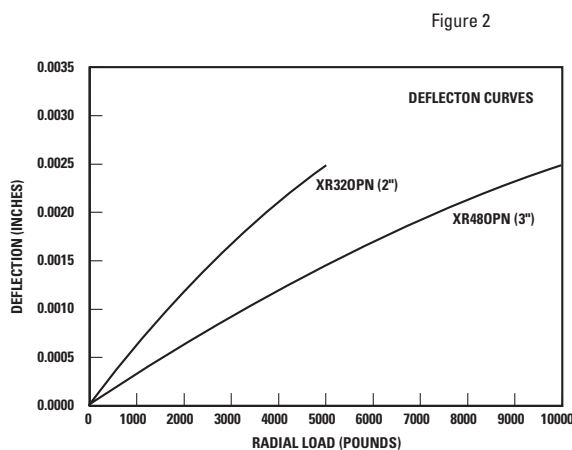

**The RoundRail Advantage**

The RoundRail Advantage is the inherent ability of an XR Ball Bushing Bearing system to accommodate torsional misalignment (caused by inaccuracies in carriage or base machining or by machine deflection) with little increase in stress-to-bearing components. Installation time and cost are minimized, and system performance is maximized.



# XR Ball Bushing® Bearings for Continuously Supported Applications

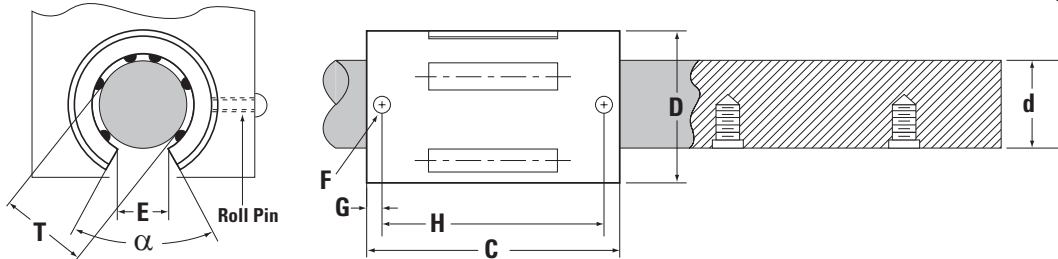
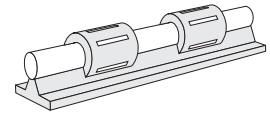

## XR Ball Bushing Bearings and 60 Case® LinearRace® (Dimensions in inches)

Part Number		Nom. Dia.	Length C	60 Case LinearRace Diameter d
XR Ball Bushing Bearing	60 Case LinearRace*			
XR320PN	2 XL PD	2	4.000/3.970	1.9994/1.9991
XR480PN	3 XL PD	3	6.000/5.940	2.9992/2.9989

\* 60 Case begins on page 176.

Part Number	Working Bore Diameter T	Recommended Housing Bore Diameter D	Minimum Slot Width E	Retention Hole <sup>(2)</sup>			Angle deg α	Number of Ball Circuits	Ball Diameter	Bearing Mass lb	Dynamic Load Capacity lb <sub>f</sub> <sup>(3)</sup>
				Diameter F	Loc. G	H					
XR320PN	2.0000/1.9992	3.0000	1.00	.27	.31	3.36	27	6	.25	1.3	4500
XR480PN	3.0000/2.9988	4.5000	1.50	.27	.42	5.145	30	6	.38	4.4	10000

(1) When installed in a nominal housing bore D, before adjustment. Any deviation from nominal housing bore diameter will change the working bore T, an equal amount. Minimum recommended housing bores are 2.9980 for XR320PN and 4.4975 for XR480PN.

(2) Retention hole does not go through bearing retainer.

(3) The Dynamic Load Capacity is based on a rated travel life of 2 million inches. The actual Dynamic Load Capacity can be affected by the orientation of the bearing or the direction of the applied load. For Dynamic Load Correction Factors, see following polar graphs.

### Load/Life Graph

(Lines indicate limiting load for given Ball Bushing Bearing)

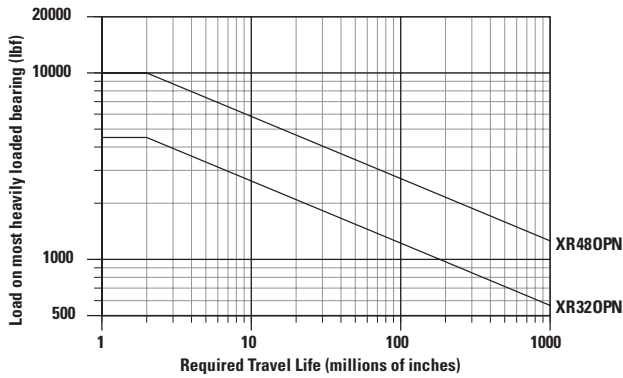

#### Determining Ball Bushing Bearing Size

To determine the proper Ball Bushing Bearing size, enter the chart with the maximum load of the most heavily loaded bearing and the required travel life. Mark where the two lines intersect. All Ball Bushing Bearing sizes that pass through or above and to the right of this point may be suitable for this application.

**Note:** For the purpose of using this chart, load on most heavily loaded bearing = maximum applied load/ $K_0$ . Where  $K_0$  can be determined from the Polar Graph to the right.

### Polar Graphs

The actual dynamic load capacity of a Ball Bushing Bearing is determined by the orientation of the bearing or direction of the applied load. The load correction factor  $K_0$  is found by knowing the direction of the applied load relative to the orientation of the bearings ball tracks and referring to the polar graph. To determine the actual dynamic load capacity, multiply the proper correction factor by the dynamic load capacity listed in the product table on the previous page.

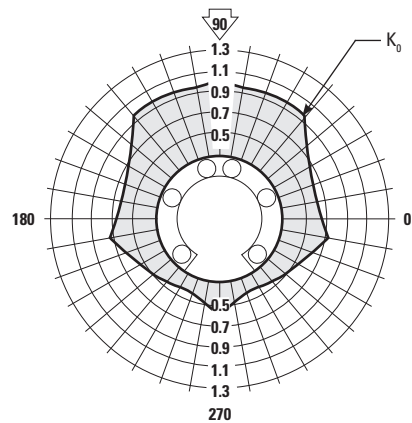



# XR Ball Bushing® Pillow Blocks for Continuously Supported Applications

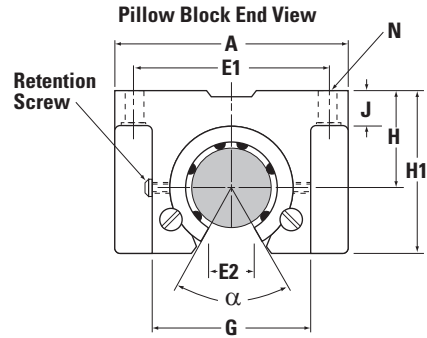
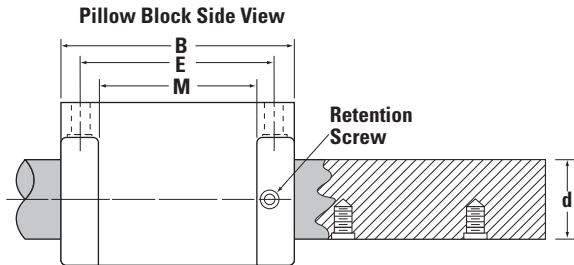
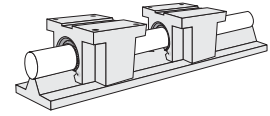

## XR Ball Bushing Pillow Blocks (seal at both ends) and 60 Case® LinearRace® (Dimensions in inches)

Part Number		Nominal Diameter	H +0.000 -0.001	H1
Extra Rigid Ball Bushing Bearing	60 Case LinearRace*			
XPB0320PN	2 XL PD	2	2.375	3.875
XPB0480PN	3 XL PD	3	3.500	5.875

\* 60 Case begins on page 176.

Part Number	Working Bore Diameter T	60 Case LinearRace Diameter d	Ball Bushing <sup>(1)</sup> Bearing/LinearRace Fit Up	A	B	E ±.010	E1 ±.010	E2 min.	G	J	$\alpha$ deg	M	N		Pillow Block Mass lb	Dynamic Load Capacity <sup>(2)</sup> lb <sub>f</sub>
XPB0320PN	1.9985/1.9972	1.9994/1.9991	.0022P/.006P	6.00	4.88	3.750	5.000	1.00	3.75	.88	27	2.63	.53	1/2	18	4500
XPB0480PN	2.9980/2.9963	2.9992/2.9989	.0029/.0009P	8.38	7.25	5.875	7.000	1.50	5.50	1.25	30	4.13	.66	5/8	55	10000

(1) XPBO pillow blocks are designed to give extra rigid support and are therefore dimensioned to provide the interference fits when used with

60 Case LinearRace class XL. If used with class L 60 Case LinearRace the fit-up values would be .0022P/.0002P for the 2 inch size and .0029P/.0003P for the 3 inch size.

(2) The Dynamic Load Capacity is based on a rated travel life of 2 million inches. The actual Dynamic Load Capacity can be affected by the orientation of the bearing or the direction of the applied load. For Dynamic Load Correction Factors, see following polar graphs.

### Load/Life Graph

(Lines indicate limiting load for given Ball Bushing Bearing)

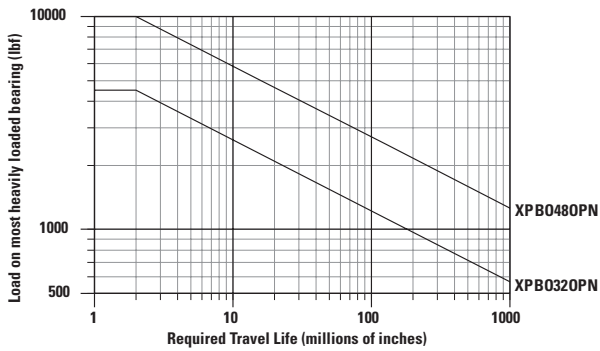

#### Determining Ball Bushing Bearing Size

To determine the proper Ball Bushing Bearing size, enter the chart with the maximum load of the most heavily loaded bearing and the required travel life. Mark where the two lines intersect. All Ball Bushing Bearing sizes that pass through or above and to the right of this point may be suitable for this application.

**Note:** For the purpose of using this chart, load on most heavily loaded bearing = maximum applied load/ $K_0$ . Where  $K_0$  can be determined from the Polar Graph to the right.

### Polar Graphs

The actual dynamic load capacity of a Ball Bushing Bearing is determined by the orientation of the bearing or direction of the applied load. The load correction factor  $K_0$  is found by knowing the direction of the applied load relative to the orientation of the bearings ball tracks and referring to the polar graph. To determine the actual dynamic load capacity, multiply the proper correction factor by the dynamic load capacity listed in the product table on the previous page.

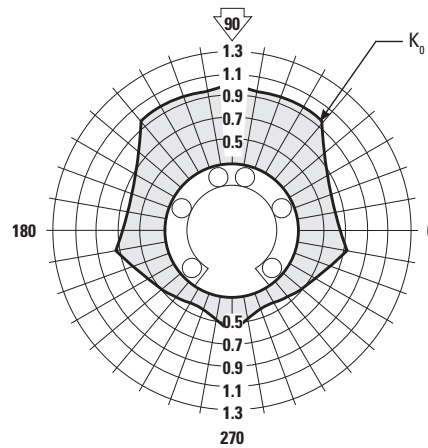



# X-Y-Z System

## Objective

Build a rigid X-Y-Z System designed to perform welding and flame-cutting tasks.

## Solution

Extra Rigid Ball Bushing® Bearings will be used on the X-axis to minimize deflection of the cantilevered Y-axis. Self-aligning Super Smart Ball Bushing Bearings are used on the Y and Z axis to simplify the assembly.

## Products Specified

### X-axis

- 4 - XR320PN (XR Ball Bushing Bearing)
- 2 - XSRA32 x 108 in (60 Case® LinearRace® support rail assembly)

### Y-axis

- 4 - SSU120PN (Super Smart Ball Bushing Bearing [Open Type])
- 2 - LSR-12-PD x 48 in (Low Profile 60 Case LinearRace Support Rail)
- 2 - 3/4 L PD CTL x 48 in (60 Case LinearRace)

### Z-axis

- 4 - SSU12 (Super Smart Ball Bushing Bearing)
- 2 - 3/4 L CTL x 36 in (60 Case LinearRace)

## Benefits

The high load capacity, rigidity and RoundRail Advantage of the Super Smart and XR Ball Bushing Bearings provided an easy to assemble system with a repeatability of  $\pm .005$  in.

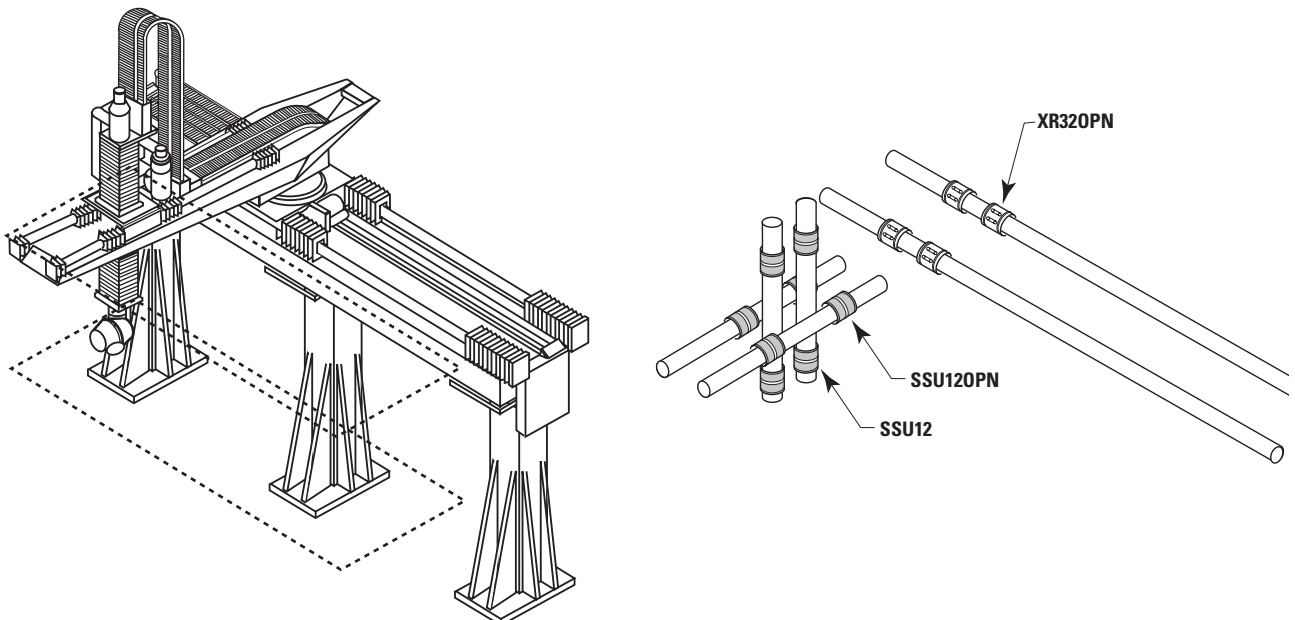

## RoundWay® Linear Roller Bearing Products



### Thomson RoundWay Linear Roller Bearings offer:

- Up to 20 times the load capacity of conventional linear ball bearings. This dramatic increase allows for more compact machine designs with a reduction in hardware costs.
- A rigid design that provides high accuracy while tolerating the high shock loads common to machine tool applications.
- A coefficient of friction as low as .005. When replacing v-ways or flat-ways, RoundWay linear roller bearings allow for the use of smaller, less expensive drives, motors, belts, gears and ball screws.
- A self-aligning capability that reduces installation time and cost.
- An eccentric trunnion pin that adjusts bearing height to compensate for minor inaccuracies in mounting base flatness or machining accuracy. Installation is quicker and easier than old style, conventional way systems.
- Availability of an integral wiper that protects against contamination while retaining lubrication.
- Interchangeable components for quick, cost-effective machine maintenance. There is no need to scrap the entire way system, a problem with some linear guide products.
- The RoundRail Advantage, combined with the self-aligning feature, eliminates the need for derating factors commonly seen with linear guides.

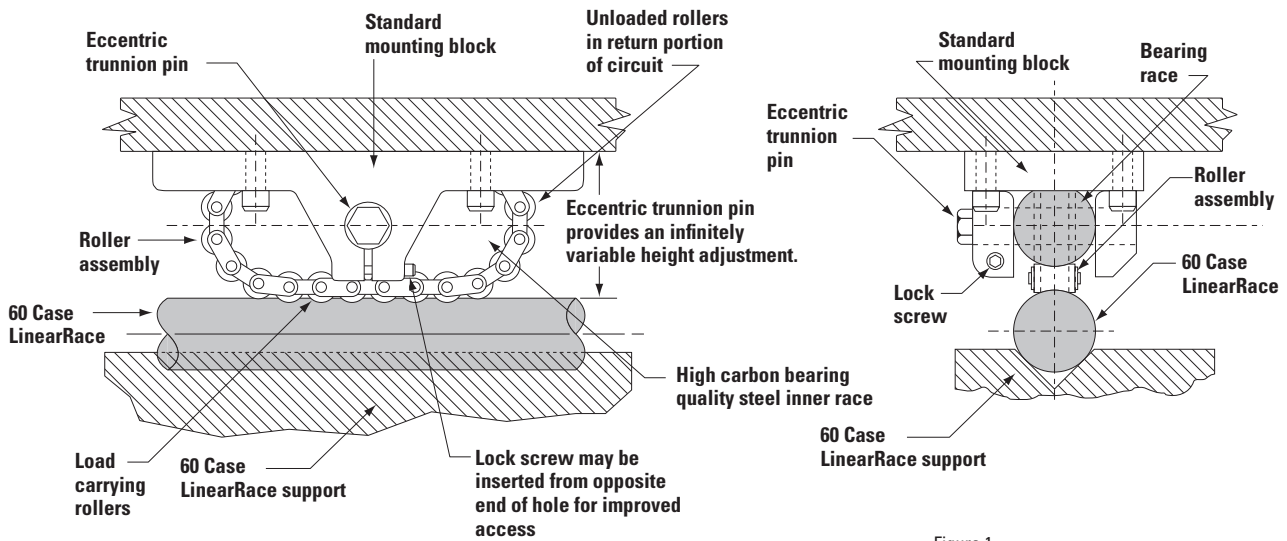

Figure 1  
RoundWay Operating Principle

Thomson invented the RoundWay® linear roller bearing for use in high-load, heavy duty applications. Each RoundWay bearing combines the high load capacity of hardened and ground steel recirculating rollers with a rigid, malleable iron pillow block, providing extremely high load capacity with smooth linear travel. The RoundWay linear roller bearing comes in both a single and dual version. A single RoundWay linear roller bearing does not resist side loads and is, therefore, always used in conjunction with a dual version, unless used in a configuration as shown in Figures 2, 3 and 4 on page 99.

Each RoundWay linear roller bearing is designed for use on 60 Case® LinearRace®. The 60 Case LinearRace shaft can be continuously supported using type LSR, SR or XSR 60 Case LinearRace support rails.

The RoundWay linear roller bearing consists of four basic parts: the bearing race, the roller assembly, the eccentric trunnion pin and the mounting block. The rolling elements of a RoundWay linear roller bearing are a series of concave rollers interconnected and linked by a chain assembly. As load is applied to the mounting block, it is transferred through the bearing race and roller assembly to the supported 60 Case LinearRace. Connecting the mounting block to the RoundWay bearing and roller assembly is an eccentric trunnion pin that allows the height of the RoundWay linear roller bearing to be adjusted to compensate for variations in the mounting surfaces or the buildup of tolerances between component elements. The eccentric trunnion pin can also be used to preload the RoundWay bearing by eliminating internal bearing clearance. After the eccentric trunnion pin has been adjusted, it can be held in place by simply tightening the lock screw.

### Self-Aligning

The RoundWay single and dual bearings are designed with a built-in, self-aligning capability that absorbs misalignment caused by inaccuracies in carriage or base machining. The RoundWay single bearing has an additional built-in, self-aligning capability that allows it to absorb misalignment caused by two slightly out-of-parallel 60 Case LinearRace ways. This feature is realized when two RoundWay single bearings are mounted on one 60 Case LinearRace, and two dual RoundWay bearings are on a parallel 60 Case LinearRace (Figure 1 on page 99).

# RoundWay Linear Roller Bearing Mounting

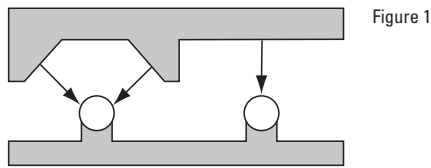

Figure 1

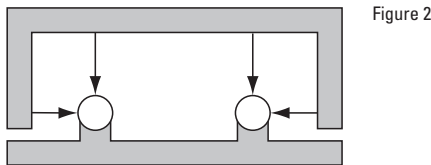

Figure 2

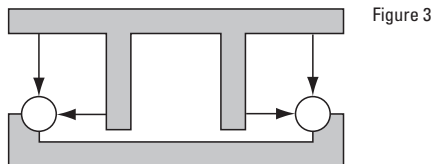

Figure 3

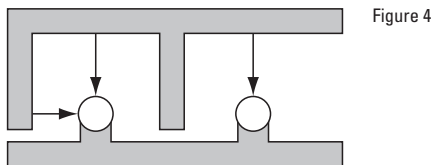

Figure 4

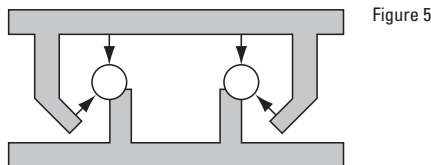

Figure 5

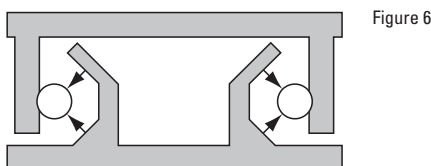

Figure 6

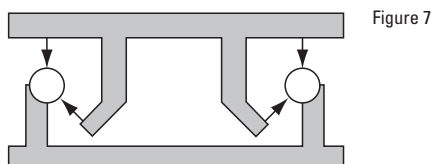

Figure 7

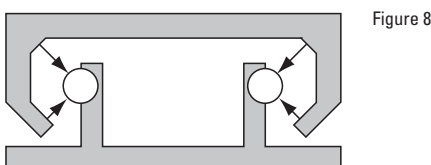

Figure 8

## Configurations

### RoundWay Bearing Mounting Arrangements

RoundWay bearings are available in single mounting blocks or dual V-blocks. The basic race and roller assembly can be purchased separately, along with the suitable type of trunnion pin for mounting directly in the carriage or other machine elements (see page 101). When using either type of cantilever mounting trunnion pin, deflection may be experienced under heavy loads.

The illustrations to the left are a few schematic suggestions for arrangements of RoundWay bearings and 60 Case LinearRace ways. The load directions of the bearings are indicated by arrows.

The first group (Figs. 1 through 4) depends on gravity to hold the carriage on the ways.

The second group shows arrangements that will carry loads in any direction. The first two figures (Figs. 5 and 6) are similar to the second two figures (Figs. 7 and 8), except for reverse orientation of horizontal, load-carrying bearings.

All schematics on this page can be pre-loaded except Fig. 1. In this arrangement, the maximum side load permitted is 50% of the applied vertical load on the Dual RoundWay bearing.

### IMPORTANT!

A single RoundWay bearing does not resist side loads. Therefore, dual RoundWay bearings or the equivalent are always used in combination with single units.



## RoundWay® Linear Roller Bearings for Continuously Supported Applications

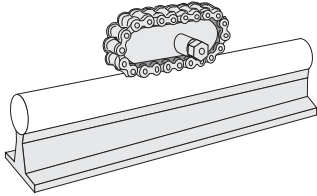

### RoundWay Linear Roller Bearing Type (Type A,B,C)

- Available in 1/2- through 4-inch diameters.
- Load capacity range between 970 and 24,000 lb<sub>f</sub>.
- Travel speeds up to 100 ft./s.
- Accelerations up to 450 ft./s<sup>2</sup>.
- Can be adjusted to compensate for variations in the mounting surface.
- Self aligning in all directions.
- Designed to compensate for two 60 Case® LinearRace® ways that are slightly out of parallel.
- Can be mounted in a custom housing.
- Available with a two-piece seal that retains lubrication while protecting the bearing from the ingress of dirt or contaminants.

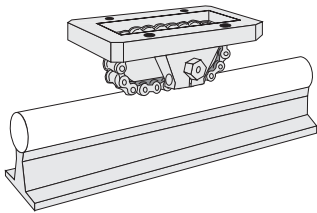

### RoundWay Linear Roller Bearing (Single Type S)

- Available in 1/2- through 4-inch diameters.
- Load capacity range between 970 and 24,000 lb<sub>f</sub>.
- Travel speeds up to 100 ft./s.
- Accelerations up to 450 ft./s<sup>2</sup>.
- Can be adjusted to compensate for variations in the mounting surface.
- Self aligning in all directions.
- Designed to compensate for two 60 Case LinearRace ways that are slightly out of parallel.
- Should always be used in conjunction with RoundWay Dual version.
- Can be mounted in a custom housing.
- Available with a two-piece seal that retains lubrication while protecting the bearing from the ingress of dirt or contaminants.
- Easily mounted to carriage with four mounting bolts.

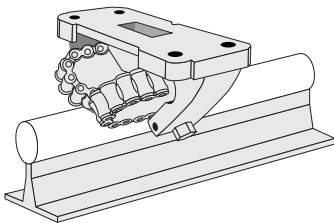

### RoundWay Linear Roller Bearing (Dual Type V)

- Available in 1/2- through 4-inch diameters.
- Load capacity range between 1370 and 35,000 lb<sub>f</sub>.
- Travel speeds up to 100 ft./s.
- Accelerations up to 450 ft./s<sup>2</sup>.
- Can be adjusted to compensate for variations in the mounting surface.
- Self aligning in all directions.
- Available with a two-piece seal that retains lubrication while protecting the bearing from the ingress of dirt or contaminants.
- Easily mounted to carriage with four mounting bolts.

# RoundWay Linear Roller Bearing Type A, B and C

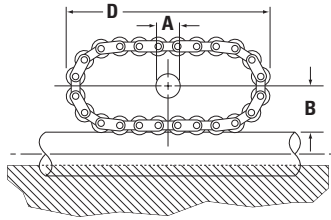

All trunnion pins make height of bearings infinitely adjustable within  $\pm .015"$  range except RW48A/B/C and RW64A/B/C, which are  $\pm .030"$ .

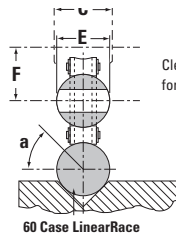

Clearance required for bearing

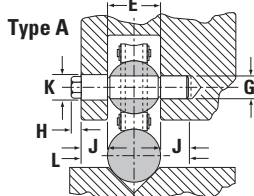
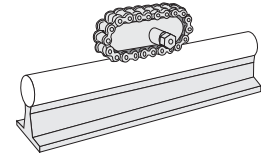

**Type A**  
If set screws are used to lock pin they should be at right angles to applied load  
Straddle Type Trunnion Pin

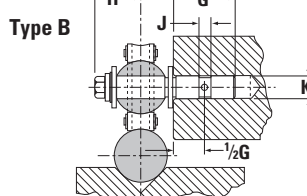

**Type B**  
If set screws are used to lock pin they should be at right angles to applied load  
Cantilever Type Trunnion Pin—Blind Hole

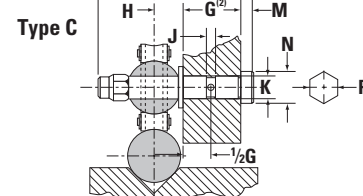

**Type C**  
If set screws are used to lock pin they should be at right angles to applied load  
Cantilever Type Trunnion Pin—Thru-hole

## RoundWay Linear Roller Bearing (Type A, B and C) and 60 Case LinearRace (Dimensions in inches)

Part Number				Nom. Dia.	A +.0005 -.0000	B	C	D	E $\pm .001$	F	$\alpha$ deg	60 Case LinearRace Diameter d	Dynamic (1) Load Capacity lb <sub>f</sub>
Bearing Type A	Bearing Type B	Bearing Type C	60 Case LinearRace										
RW8A	RW8B	RW8C	1/2 L PD	.500	.2500	.45	.63	2.38	.502	.56	50	.4995/.4990	970
RW16A	RW16B	RW16C	1 L PD	1.000	.4688	.80	1.00	3.75	1.002	.94	50	.9995/.9990	3020
RW24A	RW24B	RW24C	1 1/2 L PD	1.500	.7188	1.15	1.50	5.38	1.502	1.38	55	1.4994/1.4989	6020
RW32A	RW32B	RW32C	2 L PD	2.000	.9688	1.50	2.00	7.38	2.002	1.75	55	1.9994/1.9987	12360
RW48A	RW48B	RW48C	3 L PD	3.000	1.5626	2.30	3.00	11.00	3.002	2.75	50	2.9992/2.9983	24000
RW64A	RW64B	RW64C	4 L PD	4.000	2.0626	3.00	4.00	14.88	4.002	3.50	50	3.9988/3.9976	48000

### Trunnion Type A

Round-Way Bearing Part Number	G +.0000 -.0005	H	J	K +.0000 -.0005	L	Bearing Mass lb
RW8A	.2187	.19	.31	.2812	1.13	.30
RW16A	.4375	.25	.50	.5000	2.00	1.10
RW24A	.6875	.31	.63	.7500	2.75	3.10
RW32A	.9375	.38	.75	1.0000	3.50	7.3
RW48A	1.5000	.59	1.25	1.6250	5.53	24.0
RW64A	2.0000	.72	1.50	2.1250	7.03	58.0

### Trunnion Type B

Round-Way Bearing Part Number	G	H	J	K +.000 -.001	L	Bearing Mass lb
RW8B	.75	.31	.13	.3105	1.63	.30
RW16B	1.25	.59	.19	.498	2.78	1.10
RW24B	1.75	.88	.25	.748	3.94	3.10
RW32B	2.25	1.13	.31	.998	5.06	7.70
RW48B	3.50	1.75	.50	1.623	8.00	24.80
RW64B	4.00	2.25	.50	2.123	9.75	61.60

### Trunnion Type C

Round-Way Bearing Part Number	G <sup>(2)</sup> +.060 -.000	H	J	K +.000 -.001	L	M	N	P Std. Hex across Flats	Bearing Mass lb
RW8C	.719	.31	.13	.311	1.69	.22	.44	—	.30
RW16C	1.188	.59	.19	.498	2.88	.31	.75	—	1.10
RW24C	1.656	.88	.25	.748	4.13	.50	1.00	—	3.20
RW32C	2.094	1.13	.31	.998	5.25	.63	1.31	—	7.90
RW48C	3.063	1.75	.50	1.623	7.25	1.00	—	2.25	25.60
RW64C	4.063	2.25	.50	2.123	9.38	1.63	—	3.00	63.20

(1) Dynamic Load Capacity is based on 10 million inches of travel.

(2) Thickness of mounting member.

Note: For RoundWay replacement parts, see page 130.

## Load/Life Graph (Lines indicate limiting load for given RoundWay bearing)

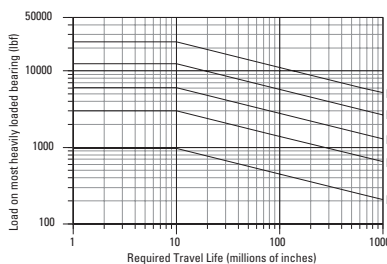

### Determining RoundWay Bearing Size

The primary factors that influence the choice of bearing size are maximum load on a single RoundWay bearing and the required travel life. To determine the proper RoundWay bearing size, enter the chart with the maximum load of the most heavily loaded bearing and the required travel life. Mark where the two lines intersect. All RoundWay bearing sizes that pass through or above and to the right of this point may be suitable for this application.



# RoundWay® Linear Roller Bearing (Single Type)

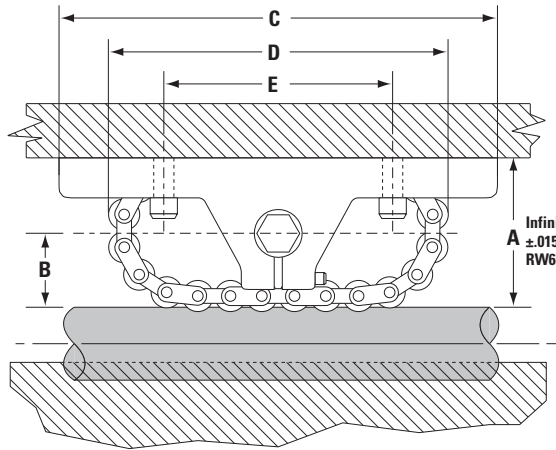

A Infinitely adjustable within  $\pm .015"$  range except RW48S and RW64S, which are  $\pm .030"$ .

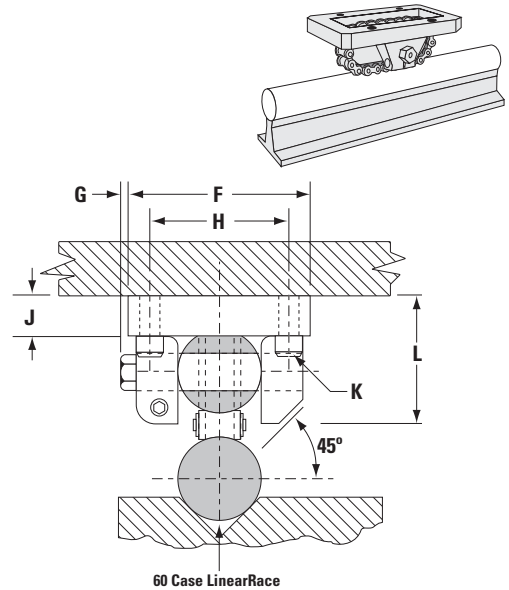

## RoundWay Linear Roller Bearing (Single Type) and 60 Case® LinearRace® (Dimensions in inches)

Part Number		Nom. Dia.	A	B	C	D	E	F	G	H	J	K		L	60 Case LinearRace Diameter d	Bearing Mass lb	Dynamic Load Capacity lb <sub>1</sub>
RoundWay Bearing	60 Case LinearRace											Bolt	Hole				
RW8S	1/2 L PD	.500	1.00	.45	3.0	2.38	1.50	1.25	.19	.94	.31	#6	.16	.88	.4995/.4990	.50	970
RW16S	1 L PD	1.000	1.75	.80	5.0	3.75	2.50	2.13	.25	1.63	.50	#10	.25	1.50	.9995/.9990	2.20	3020
RW24S	1 1/2 L PD	1.500	2.50	1.15	6.5	5.38	3.50	2.88	.31	2.13	.63	5/16	.38	2.13	1.4994/1.4989	5.60	6020
RW32S	2 L PD	2.000	3.25	1.50	8.5	7.38	4.50	3.63	.38	2.75	.75	3/8	.44	2.88	1.9994/1.9987	12.40	12360
RW48S	3 L PD	3.000	5.00	2.30	13.0	11.00	7.00	6.00	.50	4.25	1.25	5/8	.69	4.25	2.9992/2.9983	48.00	24000
RW64S	4 L PD	4.000	6.50	3.00	17.0	14.88	9.00	7.75	.50	5.50	1.50	3/4	.81	5.88	3.9988/3.9976	105.00	48000

(1) Dynamic Load Capacity is based on 10 million inches of travel.  
Note: For RoundWay replacement parts, see page 130.

## Load/Life Graph (Lines indicate limiting load for given RoundWay bearing)

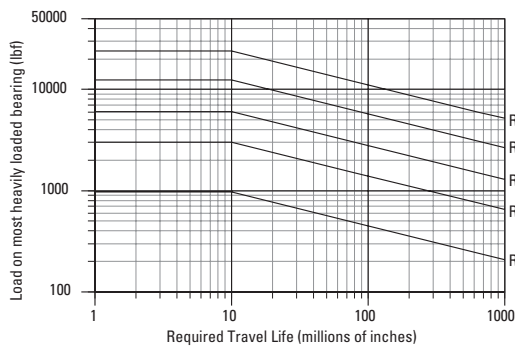

### Determining RoundWay Bearing Size

The primary factors that influence the choice of bearing size are maximum load on a single RoundWay bearing and the required travel life. To determine the proper RoundWay bearing size, enter the chart with the maximum load of the most heavily loaded bearing and the required travel life. Mark where the two lines intersect. All RoundWay bearing sizes that pass through or above and to the right of this point may be suitable for this application.

# RoundWay Linear Roller Bearing (Dual Type)

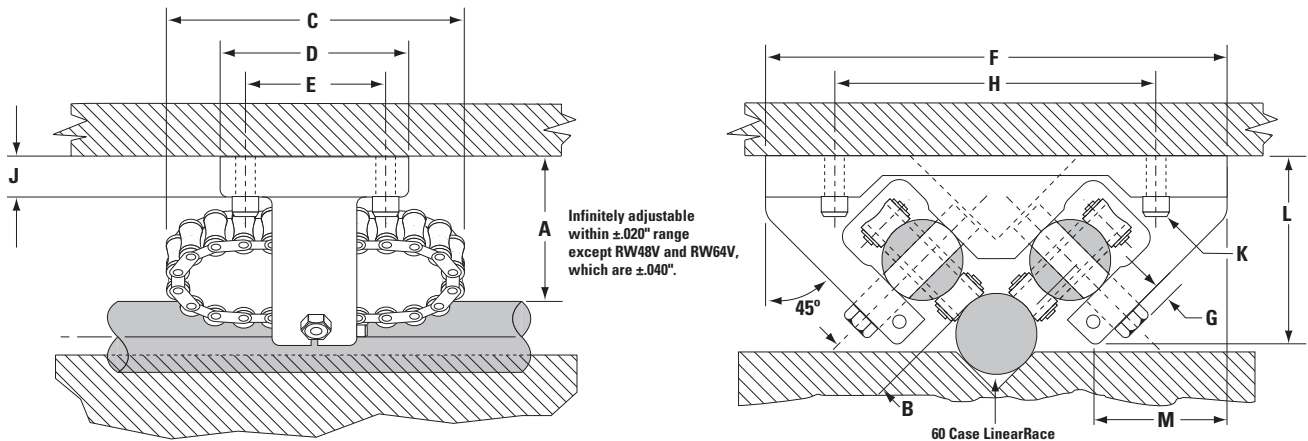
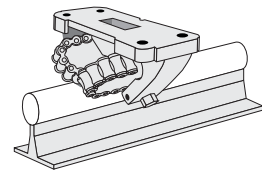

**RoundWay Linear Roller Bearing (Dual Type) and 60 Case LinearRace** (Dimensions in inches)

Part Number		Nom. Dia.	A	B	C	D	E	F	G	H	J	K		L	M	60 Case LinearRace Diameter d	Bearing Mass lb	Dynamic <sup>(1)</sup> Load Capacity lb <sub>f</sub>
RoundWay Bearing	60 Case LinearRace											Bolt	Hole					
RW8V	1/2 L PD	.500	1.00	.45	2.38	1.38	1.00	3.00	.19	2.25	.31	#8	.19	1.38	.69	.4995/.4990	1.10	1370
RW16V	1 L PD	1.000	1.75	.80	3.75	2.25	1.63	5.75	.25	4.0	.50	#10	.25	2.38	1.56	.9995/.9990	4.90	4300
RW24V	1 1/2 L PD	1.500	2.50	1.15	5.38	2.75	2.00	7.88	.31	6.0	.63	5/16	.38	3.38	2.13	1.4994/1.4989	11.70	8600
RW32V	2 L PD	2.000	3.25	1.50	7.38	3.50	2.50	9.75	.38	7.5	.75	3/8	.44	4.33	2.50	1.9994/1.9987	25.20	17500
RW48V	3 L PD	3.000	5.00	2.30	11.00	5.50	4.00	15.50	.63	12	1.25	5/8	.69	6.69	4.25	2.9992/2.9983	90.00	35000
RW64V	4 L PD	4.000	6.50	3.00	14.88	7.00	5.00	19.25	.75	15	1.50	3/4	.81	8.63	5.00	3.9988/3.9976	193.00	70000

(1) Dynamic Load Capacity is based on 10 million inches of travel.  
 Note: For RoundWay replacement parts, see page 130.

## Load/Life Graph (Lines indicate limiting load for given RoundWay bearing)

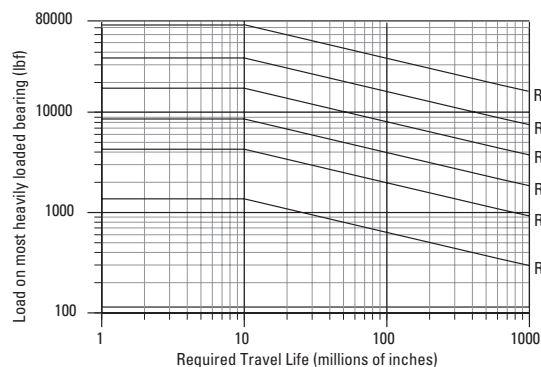

### Determining RoundWay Bearing Size

The primary factors that influence the choice of bearing size are maximum load on a single RoundWay bearing and the required travel life. To determine the proper RoundWay bearing size, enter the chart with the maximum load of the most heavily loaded bearing and the required travel life. Mark where the two lines intersect. All RoundWay bearing sizes that pass through or above and to the right of this point may be suitable for this application.



# Overhead Carriage for Log-Processing Machine

## Objective

Design overhead carriage system using RoundWay® linear roller bearings mounted on 60 Case® LinearRace® ways.

## Solution

RoundWay linear roller bearings' high load capacity will be used to move heavy logs into and out of the band saws. The carriages shuttle back and forth on 100-foot-long 60 Case LinearRace ways until the final cut is made.

## Products specified

- 2 - RW32V (RoundWay Linear Roller bearing Dual Type)
- 2 - RW32S (RoundWay Linear Roller bearing Single Type)
- 2 - 2 L PD CTL x 100 ft (60 Case LinearRace)

## Benefits

RoundWay linear roller bearings provide operating speeds up to 100 ft./s, optimizing productivity and minimizing cost. The RoundWay bearings' low coefficient of friction allows the use of smaller, less expensive drive motors, belts, linkages and gears. The seal keeps out wood chips and other contaminants and maximizes bearing life.

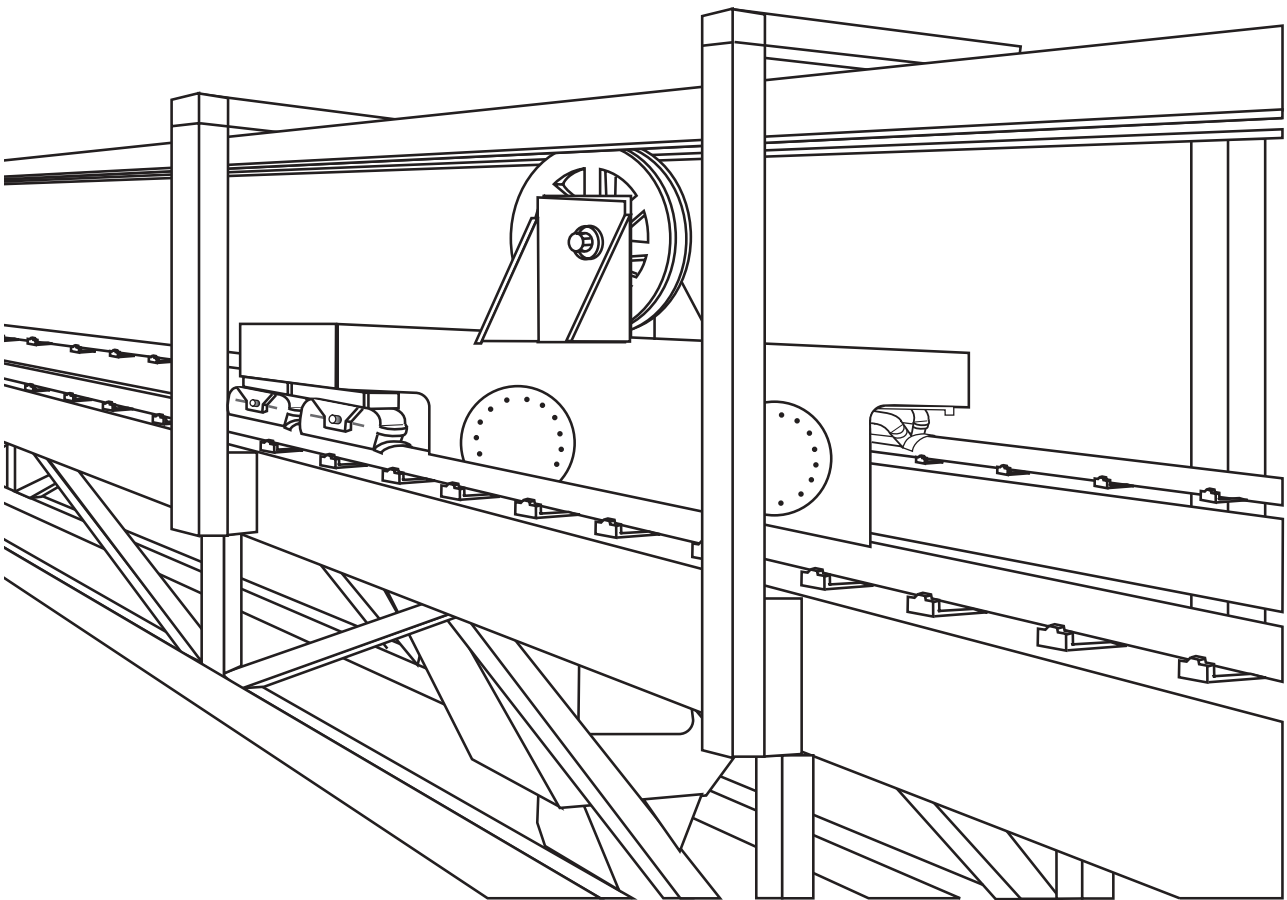

## FluoroNyliner® Bushing Bearings



### Thomson FluoroNyliner Bushing Bearings offer:

- High performance in contaminated, washdown or submerged environments.
- Proprietary, self-lubricating, composite bearing liner TEP 950.
- Low friction, ideally suited for linear and rotary motion.
- Precision-machined aluminum sleeve.
- Excellent performance in high-vibration and mechanical shock applications.
- Corrosion resistance.
- Product availability in industry standard sizes from 0.25" to 2.00".
- Eight bearing configurations, include closed, open, self-aligning, precision and compensated IDs.
- Load capacities up to 14,000 lb<sub>r</sub>.
- Closed, open, and flanged pillow blocks available in single or twin versions.
- Available from distributors worldwide.



# FluoroNyliner<sup>®</sup> Bushing Bearings

## Common Specifications

Nominal Bearing Diameter (in.)	60 Case LinearRace Shafting			Recommended Shaft Diameter (in.) <sup>(1)</sup>		Weight (lbs.)	Effective Surface Area (in <sup>2</sup> )	Max. Static Load (lb.) <sup>(2)</sup>
	Carbon Steel	316 Stainless Steel	Aluminum	Min.	Max.			
.250	1/4 L	1/4 L SS316	1/4 AL	.2490	.2495	.008	.19	300
.375	3/8 L	3/8 L SS316	3/8 AL	.3740	.3745	.013	.33	500
.500	1/2 L	1/2 L SS316	1/2 AL	.4990	.4995	.030	.63	970
.625	5/8 L	5/8 L SS316	5/8 AL	.6240	.6245	.072	.94	1450
.750	3/4 L	3/4 L SS316	3/4 AL	.7490	.7495	.090	1.22	1900
1.000	1 L	1 L SS316	1 AL	.9990	.9995	.190	2.25	3500
1.250	1 1/4 L	1 1/4 L SS316	-	1.2490	1.2495	.380	3.28	5100
1.500	1 1/2 L	1 1/2 L SS316	-	1.4989	1.4994	.610	4.51	7000
2.000	2 L	2 L SS316	-	1.9987	1.9994	1.230	8.01	12500

(1) Shown are Carbon Steel and 316 Stainless Steel Class L Diameter Tolerance.

(2) Open bearings operating in shear should be derated by 40%. Open bearings operating in tension should be derated by 70%.

## Closed Bearing

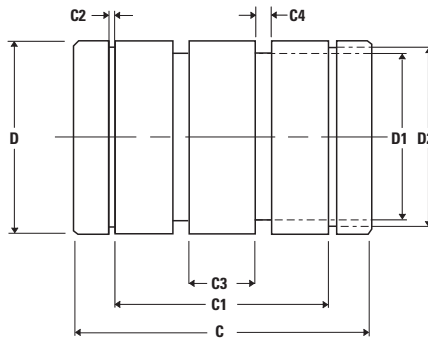

Side View

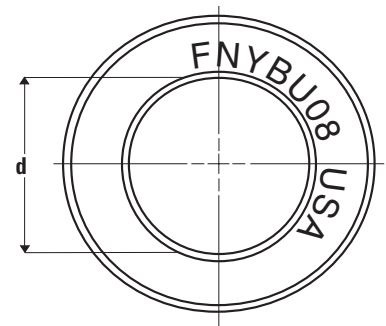

Front View

## Self-Aligning Bearing

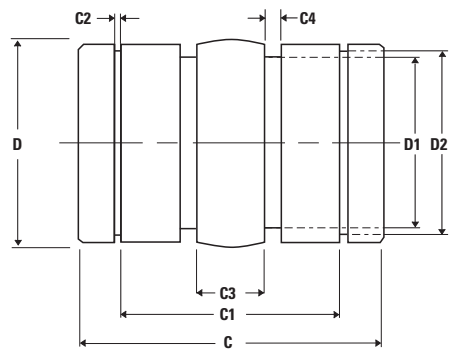

Side View



### Standard Bearings

Precision I.D.			Compensated I.D. <sup>1</sup>				Closed Bearing Dimensions (in.)									
Part Number	d (in.)		Part Number	d (in.)		Nom. Bearing Dia.	D		D1	D2	C		C1 Min.	C2 Min.	C3	C4
	Min.	Max.		Min.	Max.		Min.	Max.			Min.	Max.				
FNYBU04	0.2505	0.2515	FNYBU04L	0.2530	0.2540	0.250	0.4990	0.5000	0.395	0.467	0.735	0.750	0.437	0.040	0.180	0.085
FNYBU06	0.3755	0.3765	FNYBU06L	0.3780	0.3780	0.375	0.6240	0.6250	0.520	0.587	0.860	0.875	0.562	0.040	0.260	0.085
FNYBU08	0.5005	0.5015	FNYBU08L	0.5030	0.5040	0.500	0.8740	0.8750	0.710	0.820	1.235	1.250	0.875	0.048	0.490	0.118
FNYBU10	0.6255	0.6265	FNYBU10L	0.6280	0.6290	0.629	1.1240	1.1250	0.958	1.060	1.485	1.500	1.000	0.058	0.550	0.118
FNYBU12	0.7508	0.7518	FNYBU12L	0.7540	0.7550	0.750	1.2490	1.2500	1.085	1.175	1.610	1.625	1.062	0.058	0.612	0.118
FNYBU16	1.0008	1.0018	FNYBU16L	1.0040	1.0050	1.000	1.5615	1.5625	1.395	1.467	2.235	2.250	1.625	0.070	1.180	0.118
FNYBU20	1.2508	1.2518	FNYBU20L	1.2550	1.2560	1.250	1.9990	2.0000	1.835	1.885	2.610	2.625	1.875	0.070	1.425	0.118
FNYBU24	1.5008	1.5002	FNYBU24L	1.5050	1.5062	1.500	2.3735	2.3750	2.210	2.238	2.980	3.000	2.250	0.090	1.670	0.118
FNYBU32	2.0012	2.0027	FNYBU32L	2.0050	2.0074	2.000	2.9985	3.0000	2.750	2.837	3.980	4.000	3.000	0.105	1.450	0.155

### Standard Self-Aligning Bearings

Precision I.D.			Compensated I.D. <sup>1</sup>				Closed Bearing Dimensions (in.)									
Part Number	d (in.)		Part Number	d (in.)		Nom. Bearing Dia.	D		D1	D2	C		C1 Min.	C2 Min.	C3	C4
	Min.	Max.		Min.	Max.		Min.	Max.			Min.	Max.				
FNYBU04A	0.2505	0.2515	FNYBU04AL	0.2530	0.2540	0.250	0.4990	0.5000	0.395	0.467	0.735	0.750	0.437	0.040	0.180	0.085
FNYBU06A	0.3755	0.3765	FNYBU06AL	0.3780	0.3780	0.375	0.6240	0.6250	0.520	0.587	0.860	0.875	0.562	0.040	0.260	0.085
FNYBU08A	0.5005	0.5015	FNYBU08AL	0.5030	0.5040	0.500	0.8740	0.8750	0.710	0.820	1.235	1.250	0.875	0.048	0.490	0.118
FNYBU10A	0.6255	0.6265	FNYBU10AL	0.6280	0.6290	0.629	1.1240	1.1250	0.958	1.060	1.485	1.500	1.000	0.058	0.550	0.118
FNYBU12A	0.7508	0.7518	FNYBU12AL	0.7540	0.7550	0.750	1.2490	1.2500	1.085	1.175	1.610	1.625	1.062	0.058	0.612	0.118
FNYBU16A	1.0008	1.0018	FNYBU16AL	1.0040	1.0050	1.000	1.5615	1.5625	1.395	1.467	2.235	2.250	1.625	0.070	1.180	0.118
FNYBU20A	1.2508	1.2518	FNYBU20AL	1.2550	1.2560	1.250	1.9990	2.0000	1.835	1.885	2.610	2.625	1.875	0.070	1.425	0.118
FNYBU24A	1.5008	1.5002	FNYBU24AL	1.5050	1.5062	1.500	2.3735	2.3750	2.210	2.238	2.980	3.000	2.250	0.090	1.670	0.118
FNYBU32A	2.0012	2.0027	FNYBU32AL	2.0050	2.0074	2.000	2.9985	3.0000	2.750	2.837	3.980	4.000	3.000	0.105	1.450	0.155

<sup>1</sup> Compensated I.D. bearings have additional running clearance, ideally suited for high speed and non-parallel shaft applications.



### Common Open Bearing Dimensions (in.)

Nominal Bearing Diameter (in.)	E	F	G	B	a
.250	.094	.375	.125	.188	60
.375	.094	.438	.146	.250	60
.500	.136	.625	.000	.313	66
.625	.104	.125	.000	.375	60
.750	.136	.125	.000	.438	66
1.000	.136	.125	.000	.563	64
1.250	.201	.197	.000	.625	60
1.500	.201	.193	.000	.750	60
2.000	.265	.292	.000	1.000	60

### Open Bearing

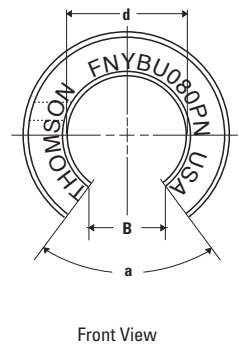
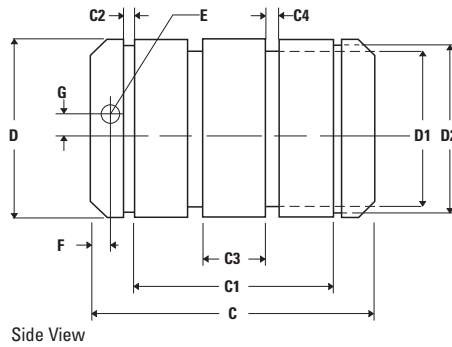
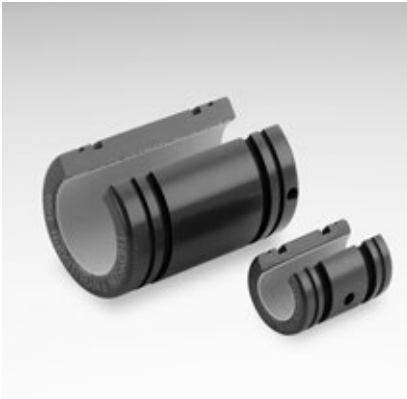

### Self-Aligning Open Bearing

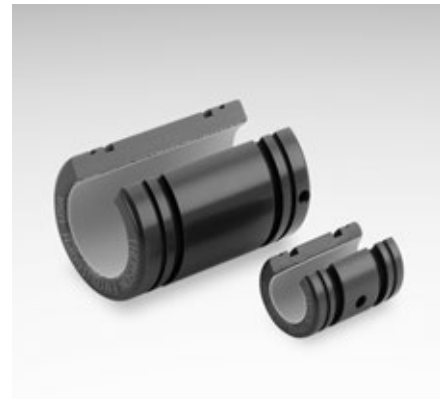
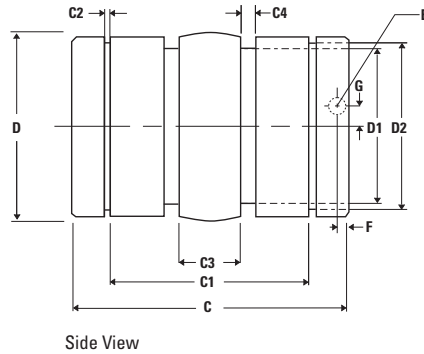
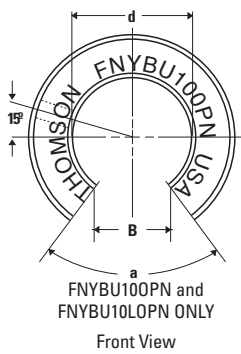

**Standard Open Bearings**

Precision I.D.		Compensated I.D. <sup>1</sup>				Open Bearing Dimensions (in.)										
Part Number	d (in.)		Part Number	d (in.)		Nom. Bearing Dia.	D		D1	D2	C		C1 Min.	C2 Min.	C3	C4
	Min.	Max.		Min.	Max.		Min.	Max.			Min.	Max.				
FNYBU04OPN	0.2505	0.2515	FNYBU04LOPN	0.2530	0.2540	0.250	0.4990	0.5000	0.395	0.467	0.735	0.750	0.437	0.040	0.180	0.085
FNYBU06OPN	0.3755	0.3765	FNYBU06LOPN	0.3780	0.3780	0.375	0.6240	0.6250	0.520	0.587	0.860	0.875	0.562	0.040	0.260	0.085
FNYBU08OPN	0.5005	0.5015	FNYBU08LOPN	0.5030	0.5040	0.500	0.8740	0.8750	0.710	0.820	1.235	1.250	0.875	0.048	0.490	0.118
FNYBU10OPN	0.6255	0.6265	FNYBU10LOPN	0.6280	0.6290	0.629	1.1240	1.1250	0.958	1.060	1.485	1.500	1.000	0.058	0.550	0.118
FNYBU12OPN	0.7508	0.7518	FNYBU12LOPN	0.7540	0.7550	0.750	1.2490	1.2500	1.085	1.175	1.610	1.625	1.062	0.058	0.612	0.118
FNYBU16OPN	1.0008	1.0018	FNYBU16LOPN	1.0040	1.0050	1.000	1.5615	1.5625	1.395	1.467	2.235	2.250	1.625	0.070	1.180	0.118
FNYBU20OPN	1.2508	1.2518	FNYBU20LOPN	1.2550	1.2560	1.250	1.9990	2.0000	1.835	1.885	2.610	2.625	1.875	0.070	1.425	0.118
FNYBU24OPN	1.5008	1.5002	FNYBU24LOPN	1.5050	1.5062	1.500	2.3735	2.3750	2.210	2.238	2.980	3.000	2.250	0.090	1.670	0.118
FNYBU32OPN	2.0012	2.0027	FNYBU32LOPN	2.0050	2.0074	2.000	2.9985	3.0000	2.750	2.837	3.980	4.000	3.000	0.105	1.450	0.155

**Standard Self-Aligning Open Bearings**

Precision I.D.		Compensated I.D. <sup>1</sup>				Self-Aligning Bearing Dimensions (in.)										
Part Number	d (in.)		Part Number	d (in.)		Nom. Bearing Dia.	D		D1	D2	C		C1 Min.	C2 Min.	C3	C4
	Min.	Max.		Min.	Max.		Min.	Max.			Min.	Max.				
FNYBU04AOPN	0.2505	0.2515	FNYBU04ALOPN	0.2530	0.2540	0.250	0.4990	0.5000	0.395	0.467	0.735	0.750	0.437	0.040	0.180	0.085
FNYBU06AOPN	0.3755	0.3765	FNYBU06ALOPN	0.3780	0.3780	0.375	0.6240	0.6250	0.520	0.587	0.860	0.875	0.562	0.040	0.260	0.085
FNYBU08AOPN	0.5005	0.5015	FNYBU08ALOPN	0.5030	0.5040	0.500	0.8740	0.8750	0.710	0.820	1.235	1.250	0.875	0.048	0.490	0.118
FNYBU10AOPN	0.6255	0.6265	FNYBU10ALOPN	0.6280	0.6290	0.629	1.1240	1.1250	0.958	1.060	1.485	1.500	1.000	0.058	0.550	0.118
FNYBU12AOPN	0.7508	0.7518	FNYBU12ALOPN	0.7540	0.7550	0.750	1.2490	1.2500	1.085	1.175	1.610	1.625	1.062	0.058	0.612	0.118
FNYBU16AOPN	1.0008	1.0018	FNYBU16ALOPN	1.0040	1.0050	1.000	1.5615	1.5625	1.395	1.467	2.235	2.250	1.625	0.070	1.180	0.118
FNYBU20AOPN	1.2508	1.2518	FNYBU20ALOPN	1.2550	1.2560	1.250	1.9990	2.0000	1.835	1.885	2.610	2.625	1.875	0.070	1.425	0.118
FNYBU24AOPN	1.5008	1.5002	FNYBU24ALOPN	1.5050	1.5062	1.500	2.3735	2.3750	2.210	2.238	2.980	3.000	2.250	0.090	1.670	0.118
FNYBU32AOPN	2.0012	2.0027	FNYBU32ALOPN	2.0050	2.0074	2.000	2.9985	3.0000	2.750	2.837	3.980	4.000	3.000	0.105	1.450	0.155

<sup>1</sup> Compensated I.D. bearings have additional running clearance, ideally suited for high speed and non-parallel shaft applications.



## FluoroNyliner® Bushing Bearing Pillow Blocks



For the easiest installation, order pillow blocks with factory installed FluoroNyliner Bushing Bearings.

### Three Pillow Block Configurations



#### Closed Bearing Pillow Blocks

- For end-supported applications.
- Choose twin pillow blocks for twice the load capacity.
- Order with seals for heavily contaminated environments.
- Available as single or twin pillow blocks.



#### Open Bearing Pillow Blocks

- For continuously supported applications.
- Choose compensated I.D. bearings for non-parallel shafting.
- Order with seals for heavily contaminated environments.
- Available as single or twin pillow blocks.



#### Flanged Pillow Blocks with Closed Bearings

- For low-profile applications such as packaging equipment.
- Choose precision I.D. bearings for precision fit-up.
- Available with self-aligning or compensated I.D. bearings.
- Available as single or twin pillow blocks.

**Closed Pillow Blocks with Self-Aligning Bearings**

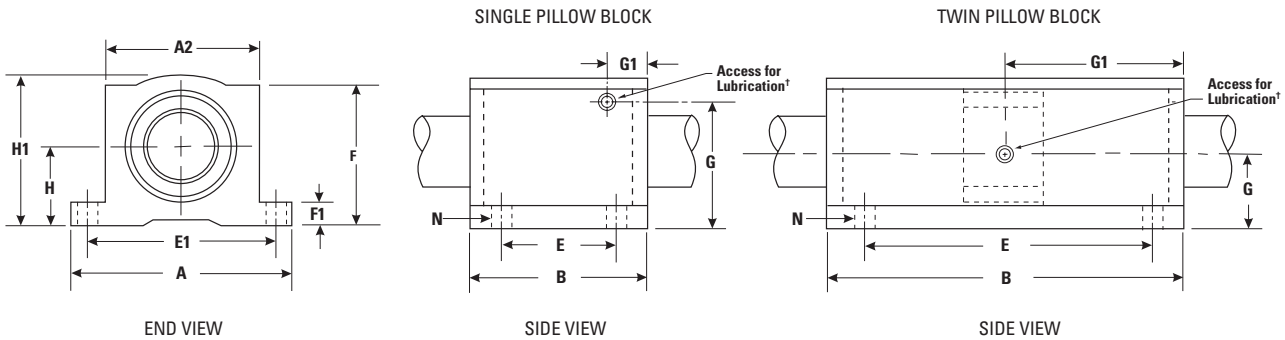

† Sizes .25, .375 and .500 have oil lubricant fitting. Sizes .625 and above have 1/4-28 access for lubrication.

**Closed Single Pillow Blocks with Self-Aligning Bearings**

Precision I.D.		Compensated I.D. <sup>1</sup>		Single Pillow Block Dimensions (in.)													Pillow Block Mass (lb)	Max. Static Load (lb <sub>r</sub> )
Part Number	Part Number	H ±.003	H1	A	A2	B	E ±.010	E1 ±.010	F	F1	G	G1	N					
													Hole	Bolt				
FNYBUPB04ALS	FNYBUPB04ALLS	.437	.81	1.63	1.00	1.19	.750	1.313	.75	.19	.60	.41	.16	#6	.10	300		
FNYBUPB06ALS	FNYBUPB06ALLS	.500	.94	1.75	1.13	1.31	.875	1.438	.88	.19	.70	.41	.16	#6	.13	500		
FNYBUPB08ALS	FNYBUPB08ALLS	.687	1.25	2.00	1.38	1.69	1.000	1.688	1.13	.25	.97	.44	.16	#6	.40	970		
FNYBUPB10ALS	FNYBUPB10ALLS	.875	1.63	2.50	1.75	1.94	1.125	2.125	1.44	.28	1.17	.68	.19	#8	1.00	1450		
FNYBUPB12ALS	FNYBUPB12ALLS	.937	1.75	2.75	1.88	2.06	1.250	2.375	1.56	.31	.94	.72	.19	#8	1.20	1900		
FNYBUPB16ALS	FNYBUPB16ALLS	1.187	2.19	3.25	2.38	2.81	1.750	2.875	1.94	.38	1.20	.86	.22	#10	2.40	3500		
FNYBUPB20ALS	FNYBUPB20ALLS	1.500	2.81	4.00	3.00	3.63	2.000	3.500	2.50	.44	1.50	1.20	.22	#10	5.00	5100		
FNYBUPB24ALS	FNYBUPB24ALLS	1.750	3.25	4.75	3.50	4.00	2.500	4.125	2.88	.50	1.75	1.25	.28	1/4	7.80	7000		
FNYBUPB32ALS	FNYBUPB32ALLS	2.125	4.06	6.00	4.50	5.00	3.250	5.250	3.63	.63	1.30	1.25	.41	3/8	7.80	12500		

**Closed Twin Pillow Blocks with Self-Aligning Bearings**

Precision I.D.		Compensated I.D. <sup>1</sup>		Twin Pillow Block Dimensions (in.)													Pillow Block Mass (lb)	Max. Static Load (lb <sub>r</sub> )
Part Number	Part Number	H ±.003	H1	A	A2	B	E ±.010	E1 ±.010	F	F1	G	G1	N					
													Hole	Bolt				
FNYBUTWN04ALS	FNYBUTWN04ALLS	.437	.81	1.63	1.00	2.50	2.000	1.313	.75	.19	.60	.41	.16	#6	.19	600		
FNYBUTWN06ALS	FNYBUTWN06ALLS	.500	.94	1.75	1.13	2.75	2.250	1.438	.88	.19	.70	.41	.16	#6	.25	1000		
FNYBUTWN08ALS	FNYBUTWN08ALLS	.687	1.25	2.00	1.38	3.50	2.500	1.688	1.13	.25	.97	.44	.16	#6	.40	1940		
FNYBUTWN10ALS	FNYBUTWN10ALLS	.875	1.63	2.50	1.75	4.00	3.000	2.125	1.44	.28	1.17	.68	.19	#8	1.00	2900		
FNYBUTWN12ALS	FNYBUTWN12ALLS	.937	1.75	2.75	1.88	4.50	3.500	2.375	1.56	.31	.94	.72	.19	#8	1.20	3800		
FNYBUTWN16ALS	FNYBUTWN16ALLS	1.187	2.19	3.25	2.38	6.00	4.500	2.875	1.94	.38	1.20	.86	.22	#10	2.40	7000		
FNYBUTWN20ALS	FNYBUTWN20ALLS	1.500	2.81	4.00	3.00	7.50	5.500	3.500	2.50	.44	1.50	1.20	.22	#10	5.00	10200		
FNYBUTWN24ALS	FNYBUTWN24ALLS	1.750	3.25	4.75	3.50	9.00	6.500	4.125	2.88	.50	1.75	1.25	.28	1/4	7.80	14000		

<sup>1</sup> Compensated I.D. bearings have additional running clearance, ideally suited for high-speed and non-parallel shaft applications. Note: For pillow block seals or non-self-aligning bearings, see Part Number Matrix on page 113.



## Open Pillow Blocks with Self-Aligning Bearings

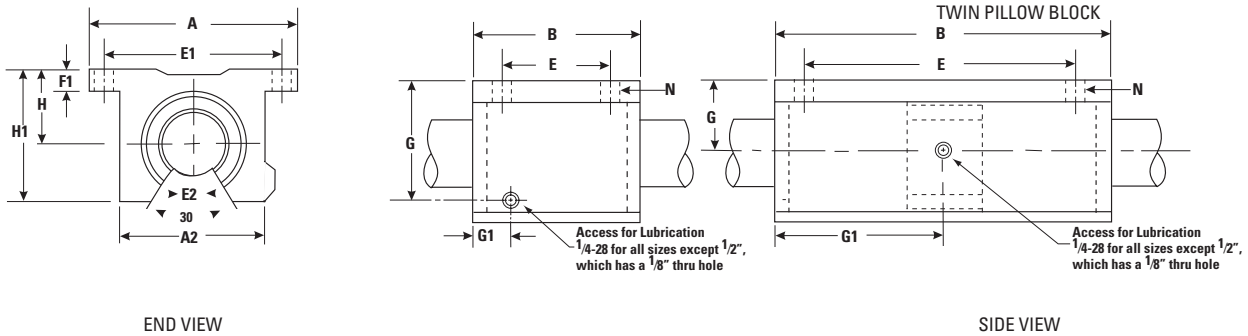

## Open Single Pillow Blocks with Self-Aligning Bearings

Precision I.D.		Compensated I.D. <sup>1</sup>		Single Pillow Block Dimensions (in.)												Pillow Block Mass (lb)	Max. Static Load (lb.) <sup>(2)</sup>
Part Number	Part Number	H ±.003	H1	A	A2	B	E ±.010	E1 ±.010	F1	G	G1	N					
												Hole	Bolt				
FNYBUPB008ALS	FNYBUPB008ALLS	.687	1.13	2.00	1.38	1.50	1.000	1.688	.25	.69	.84	.16	#6	.20	970		
FNYBUPB010ALS	FNYBUPB010ALLS	.875	1.44	2.50	1.75	1.75	1.125	2.125	.28	.70	.68	.19	#8	.50	1450		
FNYBUPB012ALS	FNYBUPB012ALLS	.937	1.56	2.75	1.88	1.88	1.250	2.375	.31	.94	.72	.19	#8	.60	1900		
FNYBUPB016ALS	FNYBUPB016ALLS	1.187	2.00	3.25	2.38	2.63	1.750	2.875	.38	1.20	.86	.22	#10	1.20	3500		
FNYBUPB020ALS	FNYBUPB020ALLS	1.500	2.50	4.00	3.00	3.38	2.000	3.500	.44	1.50	1.20	.22	#10	2.50	5100		
FNYBUPB024ALS	FNYBUPB024ALLS	1.750	2.94	4.75	3.50	3.75	2.500	4.125	.50	1.75	1.25	.28	1/4	3.80	7000		
FNYBUPB032ALS	FNYBUPB032ALLS	2.125	3.63	6.00	4.50	4.75	3.250	5.250	.63	2.12	1.58	.41	3/8	7.00	12500		

## Open Twin Pillow Blocks with Self-Aligning Bearings

Precision I.D.		Compensated I.D. <sup>1</sup>		Twin Pillow Block Dimensions (in.)												Pillow Block Mass (lb)	Max. Static Load (lb.) <sup>(2)</sup>
Part Number	Part Number	H ±.003	H1	A	A2	B	E ±.010	E1 ±.010	F1	G	G1	N					
												Hole	Bolt				
FNYBUTWN008ALS	FNYBUTWN008ALLS	.687	1.13	2.00	1.38	3.50	2.500	1.688	.25	.59	1.75	.16	#6	.40	1940		
FNYBUTWN010ALS	FNYBUTWN010ALLS	.875	1.44	2.50	1.75	4.00	3.000	2.125	.28	.85	2.00	.19	#8	1.00	2900		
FNYBUTWN012ALS	FNYBUTWN012ALLS	.937	1.56	2.75	1.88	4.50	3.500	2.375	.31	.94	2.25	.19	#8	1.20	3800		
FNYBUTWN016ALS	FNYBUTWN016ALLS	1.187	2.00	3.25	2.38	6.00	4.500	2.875	.38	1.20	3.00	.22	#10	2.40	7000		
FNYBUTWN020ALS	FNYBUTWN020ALLS	1.500	2.50	4.00	3.00	7.50	5.500	3.500	.44	1.50	3.75	.22	#10	5.00	10200		
FNYBUTWN024ALS	FNYBUTWN024ALLS	1.750	2.94	4.75	3.50	9.00	6.500	4.125	.50	1.75	4.50	.28	1/4	7.80	14000		

1 Compensated I.D. bearings have additional running clearance, ideally suited for high speed and non-parallel shaft applications.

2 Open bearings operating in shear should be derated by 40%. Open bearings operating in tension should be derated by 70%.

Note: For pillow block seals or non-self-aligning bearings, see Part Number Matrix on page 113.

**Flanged Pillow Blocks with Self-Aligning Bearings**

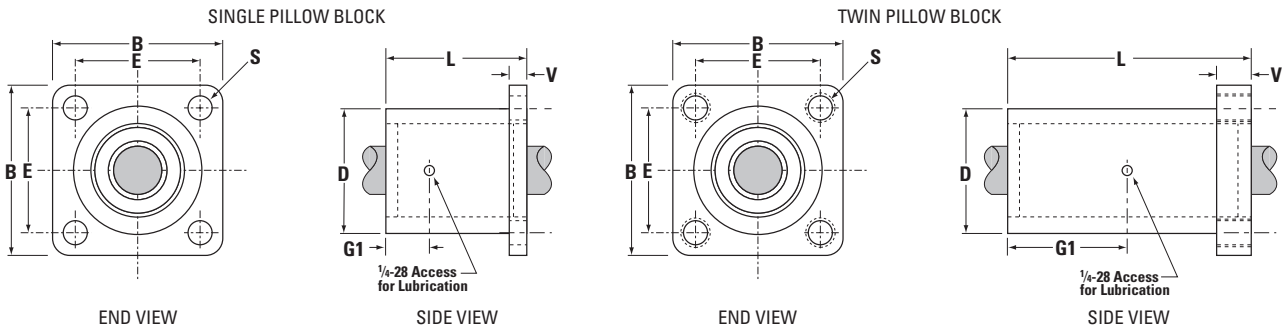

**Flanged Single Pillow Blocks with Self-Aligning Bearings**

Precision I.D.		Compensated I.D. <sup>1</sup>		Single Pillow Block Dimensions (in.)							
Part Number	Part Number	Nominal Bearing Diameter	B	E ±.010	L	D	V	G1 ±.010	S Shaft Hole Diameter	60 Case LinearRace Shaft Diameter	
										Min.	Max.
FNYBUF08ALS	FNYBUF08ALLS	.500	1.63	1.250	1.69	1.25	.25	.72	.19	.4990	.4995
FNYBUF12ALS	FNYBUF12ALLS	.750	2.38	1.750	2.06	1.75	.38	.89	.22	.7490	.7495
FNYBUF16ALS	FNYBUF16ALLS	1.00	2.75	2.125	2.81	2.25	.50	1.27	.28	.9990	.9995
FNYBUF20ALS	FNYBUF20ALLS	1.25	3.50	2.750	3.63	3.00	.63	1.67	.35	1.2490	1.2495
FNYBUF24ALS	FNYBUF24ALLS	1.50	4.00	3.125	4.00	3.62	.75	1.86	.41	1.4989	1.4994

**Flanged Twin Pillow Blocks with Self-Aligning Bearings**

Precision I.D.		Compensated I.D. <sup>1</sup>		Twin Pillow Block Dimensions (in.)							
Part Number	Part Number	Nominal Bearing Diameter	B	E ±.010	L	D	V	G1 ±.010	S Thread	60 Case LinearRace Shaft Diameter	
										Min.	Max.
FNYBTFB08ALS	FNYBTFB08ALLS	.500	1.63	1.250	3.20	1.25	.90	1.48	1/4 - 20	.4990	.4995
FNYBTFB12ALS	FNYBTFB12ALLS	.750	2.38	1.750	3.95	1.75	.90	1.98	1/4 - 20	.7490	.7495
FNYBTFB16ALS	FNYBTFB16ALLS	1.00	2.75	2.125	5.33	2.25	.90	2.67	1/4 - 18	.9990	.9995
FNYBTFB20ALS	FNYBTFB20ALLS	1.25	3.50	2.750	6.70	3.00	.90	3.35	5/16 - 18	1.2490	1.2495
FNYBTFB24ALS	FNYBTFB24ALLS	1.50	4.00	3.125	7.50	3.62	1.00	3.75	5/16 - 16	1.4989	1.4994

<sup>1</sup> Compensated I.D. bearings have additional running clearance, ideally suited for high speed and non-parallel shaft applications.  
 Note: For pillow block seals or non-self-aligning bearings, see Part Number Matrix below.

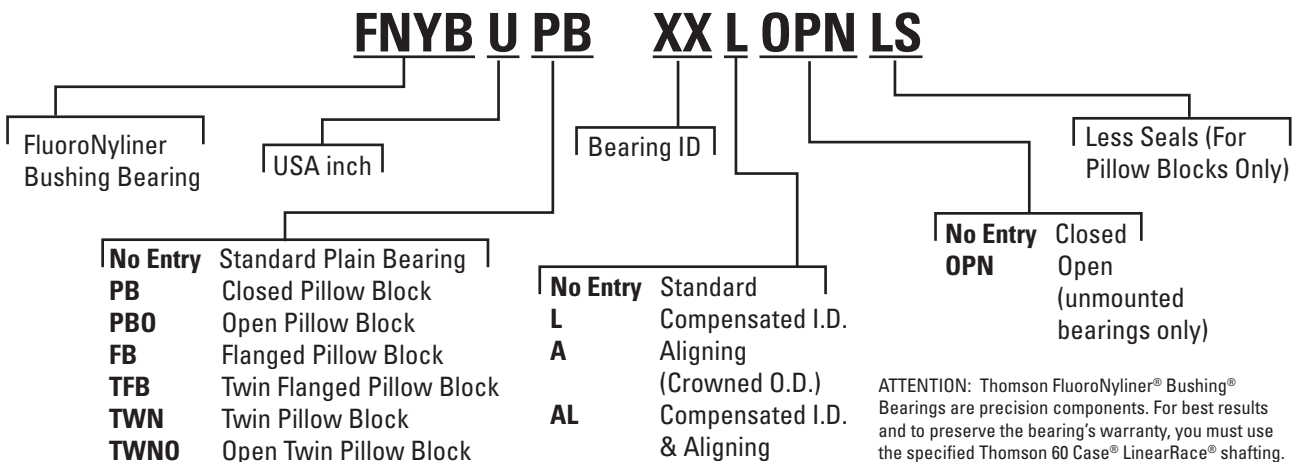

ATTENTION: Thomson FluoroNyliner® Bushing® Bearings are precision components. For best results and to preserve the bearing's warranty, you must use the specified Thomson 60 Case® LinearRace® shafting.

Not all options are available in all sizes.  
 See catalog pages or contact Thomson Customer Support for combination availability.  
 For additional information on bearing options, see page 267.



## Frictional Characteristics

I) Static: Tests performed on dry FNYBU16 bearings indicate that the force required to initiate motion is dependent upon the applied load according to the following equation:

$$F_f = 1.3 + 0.18 F_a$$

Where:

$F_f$  = Friction force, static (lb<sub>f</sub>)

$F_a$  = Applied force (lb<sub>f</sub>)

II) Dynamic: The coefficient of friction is dependent upon both the pressure and the velocity.

Pressure: Coefficient of friction decreases rapidly with increase in pressure.

Velocity: Coefficient of friction increases with an increase in velocity and quickly stabilizes.

For example, at 100 psi, the coefficient of friction is approximately 0.25 for velocities of 100 ft./min and higher.

Characteristic	Limit
Linear Temperature Range	-400° F to 550° F (-240° C to 288° C)
Velocity, dry	140 ft/min. Continuous
Velocity, dry	400 ft/min. Intermittent
Velocity, Lubricated	400 ft/min. Continuous
Pressure	1500 psi
PV	10,000 psi ft/min

**COEFFICIENT OF FRICTION VS. LOAD**  
(AT LOW SPEEDS)

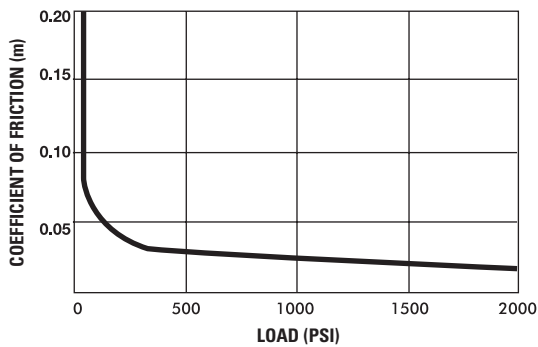

**COEFFICIENT OF FRICTION VS. SPEED**  
(AT 100 P.S.I.)

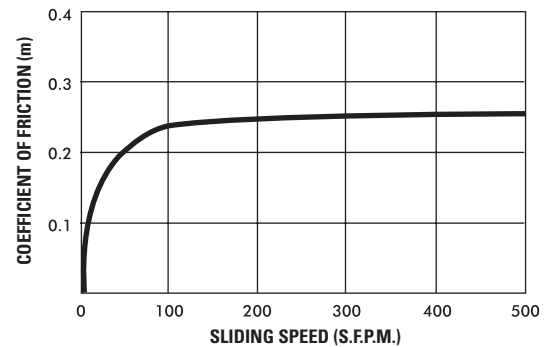

## Wear Rates and Life Expectancy

I) Wear rates: The wear rates of a plain bearing are dependent upon a number of variables, including characteristics of the counter-face, velocity, lubrication, load and contamination. Tests conducted on FNYBU16 bearings operating in the linear mode at approximately 70 ft./min, and at a pressure of approximately 33 psi, demonstrated an average radial wear change of 0.0011 inches, after 80 million inches of travel. This yields the following formula:

$$W_R = 14 \times (10^{-6}) \times T$$

Where:

$W_R$  = Radial Wear (micro-inches)

$T$  = Travel (inches)

II) Life expectancy: The life expectancy may be calculated from the wear rate. This is normally associated with the allowable radial clearance for a given application. The absolute wear limit is the bearing material thickness, which is 0.028 inches.

# FluoroNyliner<sup>®</sup> Bushing Bearing Chemical Resistance Chart

Chemical	Rating **		
	Bearing Liner	Aluminum Bearing Shell	Standard Hard Ceramic Coating (on Aluminum Bearing Shell)
2-butanone	A		
Acetic Acid, 20%	A	B	A
Acetone	A	B	A
Acetylene	A		A
Alkalines	D		
Ammonia	D		A
Ammonia, Anhydrous		B	A
Ammonium Chloride, 10%		C	C
Ammonium Hydroxide, 10%		C	C
Amyl Chloride	A		
Aniline	A		A
Barium Hydroxide		C	C
Beer	A	B	A
Benzaldehyde	A		A
Benzenesulfonic Acid	A	A	
Boric Acid Solutions	A	B	A
Bromine	A		A
Butane		B	A
Calcium Chloride, 20%	A	B	C
Calcium Hydroxide, 10%	D	B	B
Calcium Hypochlorite	A	B	B
Carbon Bisulfide	A		A
Carbon Dioxide	A		A
Carbon Monoxide	A	B	A
Carbon Tetrachloride	A	B	B
Chloral Hydrate or Chloroacetic Acid	A		
Chlorine gas, dry	A	B	A
Chlorine gas, wet	A	C	C
Chloroform or Chlorosulfonic Acid	A		
Chromic Acid, 10%	A	B	B
Citric Acid, 5%	A	B	A
Concentrated Oxidizing Acids	A		
Creosote	A		A
Decalin or Dichlorobenzene	A		
Diethyl Ether or Dimethylamine	A		
Dimethyl Sulfoxide	A		
Ethyl Acetate	A		A (122°F/50°C)
Ethyl Alcohol	A	B	A
Ethylene Glycol	A	B	A
Ferric Chloride, 50%	A	C	C
Ferric Nitrate	A		
Ferric Sulfate	A		
Ferrous Sulfate	A		
Fluoboric Acid	D		
Fluorinating Agents, strong	D		
Fluorine > 140°F & dry gas > 250°F	D		
Fluosilicic Acid	D		
Gasoline	A	B	A
Hydrobromic Acid	A		

Chemical	Rating **		
	Bearing Liner	Aluminum Bearing Shell	Standard Hard Ceramic Coating (on Aluminum Bearing Shell)
Hydrochloric Acid, 20% or 35%	A	C	B
Hydrocyanic Acid	A	C	C
Hydrocyanic Acid, 10%		B	C
Hydrofluoric Acid	D	C	C
Hydrofluosilicic Acid	D		
Hydrogen Fluoride, dry > 250°F	D		
Hydrogen Peroxide - dilute	A	B	A
Hydrogen Sulfide, dry	A	B	A
Hydrogen Sulfide, moist	A		A
Hydroxides	D		
Kerosene		B	A
Lactic Acid, 10%	A	B	A
Magnesium Chloride, 50%	A	C	B
Mercury	A	C	C
Methyl Alcohol		B	A
Methylene Chloride	A	B	B
Methylethyl Ketone	A	B	A (122°F/50°C)
Mineral Oil	A	B	A
Molten Alkali Metals	D		
Molten Anhydrous Base	D		
Naphtha	A	B	A
Nitric Acid, 70%	D	C	A
Nitro Benzene	A		A
Oleum	A		
Phosphoric Acid, 10%	A	C	C
Potassium Chlorate	D		
Potassium or Sodium Cyanide	A		
Potassium Dichromate	A		A
Potassium Hydroxide	D		C
Sea Water	A	B	A
Sodium Chlorate	A		
Sodium Chloride	A		A
Sodium Hydroxide, 20%	B	C	C
Sodium Hypochlorite, 20%	A	B	C
Sodium Peroxide, 10%		B	A
Stannous Chloride	A		
Sulfur Dioxide, dry	A	B	C
Sulfur Dioxide, 5% +H <sub>2</sub> O	A	C	C
Sulfuric Acid, 50%	A	C	C
Trichlorethylene	A		A
Toluene (122°F/50°C)	A	B	A
Trifluoroacetic Acid	A		
Turpentine	A	B	A
Water, demineralized	A	B	A
Water, distilled	A	C	A
Water, sewage		C	A
Xylene	A	B	A
Zinc Chloride solutions	A	C	B

## \*\* Rating Key

A = Little to no effect    B = Minor to moderate effect    C = Severe effect    D = Not Recommended  
Chemical effects are at room temperature unless otherwise noted.

All information contained herein is believed to be correct but is presented without any guaranty, warranty or representation of any kind, express or implied. Changes in temperature, concentration and/or combinations of chemicals may cause different results. Prior to use, it is recommended that the material be tested to determine its compatibility with a specific application. Contact Thomson applications engineers for more detailed information at 1-540-633-3549.



## Food-Grade FluoroNyliner<sup>®</sup> Bushing Bearings



### Description

Thomson Food-Grade FluoroNyliner Bushing Bearings are the first stainless steel, corrosion-resistant, self-lubricating Bushing Bearing with FDA-compliant liner materials. They are designed for use in food processing, pharmaceutical and medical applications.

The corrosion-resistant sleeve is stainless steel, while the self-lubricating liner is FDA and USDA compliant.

As the bearing does not utilize ball bearings, it can be run on soft shafting such as Thomson “corrosion proof” 316 Stainless Steel, making the Food-Grade FluoroNyliner excel in washdown applications.

### Features and Benefits

- 303 Stainless Steel, corrosion-resistant shell will not rust or otherwise contaminate applications.
- Self-lubricating liner eliminates costly maintenance and labor.
- Non-magnetic and corrosion resistant.
- FDA, USDA and washdown compliant.
- Special machining options available.
- Available in open and closed types.

Maximum PV, continuous	10,000 psi ft/min
Maximum P, static	1,000 psi
Maximum V, no load	400 ft/min
Temperature Range	-400°F to 385°F / -240°C to 196°C
Shaft Finish, recommended	8-16 Ra microinch
Coefficient of Friction	.12 - .20

## FluoroNyliner LinearRace Options

Food-Grade FluoroNyliner Bushing Bearings can be combined with a wide range of corrosion-resistant LinearRace options, depending on the application requirements:

- **440C Stainless Steel** Corrosion-resistant shafting with 50 HRC min case hardness
- **316 Stainless Steel** "Corrosion proof" shafting with no carbon content
- **Plated 60 Case® Options** Include Hard Chrome, Thin Dense Chrome and Black Oxide

## Pillow Block Options

Stainless steel pillow block assemblies are also available per request in closed, open and flanged styles, all of which are available as single or twin styles. Minimum orders may apply.

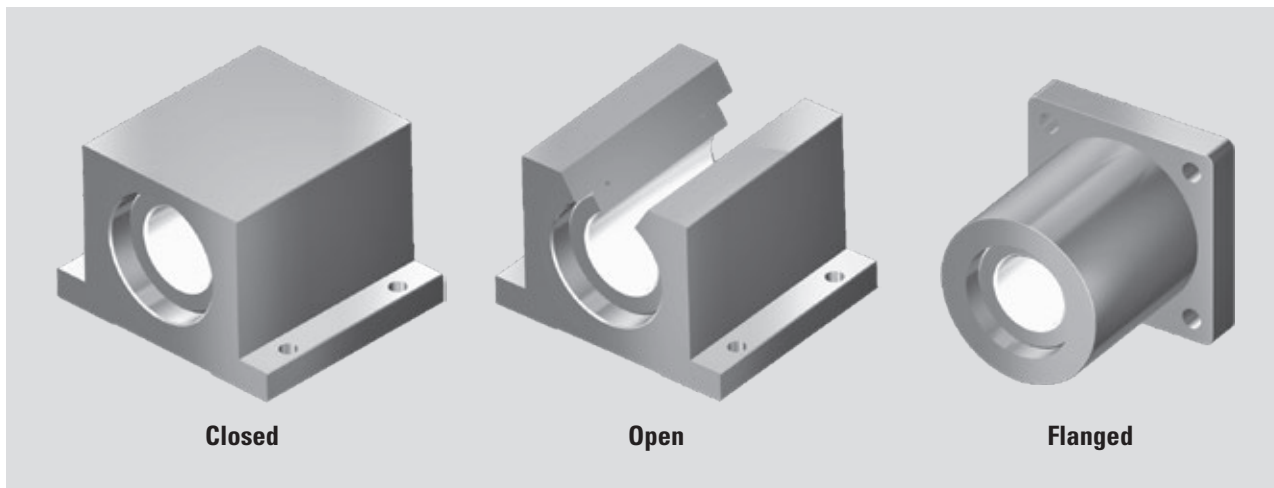

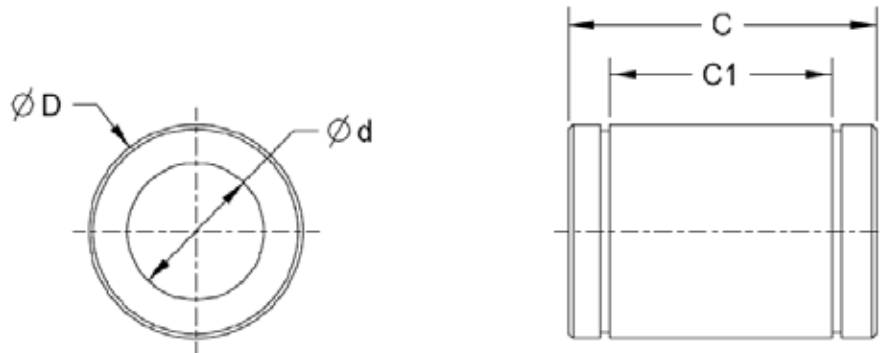

**Closed Type** (Dimensions in inches)

Part Number	Nominal Bearing Diameter	Working Bore Diameter (d)	Outside Diameter (D)	Length (C)	Distance Between Retaining Rings (C1)	Bearing Weight (lbs)
FNYBU06F	3/8	.3765/.3755	.6250/.6240	.875/.860	.562	.016
FNYBU08F	1/2	.5015/.5005	.8750/.8740	1.250/1.235	.875	.041
FNYBU10F	5/8	.6265/.6255	1.1250/1.1240	1.500/1.485	1.000	.091
FNYBU12F	3/4	.7518/.7508	1.2500/1.2490	1.625/1.610	1.062	.109
FNYBU16F	1	1.0018/1.0008	1.5625/1.5615	2.250/2.235	1.625	.228
FNYBU20F	1 1/4	1.2518/1.2508	2.0000/1.9990	2.625/2.605	1.875	.459
FNYBU24F	1 1/2	1.5018/1.5008	2.3750/2.3735	3.000/2.980	2.250	.750

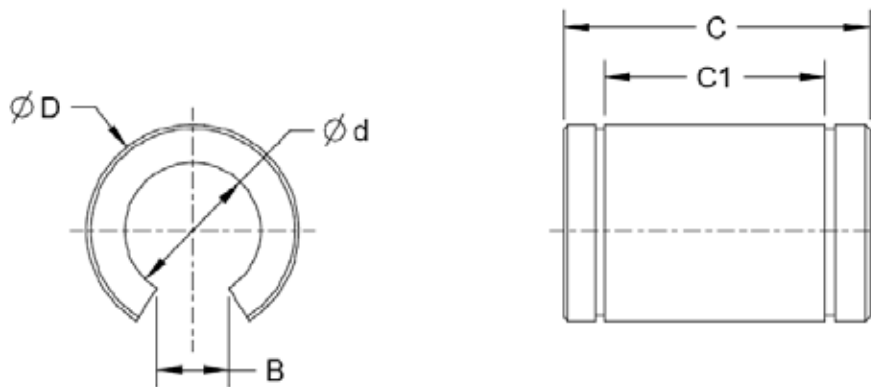

**Open Type** (Dimensions in inches)

Part Number	Nominal Bearing Diameter	Working Bore Diameter (d)	Outside Diameter (D)	Length (C)	Distance Between Retaining Rings (C1)	Slot Width Min (B)	Bearing Weight (lbs)
FNYBU06FOPN	3/8	.3765/.3755	.6250/.6240	.875/.860	.562	.156	.013
FNYBU08FOPN	1/2	.5015/.5005	.8750/.8740	1.250/1.235	.875	.312	.034
FNYBU10FOPN	5/8	.6265/.6255	1.1250/1.1240	1.500/1.485	1.000	.375	.072
FNYBU12FOPN	3/4	.7518/.7508	1.2500/1.2490	1.625/1.610	1.062	.438	.091
FNYBU16FOPN	1	1.0018/1.0008	1.5625/1.5615	2.250/2.235	1.625	.563	.184
FNYBU20FOPN	1 1/4	1.2518/1.2508	2.0000/1.9990	2.625/2.605	1.875	.625	.381
FNYBU24FOPN	1 1/2	1.5018/1.5008	2.3750/2.3735	3.000/2.980	2.250	.750	.630

## Polymer Bushing Bearings



### Description

Thomson polymer bushing bearings offer linear motion designers a reliable, yet economical, option for machines in which moment load is non-critical or where contamination is a concern. These bearings are also useful for applications that require shafting that is incompatible with Thomson Ball Bushing® Bearings such as aluminum or 316 stainless steel.

Handling loads up to 9000 N (2023 lbf), polymer bushing bearings provide a corrosion-resistant option for low-load, low-speed applications. When combined with round rail shafting, pillow blocks or other assembly components, polymer bushing bearings deliver a budget-friendly linear motion solution to a number of applications.

### Polymer Bushing Bearings Applications

- Factory Automation
- Robotics
- Health and Fitness
- Medical Automation
- Woodworking
- Packaging
- Food and Beverage
- Vending

### Polymer Bushing Bearings Highlights

- Available in sizes of 6 to 50 mm (closed) and 10 to 50 mm (open)
- Maintenance-free operation
- Polymer liners reduce noise
- Dirt and dust resistant
- Anodized aluminum adapter
- Available with aluminum pillow blocks
- Operate in temperatures ranging from -50°C to 90°C (-58°F to 194°F)
- Available in open and closed types



## Polymer Bushing Bearings - Closed Type

Dimensions	Projection
mm	

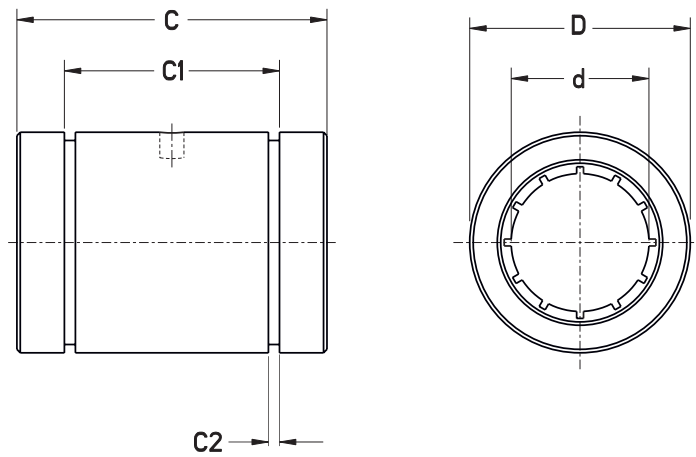

### Dimensions [mm]

Part Number	Inside Diameter (d)	Inside Diameter Tolerance	Outside Diameter (D)	Length (C)	Retaining Rings Distance (C1)	Retaining Rings Groove Width (C2)
PLM06	6	+0.020/+0.068	12	22	14.2	1.1
PLM08	8	+0.025/+0.083	16	25	16.2	1.1
PLM10	10	+0.030/+0.088	19	29	21.6	1.3
PLM12	12	+0.030/+0.088	22	32	22.6	1.3
PLM16	16	+0.030/+0.088	26	36	24.6	1.3
PLM20	20	+0.030/+0.091	32	45	31.2	1.6
PLM25	25	+0.030/+0.091	40	58	43.7	1.85
PLM30	30	+0.040/+0.110	47	68	51.7	1.85
PLM40	40	+0.040/+0.115	62	80	60.3	2.15
PLM50	50	+0.050/+0.0130	75	100	77.3	2.65

Part Number	Shaft Diameter	Dynamic Load F max. (N) P = 5 MPa	Static Load F max. (N) P = 35 MPa	Weight [kg]
PLM06	6	525	3675	5
PLM08	8	960	6720	9
PLM10	10	725	5075	12
PLM12	12	960	6720	20
PLM16	16	1440	10080	28
PLM20	20	2250	15750	50
PLM25	25	3625	25375	104
PLM30	30	5100	35700	163
PLM40	40	8000	56000	341
PLM50	50	9000	87500	589

**Polymer Bushing Bearings - Open Type**

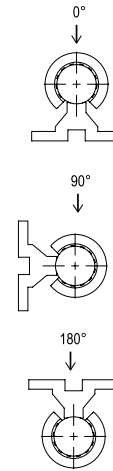
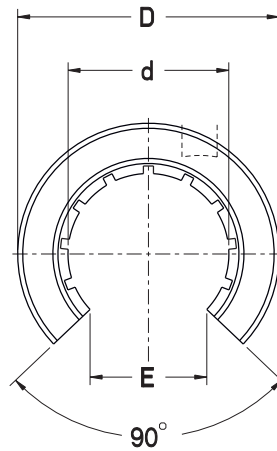
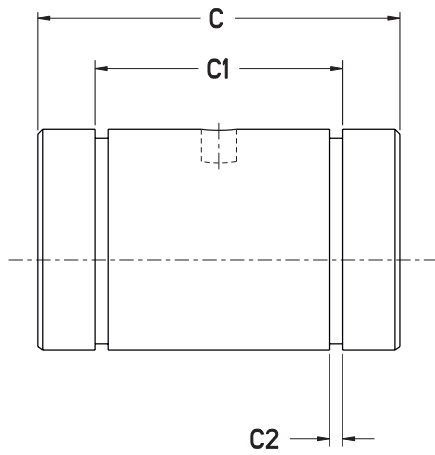

Dimensions	Projection
mm	

Dimensions [mm]

Part Number	Inside Diameter (d)	Inside Diameter Tolerance	Outside Diameter (D)	Length (C)	Retaining Rings Distance (C1)	Retaining Rings Groove Width (C2)	Opening Width (E)
PLM100PN	10	+0.030/+0.088	19	29	21.6	1.30	7.3
PLM120PN	12	+0.030/+0.088	22	32	22.6	1.30	9.0
PLM160PN	16	+0.030/+0.088	26	36	24.6	1.30	11.6
PLM200PN	20	+0.030/+0.091	32	45	31.2	1.60	12.0
PLM250PN	25	+0.030/+0.091	40	58	43.7	1.85	14.5
PLM300PN	30	+0.040/+0.110	47	68	51.7	1.85	16.6
PLM400PN	40	+0.040/+0.115	62	80	60.3	2.15	21.0
PLM500PN	50	+0.050/+0.130	75	100	77.3	2.65	25.5

Part Number	Shaft Diameter	Dynamic Load F max. (N) P = 5 MPa			Static Load F max. (N) P = 35 MPa			Weight [kg]
		0°	90°	180°	0°	90°	180°	
PLM100PN	10	725	500	196	5075	3500	1370	9
PLM120PN	12	960	635	240	6720	4445	1680	15
PLM160PN	16	1440	990	396	10080	6943	2772	21
PLM200PN	20	2250	1800	900	15750	12600	6300	37
PLM250PN	25	3625	2953	1523	25375	20670	10658	78
PLM300PN	30	5100	4250	2278	35700	29735	15948	122
PLM400PN	40	8000	6810	3800	56000	47660	26600	256
PLM500PN	50	12500	10750	6125	87500	75265	42875	442



## Polymer Bushing Bearings - Single and Twin Block Closed Type

Dimensions	Projection
mm	

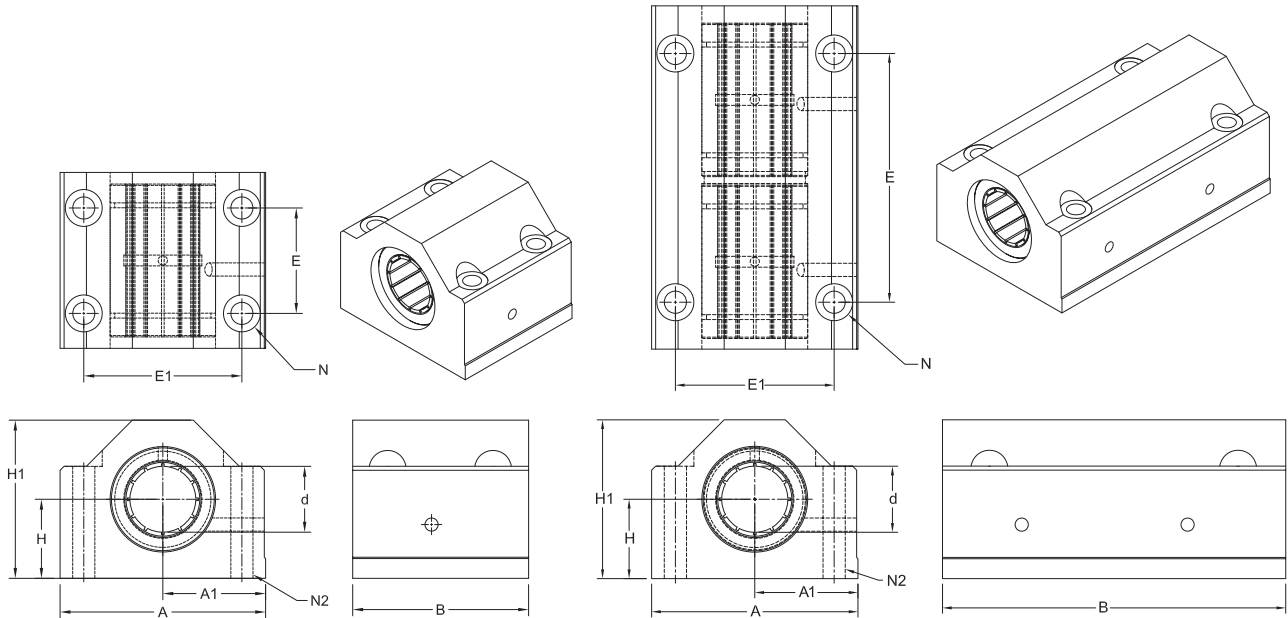

### Single Block Dimensions [mm]

Part Number	Inside Diam. (d)	Center Height $\pm 0.02$ (H)	Block Height (H1)	Block Width (A)	Center Width $\pm 0.02$ (A1)	Block Length (B)	Hole Length $\pm 0.1$ (E)	Hole Width $\pm 0.1$ (E1)	Hole Diam. (N)	Thread Size $\times$ Length (N2)	Weight [kg]
PLBM12	12	18	35	43	21.5	39	23	32	4.3	M5 $\times$ 11	0.117
PLBM16	16	22	42	53	26.5	43	26	40	5.3	M6 $\times$ 13	0.180
PLBM20	20	25	50	60	30.0	54	32	45	6.6	M8 $\times$ 18	0.300
PLBM25	25	30	60	78	39.0	67	40	60	8.4	M10 $\times$ 22	0.571
PLBM30	30	35	71	87	43.5	79	45	68	8.4	M10 $\times$ 22	0.889
PLBM40	40	45	91	108	54.0	91	58	86	10.5	M12 $\times$ 26	1.638

### Twin Block Dimensions [mm]

Part Number	Inside Diam. (d)	Center Height $\pm 0.02$ (H)	Block Height (H1)	Block Width (A)	Center Width $\pm 0.02$ (A1)	Block Length (B)	Hole Length $\pm 0.1$ (E)	Hole Width $\pm 0.1$ (E1)	Hole Diam. (N)	Thread Size $\times$ Length (N2)	Weight [kg]	Dynamic Load [N]	Static Load [N]
PLTBM12	12	18	35	43	21.5	75	56	32	4.3	M5 $\times$ 11	0.232	1920	13440
PLTBM16	16	22	42	53	26.5	84	64	40	5.3	M6 $\times$ 13	0.361	2880	20160
PLTBM20	20	25	50	60	30.0	104	76	45	6.6	M8 $\times$ 18	0.608	4500	31500
PLTBM25	25	30	60	78	39.0	130	94	60	8.4	M10 $\times$ 22	1.143	7250	50750
PLTBM30	30	35	71	87	43.5	152	106	68	8.4	M10 $\times$ 22	1.757	10200	71400
PLTBM40	40	45	91	108	54.0	176	124	86	10.5	M12 $\times$ 26	3.256	16000	112000

Polymer Bushing Bearings - Single and Twin Block Open Type

Dimensions	Projection
mm	

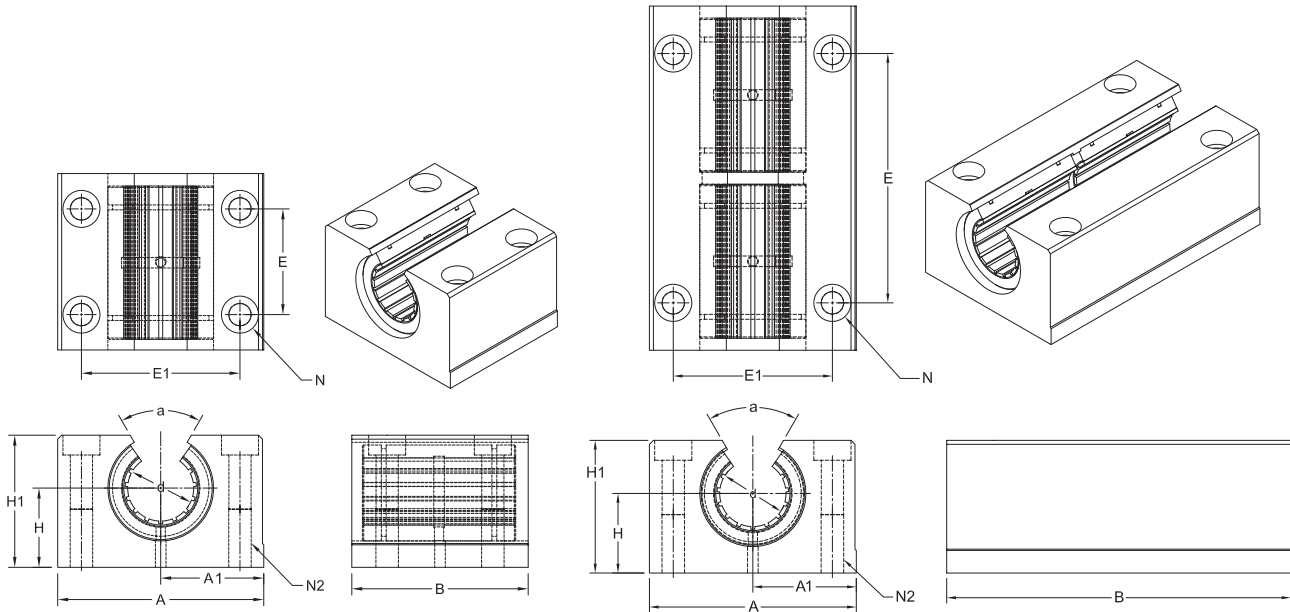

Single Block Dimensions [mm]

Part Number	Inside Diam. (d)	Center Height ± 0.02 (H)	Block Height (H1)	Block Width (A)	Center Width ± 0.02 (A1)	Block Length (B)	Hole Length ± 0.1 (E)	Hole Width ± 0.1 (E1)	Hole Diam. (N)	Thread Size × Length (N2)	Opening Angle (a) [°]	Weight [kg]
PLBM12PN	12	18	28	43	21.5	39	23	32	4.3	M5 × 11	66	0.097
PLBM16PN	16	22	35	53	26.5	43	26	40	5.3	M6 × 13	70	0.159
PLBM20PN	20	25	42	60	30.0	54	32	45	6.6	M8 × 18	50	0.253
PLBM25PN	25	30	51	78	39.0	67	40	60	8.4	M10 × 22	60	0.507
PLBM30PN	30	35	60	87	43.5	79	45	68	8.4	M10 × 22	55	0.797
PLBM40PN	40	45	77	108	54.0	91	58	86	10.5	M12 × 26	54	1.435

Twin Block Dimensions [mm]

Part Number	Inside Diam. (d)	Center Height ± 0.02 (H)	Block Height (H1)	Block Width (A)	Center Width ± 0.02 (A1)	Block Length (B)	Hole Length ± 0.1 (E)	Hole Width ± 0.1 (E1)	Hole Diam. (N)	Thread Size × Length (N2)	Opening Angle (a) [°]	Weight [kg]
PLTBM12PN	12	18	28	43	21.5	76	56	32	4.3	M5 × 11	66	0.197
PLTBM16PN	16	22	35	53	26.5	84	64	40	5.3	M6 × 13	70	0.323
PLTBM20PN	20	25	42	60	30.0	104	76	45	6.6	M8 × 18	50	0.508
PLTBM25PN	25	30	51	78	39.0	130	94	60	8.4	M10 × 22	60	1.028
PLTBM30PN	30	35	60	87	43.5	152	106	68	8.4	M10 × 22	55	1.588
PLTBM40PN	40	45	77	108	54.0	176	124	86	10.5	M12 × 26	54	2.879



## Polymer Bushing Bearings

### Speed vs. Load

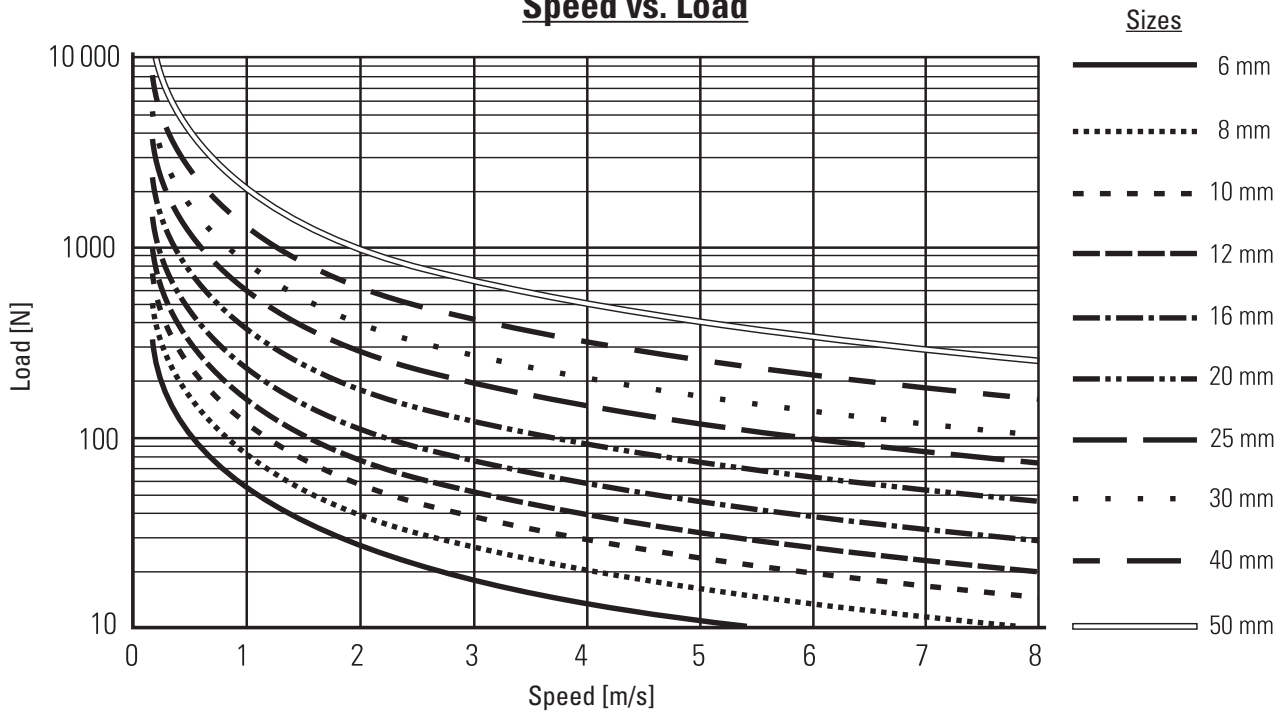

Technical Specifications		
Max. load	[N (lbf)]	9000 (2023)
Max. speed	[m/s (in/sec)]	8 (315)
Bushing sizes closed type	[mm]	6, 8, 10, 12, 16, 20, 25, 30, 40, 50
Bushing sizes open type	[mm]	10, 12, 16, 20, 25, 30, 40, 50
Operating temperature limits	[°C (°F)]	- 50 – 90 (- 58 – 194)
Housing material		anodized aluminum
Pillow block material		aluminum

Ordering Key		
1	2	3
PL	M08	OPN
1. Type PL = Polymer Bushing PLB = Polymer bushing pillow block PLTB = Polymer bushing twin pillow block	2. Size M08 = 8mm M10 = 10mm M12 = 12mm M16 = 16mm M20 = 20mm M25 = 25mm M30 = 30mm M40 = 40mm M50 = 50mm	3. Configuration (blank) = Closed OPN = Open

## Accessories



Described here are accessories for Linear Ball Bushing® Bearings and pillow blocks, including retaining rings, external seals, integral seals and resilient mounts.



## Lube for Life Mod Kits

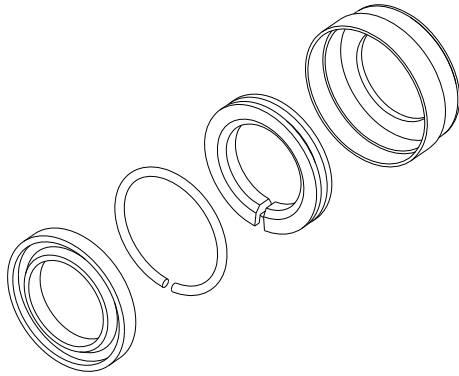

Lube for Life modification kits provide continuous bearing lubrication and enhanced protection for a broad range of applications. The Lube for Life attachments consist of a section of oil-saturated polymer actively compressed by a contact spring, inside a standard pillow block seal. Mod Kits are for use with non self-lubricating Super and Super Smart Ball Bushing® Bearing pillow blocks. Each Mod Kit includes two Lube for Life cartridges and assembly instructions.

### Closed Type Cartridges (Dimensions in inches)

Nominal Linear Race Diameter	Part Number	D1	D2	A	B
.500	MODKIT8-L4L	.94	.888	.45	.23
.750	MODKIT12-L4L	1.32	1.252	.46	.24
1.000	MODKIT16-L4L	1.63	1.565	.58	.30
1.250	MODKIT20-L4L	2.08	2.004	.78	.42
1.500	MODKIT24-L4L	2.46	2.379	.79	.43

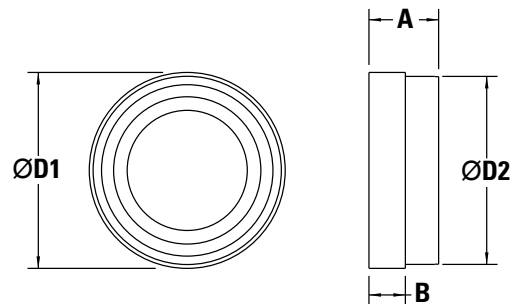

### Open Type Cartridges (Dimensions in inches)

Nominal Linear Race Diameter	Part Number	D1	D2	A	B
.500	MODKIT80PN-L4L	.94	.888	.43	.31
.750	MODKIT120PN-L4L	1.32	1.252	.43	.30
1.000	MODKIT160PN-L4L	1.63	1.565	.49	.30
1.250	MODKIT200PN-L4L	2.08	2.004	.78	.42
1.500	MODKIT240PN-L4L	2.46	2.379	.79	.43

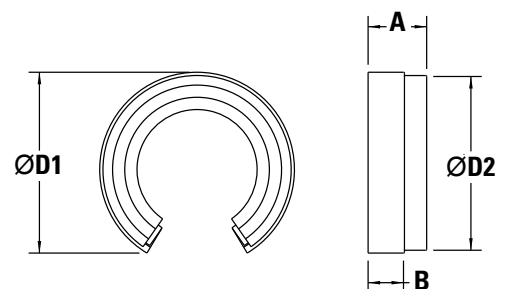

# Retaining Rings

## Internal Retaining Rings (Type PR)

Push-in retaining rings, as shown, are for use with Super Smart, Super and Precision Steel Ball Bushing closed type bearings. Each retaining ring is installed inside the housing bore at each end of the Ball Bushing bearing.

(Dimensions in inches)

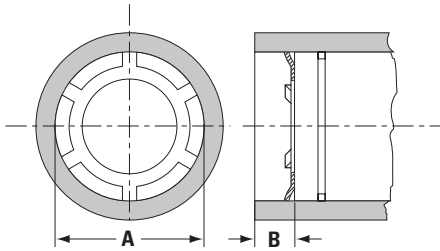

Part Number	Use with Ball Bushing bearing Part Number	Nominal Housing Bore A	Minimum End Space required B
PR250	SUPER4 or 4812 <sup>(1)</sup>	.500	.060
PR375	SUPER6 or 61014 <sup>(1)</sup>	.625	.060
PR500	SUPER8 or 81420 <sup>(1)</sup>	.875	.080
PR625	SSU10 or SUPER10 or 101824 <sup>(1)</sup>	1.125	.080
PR750	SSU12 or SUPER12 or 122026 <sup>(1)</sup>	1.250	.080
PR1000	SSU16 or SUPER16 or 162536 <sup>(1)</sup>	1.563	.080
PR1250	SSU20 or SUPER20 or 203242 <sup>(1)</sup>	2.000	.080
PR1500	SSU24 or SUPER24 or 243848 <sup>(1)</sup>	2.375	.100
PR2000	SUPER32 or 324864 <sup>(1)</sup>	3.000	.100

<sup>(1)</sup>Applies to A and XA Type Precision Steel Ball Bushing Bearings

## External Retaining Rings (Types C and W)

**Type W:** External retaining rings fit into the retaining ring grooves on the outside diameter of Super Smart, Super and Precision Steel Ball Bushing Bearings to provide external mounting retention. Available in standard and stainless steel versions.

**Type C:** External retaining rings fit into the retaining ring grooves on the outside diameter of Super Smart, Super and Precision Steel Ball Bushing Bearings (Open and Closed Type) to provide external mounting retention. Available in standard and stainless steel versions.

(Dimensions in inches)

### External Retaining Rings (Type W)

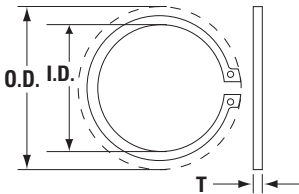

Standard Steel Part Number	Stainless Steel Part Number	Use with Ball Bushing Bearing Part Number	T	Installed Clearance O.D.	Free Diameter I.D.
-	W125SS	INST258SS <sup>(1)</sup>	.025	.52	.281
-	W187SS	INST369SS <sup>(1)</sup>	.025	.59	.338
W250	W250SS	SUPER4 or 4812 <sup>(1)</sup>	.035	.74	.461
W375	W375SS	SUPER6 or 61014 <sup>(1)</sup>	.035	.87	.579
W500	W500SS	SUPER8 or 81420 <sup>(1)</sup>	.042	1.16	.810
W625	W625SS	SSU10 or SUPER10 or 101824 <sup>(1)</sup>	.050	1.49	1.041
W750	W750SS	SSU12 or SUPER12 or 122026 <sup>(1)</sup>	.050	1.62	1.156
W1000	W1000SS	SSU16 or SUPER16 or 162536 <sup>(1)</sup>	.062	2.01	1.446
W1250	-	SSU20 or SUPER20 or 203242 <sup>(1)</sup>	.062	2.49	1.850
W1500	-	SSU24 or SUPER24 or 243848 <sup>(1)</sup>	.078	2.93	2.197
W2000	-	SUPER32 or 324864 <sup>(1)</sup>	.093	3.44	2.775
W2500	-	406080 <sup>(1)</sup>	.109	4.33	3.468
W3000	-	487296 <sup>(1)</sup>	.109	5.18	4.223
W4000	-	6496128 <sup>(1)</sup>	.125	6.66	5.631

<sup>(1)</sup>Applies to A, XA and OPN Type Precision Steel Ball Bushing Bearings

### External Retaining Rings (Type C)

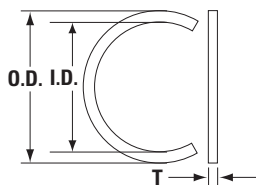

Standard Steel Part Number	Stainless Steel Part Number	Use with Ball Bushing Bearing Part Number	T	Installed O.D.	Installed I.D.
C250	C250SS	SUPER4 or 4812 <sup>(1)</sup>	.035	.55	.469
C375	C375SS	SUPER6 or 61014 <sup>(1)</sup>	.035	.673	.591
C500	C500SS	SUPER8 or 81420 <sup>(1)</sup>	.042	.923	.825
C625	C625SS	SSU10 or SUPER10 or 101824 <sup>(1)</sup>	.050	1.18	1.068
C750	C750SS	SSU12 or SUPER12 or 122026 <sup>(1)</sup>	.050	1.301	1.183
C1000	C1000SS	SSU16 or SUPER16 or 162536 <sup>(1)</sup>	.062	1.62	1.475
C1250	-	SSU20 or SUPER20 or 203242 <sup>(1)</sup>	.062	2.04	1.895
C1500	-	SSU24 or SUPER24 or 243848 <sup>(1)</sup>	.078	2.448	2.25

<sup>(1)</sup>Applies to A, XA and OPN Type Precision Steel Ball Bushing Bearings



## External Seals

### Seals for Fixed Diameter Housings

Double-acting seals for Super Smart, Super and Precision Steel closed type Ball Bushing® Bearings. Standard and stainless versions. Sizes 1 1/2 inch and above use spring fingers to reinforce sealing capability, which could add to seal drag. Standard and stainless steel versions.

(Dimensions in inches)

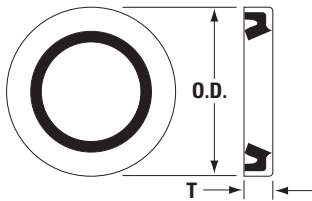

Standard Steel Seal Part Number	Stainless Steel Seal Part Number	Use with Ball Bushing Bearing Part Number	Nominal Linear Race Diameter	T	O.D.
S250	S250SS	SUPER4 or 4812 <sup>(1)</sup>	.250	.125	.504
S375	S375SS	SUPER6 or 61014 <sup>(1)</sup>	.375	.125	.629
S500	S500SS	SUPER8 or 81420 <sup>(1)</sup>	.500	.125	.879
S625	S625SS	SSU10 or SUPER10 or 101824 <sup>(1)</sup>	.625	.125	1.129
S750	S750SS	SSU12 or SUPER12 or 122026 <sup>(1)</sup>	.750	.125	1.254
S1000	S1000SS	SSU16 or SUPER16 or 162536 <sup>(1)</sup>	1.000	.187	1.567
S1250	-	SSU20 or SUPER20 or 203242 <sup>(1)</sup>	1.250	.375	2.004
S1500	-	SSU24 or SUPER24 or 243848 <sup>(1)</sup>	1.500	.375	2.379
S2000	-	SUPER32 or 324864 <sup>(1)</sup>	2.000	.375	3.004
S2500	-	406080 <sup>(1)</sup>	2.500	.375	3.756
S3000	-	487296 <sup>(1)</sup>	3.000	.500	4.506
S4000	-	6496128 <sup>(1)</sup>	4.000	.500	6.006

<sup>(1)</sup>Applies to A and XA Precision Steel Ball Bushing Bearings

### Seals for Adjustable Housing

Double-acting seals for Super Smart, Super and Precision Steel Ball Bushing Bearings. Seals have a radial slot through the circumferences to facilitate diameter adjustment. Standard and stainless steel versions.

(Dimensions in inches)

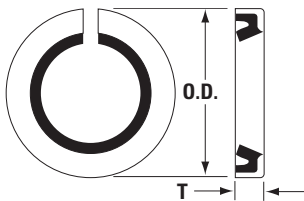

Standard Steel Seal Part Number	Stainless Steel Seal Part Number	Use with Ball Bushing Bearing Part Number	Nominal Linear Race Diameter	T	O.D.
ADJS500	ADJS500SS	SUPER8 or 81420 <sup>(2)</sup>	.500	.125	.879
ADJS625	ADJS625SS	SSU10 or SUPER10 or 101824 <sup>(2)</sup>	.625	.125	1.129
ADJS750	ADJS750SS	SSU12 or SUPER12 or 122026 <sup>(2)</sup>	.750	.125	1.254
ADJS1000	ADJS1000SS	SSU16 or SUPER16 or 162536 <sup>(2)</sup>	1.000	.187	1.567
ADJS1250	-	SSU20 or SUPER20 or 203242 <sup>(2)</sup>	1.250	.375	2.004
ADJS1500	-	SSU24 or SUPER24 or 243848 <sup>(2)</sup>	1.500	.375	2.379
ADJS2000	-	SUPER32 or 324864 <sup>(2)</sup>	2.000	.375	3.004
ADJS2500	-	406080 <sup>(2)</sup>	2.500	.375	3.756
ADJS3000	-	487296 <sup>(2)</sup>	3.000	.500	4.506
ADJS4000	-	6496128 <sup>(2)</sup>	4.000	.500	6.006

<sup>(2)</sup>Applies to ADJ type Precision Steel Ball Bushing Bearings

### Seals for Open Type Housing

Double-acting seals for Super Smart, Super and Precision Steel Ball Bushing Open Type bearings. Standard and stainless steel versions.

(Dimensions in inches)

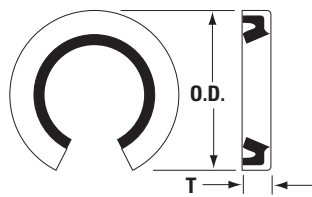

Standard Steel Seal Part Number	Stainless Steel Seal Part Number	Use with Open Type Ball Bushing Bearing Part Number	Nominal Linear Race Diameter	T	O.D.
OPNS500	OPNS500SS	SUPER80PN or 81420 <sup>(3)</sup>	.500	.125	.879
OPNS625	OPNS625SS	SSU100PN or SUPER100PN or 101824 <sup>(3)</sup>	.625	.125	1.129
OPNS750	OPNS750SS	SSU120PN or SUPER120PN or 122026 <sup>(3)</sup>	.750	.125	1.254
OPNS1000	OPNS1000SS	SSU160PN or SUPER160PN or 162536 <sup>(3)</sup>	1.000	.187	1.567
OPNS1250	-	SSU200PN or SUPER200PN or 203242 <sup>(3)</sup>	1.250	.375	2.004
OPNS1500	-	SSU240PN or SUPER240PN or 243848 <sup>(3)</sup>	1.500	.375	2.379
OPNS2000	-	SUPER320PN or 324864 <sup>(3)</sup>	2.000	.375	3.004
OPNS2500	-	406080 <sup>(3)</sup>	2.500	.375	3.756
OPNS3000	-	487296 <sup>(3)</sup>	3.000	.500	4.506
OPNS4000	-	6496128 <sup>(3)</sup>	4.000	.500	6.006

<sup>(3)</sup>Applies to OPN type Precision Steel Ball Bushing Bearings

## Integral Seals

### Seals for Sealed Super Ball Bushing Bearings (Closed Type)

Double-acting replacement seals for the Sealed Super Ball Bushing Bearing.

(Dimensions in inches)

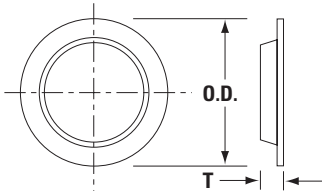

Part number	Use with Super Ball Bushing Bearing Number	Nominal LinearRace Diameter	T	O.D.
S500-DD	SUPER8-DD	.500	.120	.770
S625-DD	SUPER10-DD	.625	.120	1.010
S750-DD	SUPER12-DD	.750	.120	1.110
S1000-DD	SUPER16-DD	1.000	.180	1.390

### Seals for Sealed Super Ball Bushing Bearings (Open Type)

Double-acting replacement seals for the Sealed Super Ball Bushing Bearing.

(Dimensions in inches)

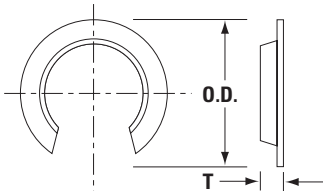

Part Number	Use with Super Ball Bushing Bearing Number	Nominal LinearRace Diameter	T	O.D.
S500PN-DD	SUPER80PN-DD	.500	.120	.770
S625PN-DD	SUPER100PN-DD	.625	.120	1.010
S750PN-DD	SUPER120PN-DD	.750	.120	1.110
S1000PN-DD	SUPER160PN-DD	1.000	.180	1.390

### Felt Seals for Closed Type Ball Bushing Bearings

Felt seals for Super Smart, Super and Precision Steel closed type Ball Bushing Bearings. Felt seals reduce drag for applications where reduced friction is critical. Felt seals provide minimal protection from the ingress of contamination. Use PR type external retaining rings for retention.

(Dimensions in inches)

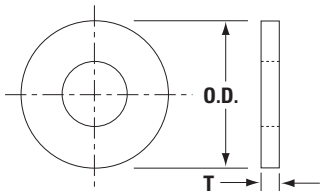

<sup>(1)</sup>Applies to A, XA and ADJ Type Precision Steel Ball Bushing Bearings

Standard Felt Seal Part Number	Use with Ball Bushing Bearing Part Number	Nominal LinearRace Diameter	T	O.D.
FS250	SUPER4 or 4812 <sup>(1)</sup>	.250	.125	.500
FS375	SUPER6 or 61014 <sup>(1)</sup>	.375	.125	.625
FS500	SUPER8 or 81420 <sup>(1)</sup>	.500	.125	.875
FS625	SSU10 or SUPER10 or 101824 <sup>(1)</sup>	.625	.125	1.125
FS750	SSU12 or SUPER12 or 122026 <sup>(1)</sup>	.750	.125	1.250
FS1000	SSU16 or SUPER16 or 162536 <sup>(1)</sup>	1.000	.125	1.563
FS1250	SSU20 or SUPER20 or 203242 <sup>(1)</sup>	1.250	.188	2.000
FS1500	SSU24 or SUPER24 or 243848 <sup>(1)</sup>	1.500	.188	2.375
FS2000	SUPER32 or 324864 <sup>(1)</sup>	2.000	.188	3.000

<sup>(1)</sup>Applies to A, XA and ADJ type Precision Steel Ball Bushing Bearings

### Seals for RoundWay Linear Roller Bearings

Standard seals for both single and dual types.

(Dimensions in inches)

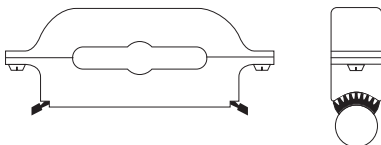

Seal Number	Nominal LinearRace Diameter	Overall Length L	Overall Width W	Overall Height from Centerline of LinearRace H
RS16	1.000	5.00	1.00	2.25
RS24	1.500	6.50	1.38	3.25
RS32	2.000	8.50	1.88	4.25
RS48	3.000	13.00	2.63	6.50
RS64	4.000	17.00	3.38	8.50



## RoundWay® Bearing Replacement Parts

RoundWay Bearing Part Number	RoundWay Roller Assembly All Bearing Types	RoundWay Eccentric Trunnion Pin Bearing Types A, S, V	RoundWay Eccentric Trunnion Pin Bearing Type B	RoundWay Eccentric Trunnion Pin Bearing Type C	RoundWay Bearing Race
RW8x	R124A8	R112A	R138A	R130A	R366C
RW16x	R124A16	R113A	R139A	R131A	R367C
RW24x	R124A24	R114A	R140A	R132A	R368C
RW32x	R124A32	R115A	R141A	R133A	R369C
RW48x	R124A48	R201A	R212A	R218A	R370C
RW64x	R124A64	R202A	R213A	R219A	R371C

## Resilient Mounts

### Resilient Ball Bushing® Bearing Mounts for Ease of Installation

Used with Precision Steel Ball Bushing Bearings Type A and XA. Resilient Ball Bushing Bearing mounts are sometimes used when absolute rigidity is not essential and where a slightly larger housing bore can be accommodated. The self-aligning feature of these mounts guarantee uniform load distribution over the entire length of the load carrying balls and compensates for slight errors in housing bores and parallel 60 Case® LinearRace® alignment. The mount consists of a band of resilient material that can be easily mounted to the outside diameter of the Ball Bushing Bearing. After it is installed in the housing bore, it provides permanent resilient, self-aligning support for the bearing. Resilient mounts consist of one rubber ring, two spacers and two retaining rings. Ball Bushing Bearings must be purchased separately.

(Dimensions in inches)

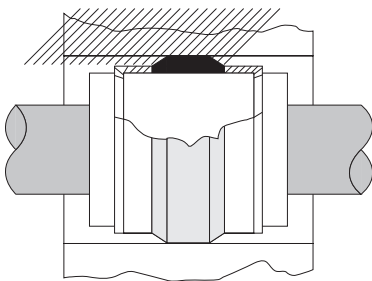

Resilient Mount Assembly Part Number	Use with Ball Bushing Bearing Number	Nominal LinearRace Diameter	Recommended Housing Bore ±.005
RSL250	A or XA4812	.250	.625
RSL375	A or XA61014	.375	.750
RSL500	A or XA81420	.500	1.000
RSL625	A or XA101824	.625	1.313
RSL750	A or XA122026	.750	1.438
RSL1000	A or XA162536	1.000	1.813
RSL1250	A or XA203242	1.250	2.313
RSL1500	A or XA243848	1.500	2.750

## Thomson Linear Motion Metric Components

**The RoundRail Advantage** - The inherent ability of a RoundRail Ball Bushing Bearing system to absorb torsional misalignment caused by inaccuracies in carriage or base machining or machine deflection...with little increase in stress to bearing components.

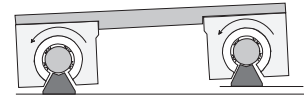

### Super Smart Ball Bushing Bearings

**Thomson Super Smart Ball Bushing Bearings represent a major advancement for linear bearing technology worldwide.**

This patented, self-aligning linear bearing provides two times the load carrying capacity of the industry standard Thomson Super Ball Bushing Bearing. Super Smart Ball Bushing Bearings also provide eight times the bearing life and up to five times the LinearRace shaft life when used in place of standard Super type bearings. See page 133.



### Super Smart Ball Bushing Pillow Blocks

**Thomson Super Smart Ball Bushing pillow blocks available in closed, adjustable and open styles in both single and twin versions.**

To minimize installation time and cost, the Super Smart Ball Bushing Bearing can be ordered factory installed in an industry standard single or twin pillow block. The closed-type pillow block is used in end-supported applications for spanning or bridging a gap. The open style is used in continuously supported applications when maximum rigidity and stiffness is required. Each Super Smart pillow block is complete with integral double-acting seals which keep out contaminants, retain lubrication and maximize bearing life. Since each pillow block is dimensionally interchangeable with industry standard pillow blocks, system performance improvements can be realized immediately. See page 142.



### MultiTrac Ball Bushing Bearings

**Rigid, high load capacity, linear bearings**

Extremely rigid MultiTrac Ball Bushing Bearings give you less deflection and twice the load capacity or eight times the travel life of conventional Ball Bushing Bearings. This increased bearing performance significantly reduces downtime and maintenance, while increasing machine reliability. The improvement in bearing capacity permits designers to optimize system compactness and minimizes hardware costs. The bearing's patented ball control technology eliminates binding and chatter (stick-slip) common to high-friction, plain bushings. See page 154.



## Super Ball Bushing® Bearings and Pillow Blocks High performance from superior design.

A coefficient of friction as low as 0.001. This allows the use of smaller, less expensive motors, belts, gears and ball screws when replacing high-friction, plain bearings. A self-aligning capability up to  $0.5^\circ$  compensates for inaccuracies in base flatness or carriage machining. Achieved with Thomson Super Bearing plates, which have defined radius crowns for maximized self-alignment accuracy. Accelerations as high as  $150 \text{ m/s}^2$  and steady state travel speeds up to  $3 \text{ m/s}$  without the derating factors commonly required with linear guides. Quick to ship, drop-in replacement parts for existing applications. Twin version with two Super Ball Bushing Bearings providing twice the load capacity or eight times more travel life than the single version.

See page 166.

## Application

Thomson products are engineered to world-class performance standards so that you can specify them with confidence worldwide. This Engineering Support section provides charts, formulas and technical information for:

- Ball Bushing Bearing selection
- Load considerations for horizontal-, side- and vertical-mounted applications
- Shaft deflection
- Installation
- Tolerance zones for internal and external diameters

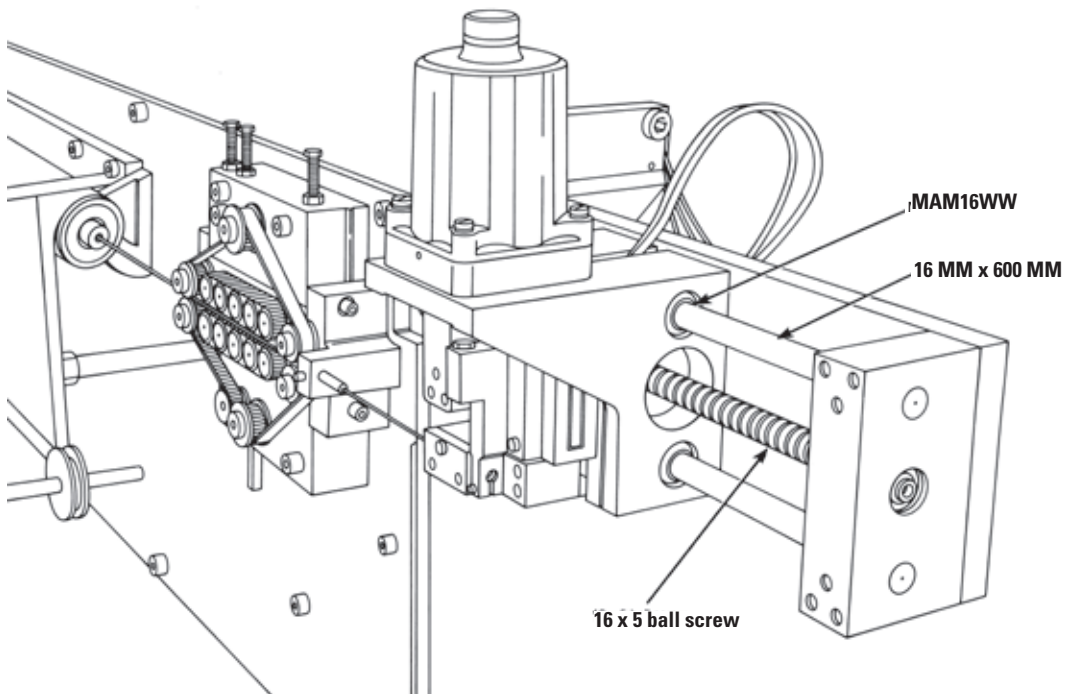

## Super Smart Ball Bushing Bearings



### Thomson Super Smart Ball Bushing Bearing products offer:

- Up to six times the load capacity or 216 times the travel life of conventional linear bearings.
- Twice the load capacity or eight times the travel life of industry standard Thomson Super Ball Bushing Bearings.
- Universal self-alignment feature that compensates for misalignment of housing bores and 60 Case<sup>®</sup> LinearRace<sup>®</sup> shaft deflection, optimizes load distribution between ball tracks and assures uniform ball loading over the entire length of the bearing plate. Installation time and cost is minimized, while bearing performance and life is maximized.
- Technologically advanced design that allows the bearing to maintain its diametral fit-up when installed in a housing that is slightly out-of-round.
- Up to 400% longer LinearRace shaft life and minimal machine downtime when replacing conventional linear bearings or the standard Super Ball Bushing Bearing.
- RoundRail Advantage combined with universal self-alignment, eliminating the need for derating factors commonly required when using linear guides.
- Coefficient of friction as low as 0.001. This allows the use of smaller, less expensive motors, belts, gears and ball screws, when replacing high friction, plain bearings.
- Closed and open configurations.
- Double-lip integral wipers that keep out dirt while retaining lubrication. Travel life is maximized.

**Available in both European and JIS standard dimensions.**



# Part Number Description and Specification

## Super Smart Ball Bushing® Bearings (Closed Type) for End-Supported Applications

### SSEM160PNWW-CR

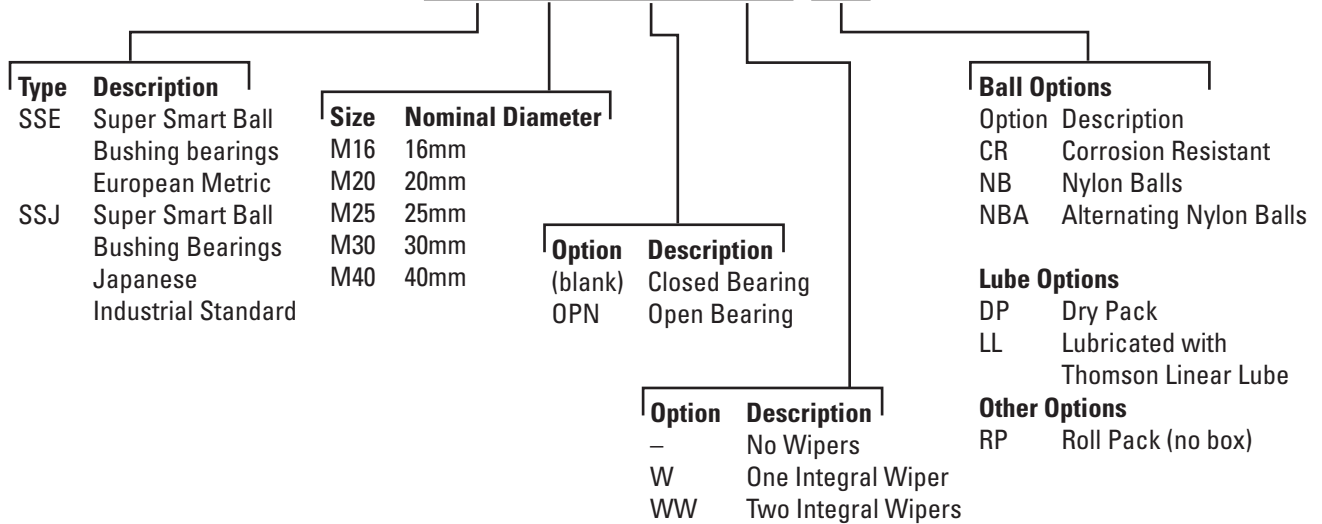

Not all options are available in all sizes.

See catalog pages or contact Thomson Customer Support for combination availability.

For additional information on bearing options, see page 267.

# The Super Smart Advantage

## Advantage: Load Capacity

The Super Smart Ball Bushing Bearing provides twice the load capacity of the industry standard Thomson Super Ball Bushing Bearing and six times the load capacity of conventional linear bearings.

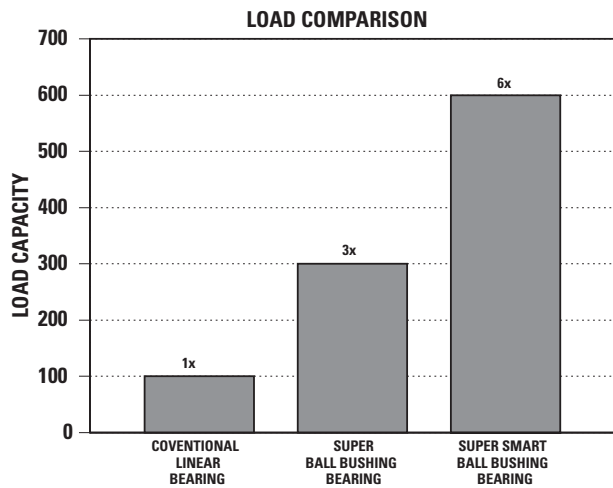

### Downsizing

The photograph above shows a conventional Ball Bushing Bearing, Super Ball Bushing Bearing and Super Smart Ball Bushing Bearing, all of which have the same load capacity.

## Advantage: Travel Life

The Super Smart Ball Bushing Bearing provides eight times the travel life of the industry standard Thomson Super Ball Bushing Bearing and 216 times the travel life of conventional linear bearings.

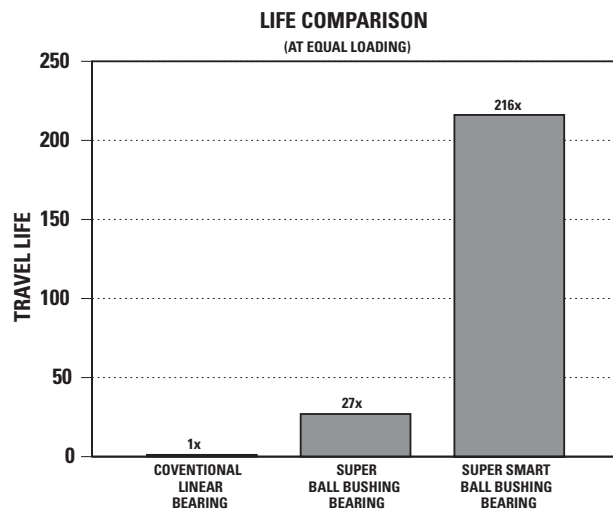



# Super Smart Ball Bushing® Bearings (Closed Type)

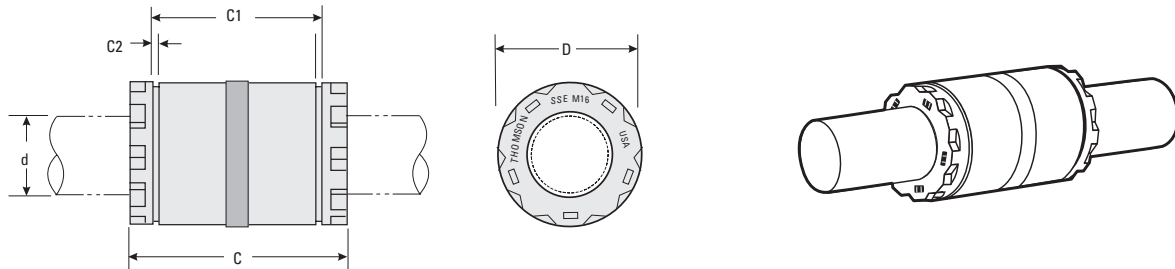

## Super Smart Ball Bushing Bearings (Closed Type) (Dimensions in mm)

Part Number			d <sup>(4)</sup>	D	C h14	C1 H13	C2 min.	Number of Ball Tracks	Mass (kg)	Dynamic Load W <sup>(1)(3)</sup> (N)	Load Limit W <sub>0</sub> <sup>(2)(3)</sup> (N)
Without Integral Wipers	With one Integral Wiper	With two Integral Wipers									
SSEM16	SSEM16W	SSEM16WW	16	26	36	24.6	1.30	10	0.030	2200	2400
SSEM20	SSEM20W	SSEM20WW	20	32	45	31.2	1.60	10	0.066	4000	4400
SSEM25	SSEM25W	SSEM25WW	25	40	58	43.7	1.85	10	0.135	6700	7300
SSEM30	SSEM30W	SSEM30WW	30	47	68	51.7	1.85	10	0.206	8300	9100
SSEM40	SSEM40W	SSEM40WW	40	62	80	60.3	2.15	10	0.392	13700	15000

(1) For rated travel life of 100 km. For longer travel lives, reduce load to  $\bullet(100/L)^{0.33}$  where L (km) is the required travel life. Do not exceed the Dynamic Load Rating for travel life of less than 100 km.

(2) The Load Limit is the maximum load that may be applied to a bearing/shaft. It is important to analyze the application so that peak and/or shock do not exceed the Load Limit.

(3) The load capacities W and W<sub>0</sub> are valid for a resultant load applied at 90° with the ball tracks oriented as shown in the polar graphs below. If the resultant acts along another direction, the appropriate multiplicative correction factor K<sub>e</sub> should be applied to W and W<sub>0</sub> respectively. Open type bearings have reduced load capacities when used in pull-off situations.

(4) Internal bearing diameter is affected by the housing bore, see Table 1.

(5) Hole for anti-rotation pin is below centerline.

NOTE: For part number description and specifications, see page 134.

NOTE: External seals and retaining rings are available. See page 173 for specifications.

NOTE: For additional technical information, see the Engineering section beginning on page 256.

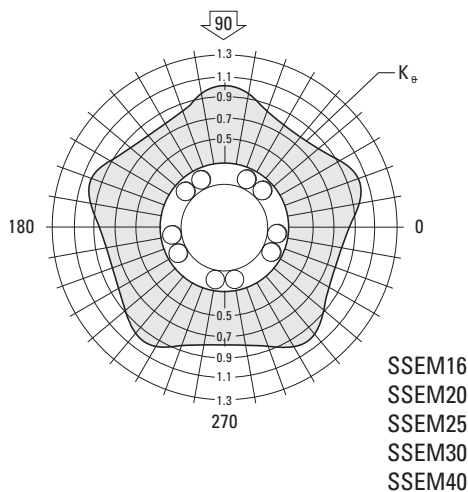

# Super Smart Ball Bushing Bearings (Open Type)

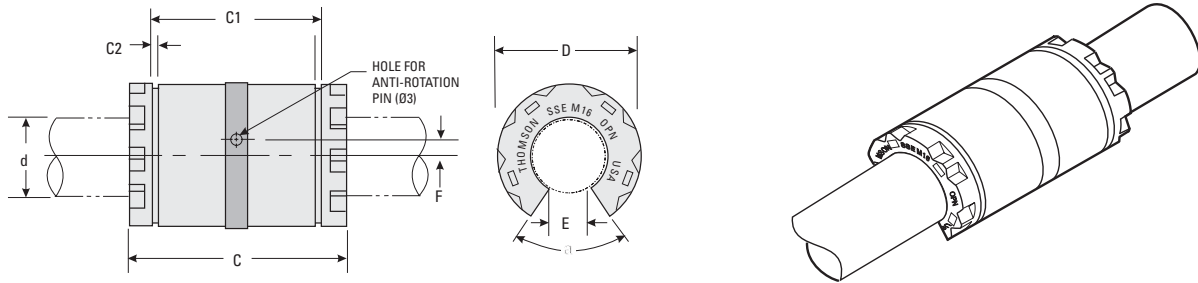

**Super Smart Ball Bushing Bearings (Open Type)** (Dimensions in mm)

Part Number			d <sup>(4)</sup>	D	C h14	C1 H13	C2 min.	E	F	Angle $\alpha$ (deg)	Number of Ball Tracks	Mass (kg)	Dynamic Load W <sup>(1)(3)</sup> (N)	Load Limit W <sub>0</sub> <sup>(2)(3)</sup> (N)
Without Integral Wipers	With one Integral Wiper	With two Integral Wipers												
SSEM160PN	SSEM160PNW	SSEM160PNWW	16	26	36	24.6	1.30	9.0	0	70	8	0.023	2200	2400
SSEM200PN	SSEM200PNW	SSEM200PNWW	20	32	45	31.2	1.60	10.0	0	50	8	0.054	4000	4400
SSEM250PN	SSEM250PNW	SSEM250PNWW	25	40	58	43.7	1.85	12.5	1.50 <sup>(5)</sup>	60	8	0.107	6700	7300
SSEM300PN	SSEM300PNW	SSEM300PNWW	30	47	68	51.7	1.85	13.7	2.00	55	8	0.163	8300	9100
SSEM400PN	SSEM400PNW	SSEM400PNWW	40	62	80	60.3	2.15	19.0	1.50	54	8	0.315	13700	15000

(1) For rated travel life of 100 km. For longer travel lives, reduce load to  $\bullet(100/L)^{0.33}$  where L (km) is the required travel life. Do not exceed the Dynamic Load Rating for travel life of less than 100 km.

(2) The Load Limit is the maximum load that may be applied to a bearing/shaft. It is important to analyze the application so that peak and/or shock do not exceed the Load Limit.

(3) The load capacities W and W<sub>0</sub> are valid for a resultant load applied at 90° with the ball tracks oriented as shown in the polar graphs below. If the resultant acts along another direction, the appropriate multiplicative correction factor K<sub>e</sub> should be applied to W and W<sub>0</sub> respectively. Open type bearings have reduced load capacities when used in pull-off situations.

(4) Internal bearing diameter is affected by the housing bore, see Table 1.

(5) Hole for anti-rotation pin is below centerline.

NOTE: For part number description and specifications, see page 134.

NOTE: External seals and retaining are available. See page 173 for specifications.

NOTE: For additional technical information, see the Engineering section beginning on page 256.

**Table 1 - Standard Diametral Clearances**

Nominal Shaft Diameter d (mm)	Nominal Housing Bore Diameter d (mm)	Diametral Clearance	
		Housing Bore H7 (µm)	Housing Bore H6 (µm)
16	26	+33 +4	+26 +3
20	32	+37 +6	+30 +4
25	40	+37 +6	+30 +4
30	47	+37 +6	+30 +4
40	62	+44 +7	+35 +5

For Super Smart Ball Bushing Bearings mounted in a housing and with LinearRace shafts, h6 tolerance

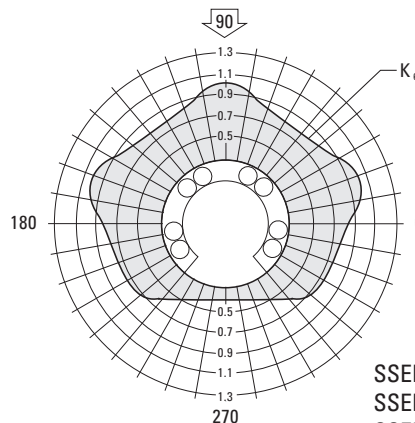

SSEM160PN  
SSEM200PN  
SSEM250PN  
SSEM300PN  
SSEM400PN



# Super Smart Ball Bushing® Bearings - JIS Specifications (Closed Type)

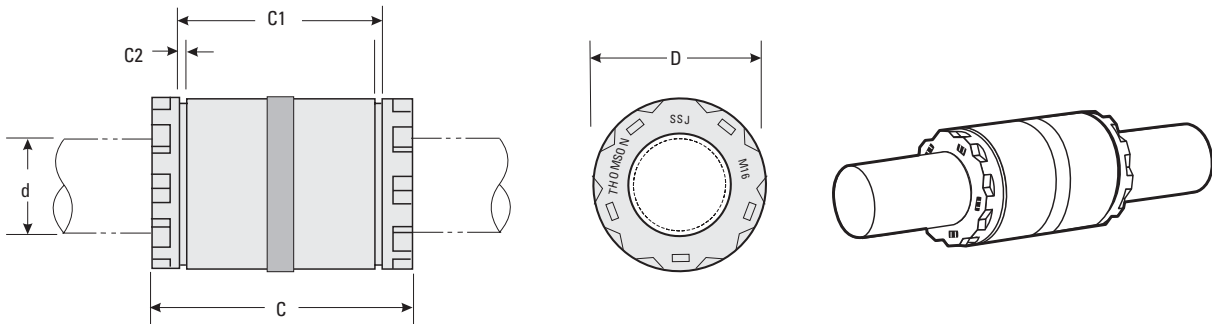

Designed to be used for new or existing JIS (Japanese Industrial Standard) designs

Part Number			Dimensions (mm)					Number of Ball Tracks	Mass (kg)	Dynamic Load $W^{(1)(3)}$ (N)	Load Limit $W_0^{(2)(3)}$ (N)
Without Integral Wipers	With One Integral Wiper	With Two Integral Wiper	Nominal Linear Race Dia. d	C h14	C1 h13	C2 min.	Nominal Housing Bore Dia. D <sup>(2)</sup>				
SSJM16	SSJM16W	SSJM16WW	16	37	26.5	1.60	28	10	.030	2200	2400
SSJM20	SSJM20W	SSJM20WW	20	42	30.5	1.60	32	10	.066	4000	4400
SSJM25	SSJM25W	SSJM25WW	25	59	41	1.85	40	10	.133	6700	7300
SSJM30	SSJM30W	SSJM30WW	30	64	44.5	1.85	45	10	.202	8300	9100
SSJM40	SSJM40W	SSJM40WW	40	80	60.5	2.10	60	10	.392	13700	15000

(1) For rated travel life of 100 km. For longer travel lives, reduce load to  $\ast(100/L)^{0.33}$  where L (km) is the required travel life. Do not exceed the Dynamic Load Rating for travel life of less than 100 km.

(2) The Load Limit is the maximum load that may be applied to a bearing/shaft. It is important to analyze the application so that peak and/or shock do not exceed the Load Limit.

(3) The load capacities W and Wq are valid for a resultant load applied at 90° with the ball tracks oriented as shown in the polar graphs below. If the resultant acts along another direction, the appropriate multiplicative correction factor  $K_{\theta}$  should be applied to W and Wq respectively. Open type bearings have reduced load capacities when used in pull-off situations.

(4) Refer to Table 1 to find the diametral tolerance between the LinearRace and Super Smart Ball Bushing bearing for bearing installation in housing H7 or J7 tolerance.

NOTE: For part number description and specifications, see page 134.

NOTE: External seals and retaining are available. See page 173 for specifications.

NOTE: For additional technical information, see the Engineering section beginning on page 256.

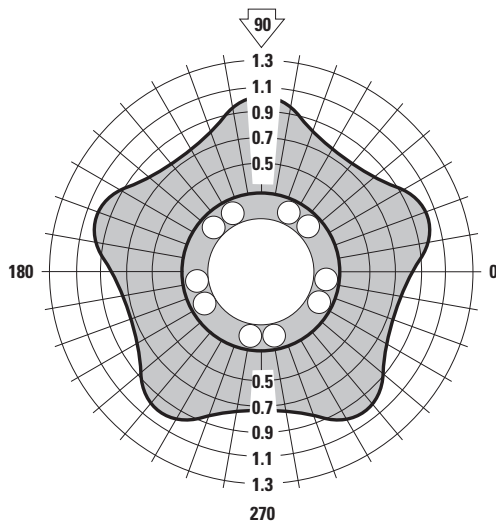

SSJM16  
SSJM20  
SSJM25  
SSJM30  
SSJM40

# Super Smart Ball Bushing Bearings - JIS Specifications (Open Type)

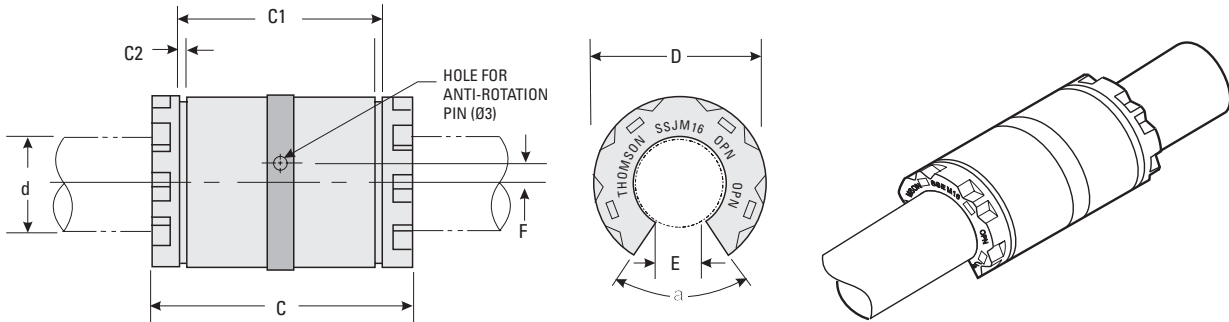

Designed to be used for new or existing JIS (Japanese Industrial Standard) designs

Part Number			Dimensions (mm)					E min.	a (deg)	Number of Ball Tracks	Mass (kg)	Dynamic Load $W^{(1)(3)}$ (N)	Load Limit $W_0^{(2)(3)}$ (N)
Without Integral Wipers	With One Integral Wiper	With Two Integral Wiper	Nominal LinearRace Dia. d	C h14	C1 h13	C2 min.	Nominal Housing Bore Dia. D <sup>(2)</sup>						
SSJM160PN	SSJM160PNW	SSJM160PNWW	16	37	26.5	1.60	28	11	80	8	.023	2200	2400
SSJM200PN	SSJM200PNW	SSJM200PNWW	20	42	30.5	1.60	32	11	60	8	.054	4000	4400
SSJM250PN	SSJM250PNW	SSJM250PNWW	25	59	41	1.85	40	12	50	8	.107	6700	7300
SSJM300PN	SSJM300PNW	SSJM300PNWW	30	64	44.5	1.85	45	15	50	8	.163	8300	9100
SSJM400PN	SSJM400PNW	SSJM400PNWW	40	80	60.5	2.10	60	20	50	8	.315	13700	15000

- (1) For rated travel life of 100 km. For longer travel lives, reduce load to  $\bullet(100/L)^{0.33}$  where L (km) is the required travel life. Do not exceed the Dynamic Load Rating for travel life of less than 100 km.
  - (2) The Load Limit is the maximum load that may be applied to a bearing/shaft. It is important to analyze the application so that peak and/or shock do not exceed the Load Limit.
  - (3) The load capacities W and  $W_0$  are valid for a resultant load applied at 90° with the ball tracks oriented as shown in the polar graphs below. If the resultant acts along another direction, the appropriate multiplicative correction factor  $K_\theta$  should be applied to W and  $W_0$  respectively. Open type bearings have reduced load capacities when used in pull-off situations.
  - (4) Refer to Table 1 to find the diametral tolerance between the LinearRace and Super Smart Ball Bushing bearing for bearing installation in housing having either a H7 or J7 tolerance.
- NOTE: For part number description and specifications, see page 134.  
 NOTE: External seals and retaining are available. See page 173 for specifications.  
 NOTE: For additional technical information, see the Engineering section beginning on page 256.

Table 1 – Standard Dimensional Clearances

Nominal LinearRace® Dia. d (mm)	Nominal Housing Bore Diameter d (mm)	Dimensional Clearance	
		Housing Bore H7 (µm)	Housing Bore J7 (µm)
16	28	+33 +8	+24 -1
20	32	+39 +9	+28 -2
25	40	+39 +9	+28 -2
30	45	+39 +9	+28 -2
40	60	+44 +11	+35 -1

For Super Smart Ball Bushing Bearings mounted in a housing and with LinearRace shafts, h6 tolerances

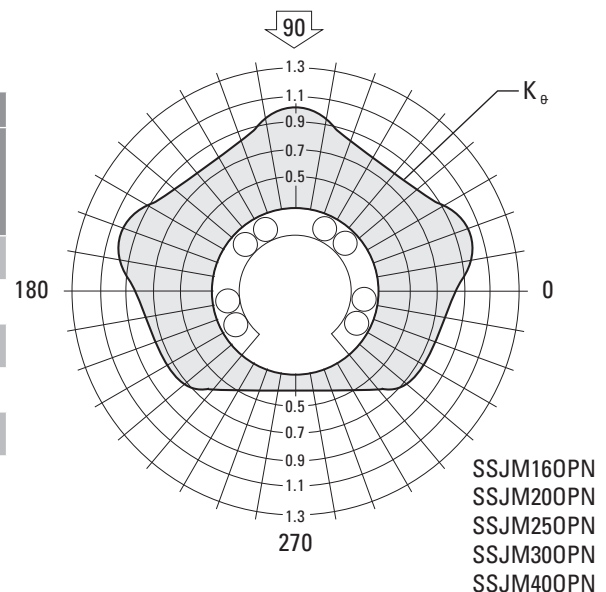



# Application

## Cam-Actuated Part Transfer Mechanism for Multiple-Transfer Press

### Objective

Improve production rate and increase the service life of a transfer table mechanism.

### Solution

Replace the conventional linear bearings with adjustable Super Smart twin pillow blocks.

### Products Specified

- 2 - SSETWNAM20DD (Super Smart Twin Pillow Blocks)
- 4 - ASBM20 (Shaft support blocks) Blocks
- 2 - 20 MM CTL X 600 mm 60 Case® LinearRace® Shaft

### Benefits

The table achieved maximum cycle efficiency by reducing costly downtime and improving service life. Bearing life is increased from 1 to 8 years.

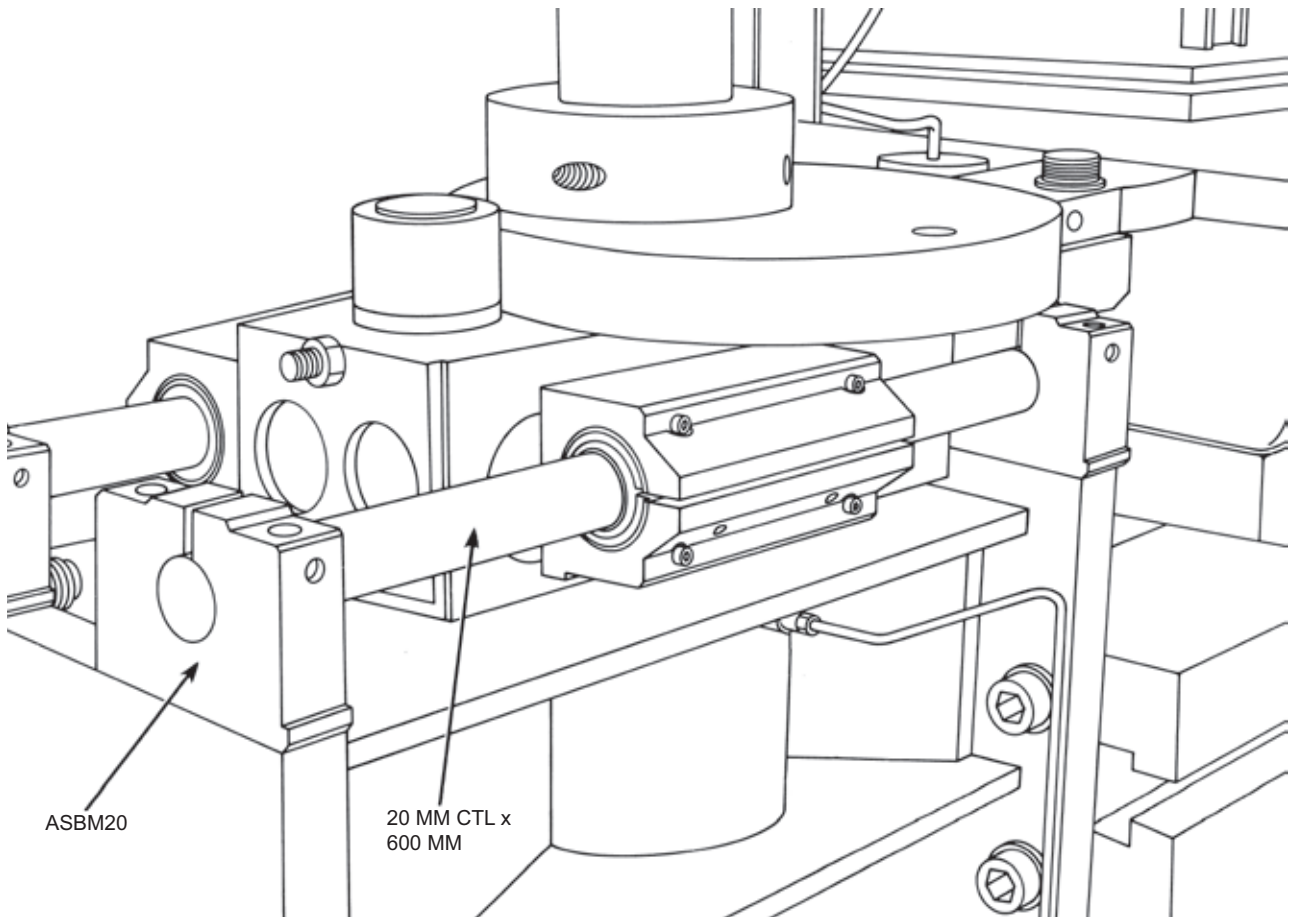

## X-Y Inspection System

### Objective

Accurately position an inspection probe of an X-Y system over small electronic components.

### Solution

Design an X-Y system with Super Smart Ball Bushing® pillow blocks to provide accurate and repeatable movement of the test probe. Utilize Thomson linear motion systems on the Y-axis to reduce cost and installation time.

### Benefits

Outstanding positioning accuracy and repeatability was provided by the adjustable pillow blocks and ball screws. The use of a pre-engineered, pre-assembled linear motion system on the Y-axis saved valuable design and assembly time.

### Products Specified

#### X-axis

- 2 - SSETWAM16DD (Super Smart Twin pillow blocks)
- 4 - ASBM16 (Shaft support blocks)
- 2 - 16 MM CTL X 600 MM (60 Case LinearRace shaft)
- 2 - 12 x5 Thomson ball screw assemblies

#### Y-axis

- 1 - 2CAM12 (pre-assembled linear motion system)
- 1 - 12 x5 Thomson ball screw assembly

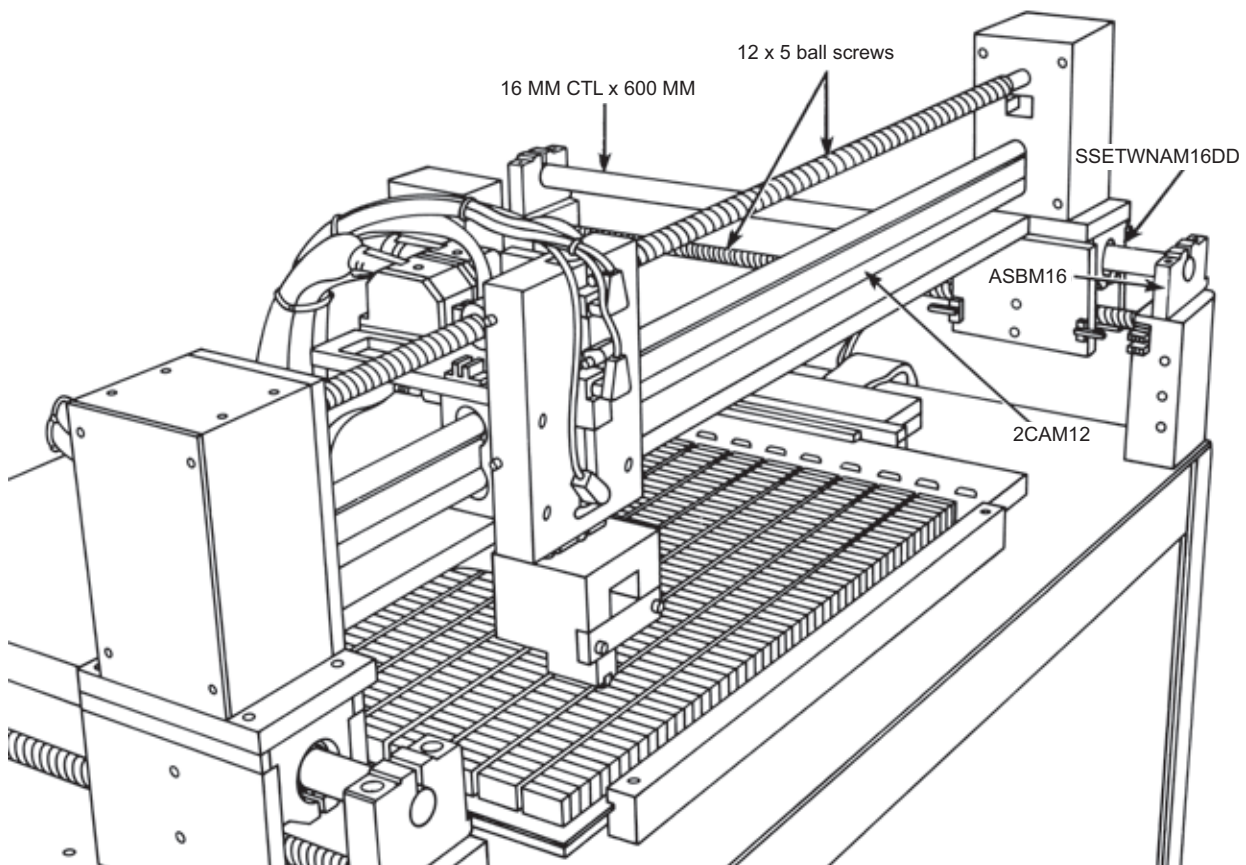



## Super Smart Pillow Blocks

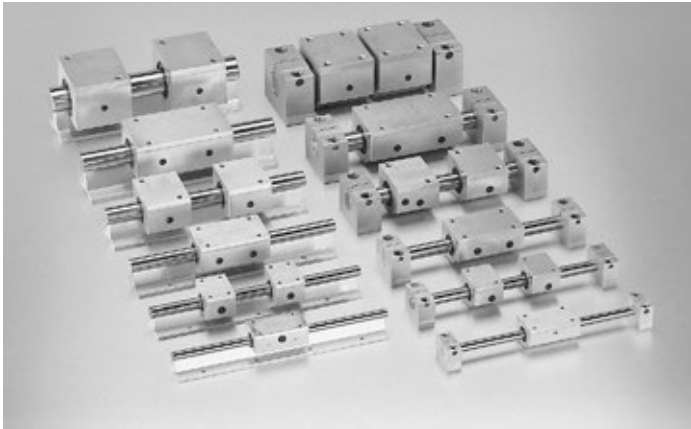

### Thomson Pillow Blocks with factory-installed Super Smart Ball Bushing® Bearings offer:

- Up to six times the load capacity or 216 times the travel life and five times the LinearRace® shaft life when replacing conventional linear bearing pillow blocks.
- Accelerations as high as 150 m/s<sup>2</sup> and steady state travel speeds up to 3 m/s without the derating factors commonly required with linear guides.
- Replaceable bearing components for quick, cost-effective machine maintenance and minimal downtime.
- Standard, double-acting, integral seals at both ends which keep out dirt, grit and other contaminants, retain lubrication and maximize bearing life.
- Adjustable, closed and open styles.
- Lubrication hole for easy maintenance.
- Tapped or thru hole mounting configuration for ease of installation.
- Twin version with two Super Smart Ball Bushing Bearings providing twice the load capacity or eight times more travel life than the single version.
- A single bearing version that self aligns in all directions, minimizing installation time and cost.

Note: See page 133 for information on Thomson Super Smart Ball Bushing Bearings.

# Part Number Description and Specification

## Super Smart Ball Bushing Bearings (Closed Type) for End-Supported Applications

### SSETWNM160PNWW-CR

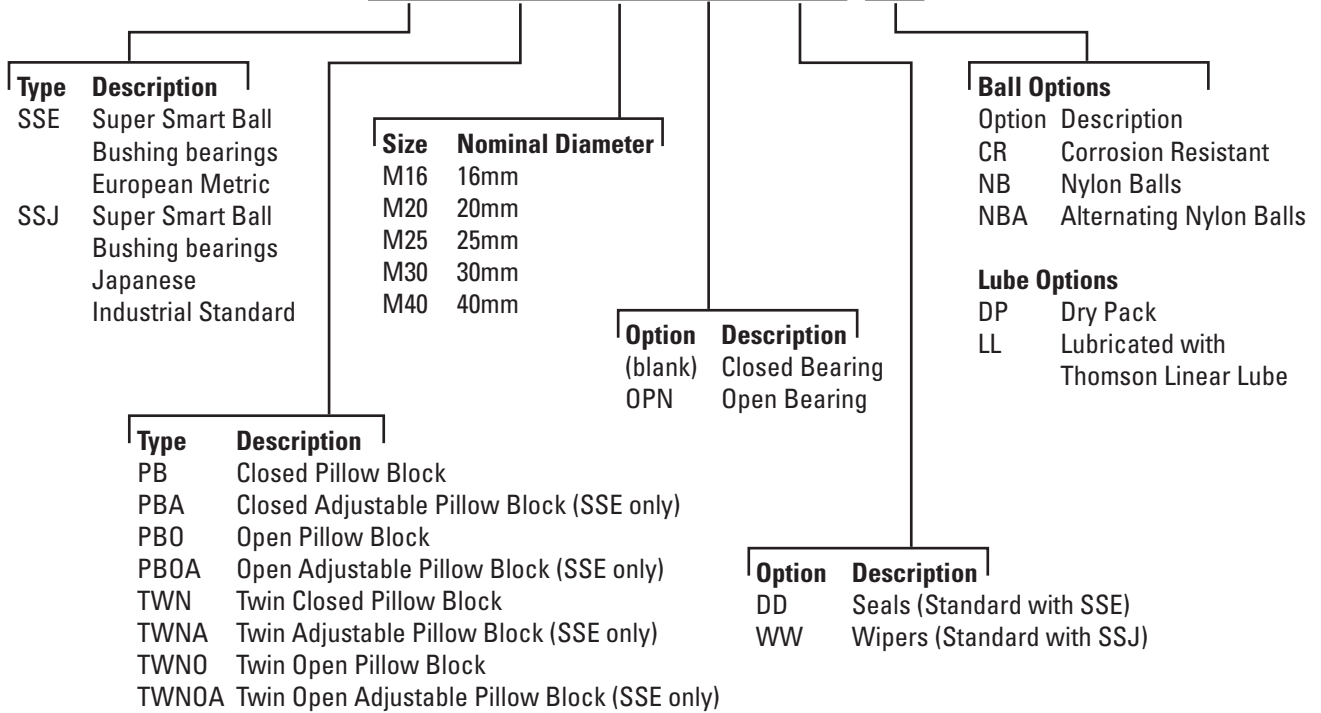

Not all options are available in all sizes.  
 See catalog pages or contact Thomson Customer Support for combination availability.  
 For additional information on bearing options, see page 267.



# Super Smart Pillow Blocks (Closed Type)

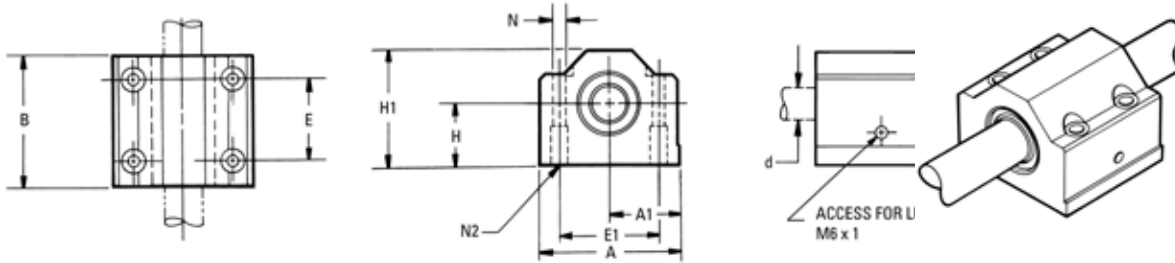

**Super Smart Pillow Blocks (Closed Type)** (Dimensions in mm)

Part Number	d <sup>(5)</sup>	H ± 0.020	H1	A	A1 ± 0.020	B	E ± 0.1	E1 ± 0.1	N Dia.	N2	Mass (kg)	Dynamic Load W <sub>d</sub> <sup>(1)(3)</sup> (N)	Load Limit W <sub>0</sub> <sup>(2)(3)</sup> (N)
SSEPBM16DD	16	22	42	53	26.5	43	26	40	5.3	M6	0.21	2200	2400
SSEPBM20DD	20	25	50	60	30.0	54	32	45	6.6	M8	0.35	4000	4400
SSEPBM25DD	25	30	60	78	39.0	67	40	60	8.4	M10	0.67	6700	7300
SSEPBM30DD	30	35	71	87	43.5	79	45	68	8.4	M10	0.99	8300	9100
SSEPBM40DD	40	45	91	108	54.0	91	58	86	10.5	M12	1.84	13700	15000

(1) For rated travel life of 100 km. For longer travel lives, reduce load to  $W \cdot (100/L)^{0.33}$  where L (km) is the required travel life. Do not exceed the Dynamic Load Rating for travel life of less than 100km.

(2) The Load Limit is the maximum load that may be applied to a bearing/shaft. It is important to analyze the application so the peak and/or shock loads do not exceed the Load Limit.

(3) For bearing diametral clearances, see Table 1.

NOTE: For part number description and specifications, see page 143.

NOTE: External seals and retaining rings are available. See page 173 for specifications.

NOTE: For additional technical information, see the Engineering section beginning on page 256.

**Table 1- Standard  
Diametral Clearances  
(Closed Type)**

Nominal Size d (mm)	Diametral Clearance (µm)
16	+26 +3
20	+30 +4
25	+30 +4
30	+30 +4
40	+35 +5

For Pillow Blocks used with LinearRace Shaft, h6 tolerance

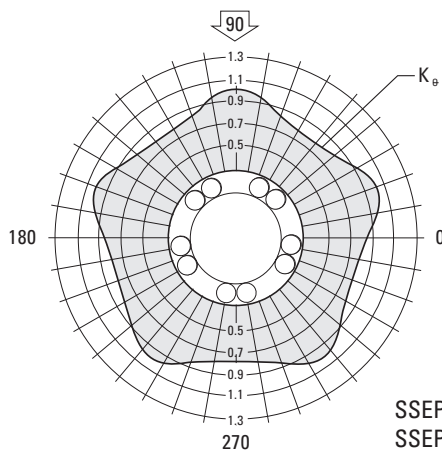

SSEPBM16DD  
SSEPBM20DD  
SSEPBM25DD  
SSEPBM30DD  
SSEPBM40DD

# Super Smart Pillow Blocks (Closed Adjustable Type)

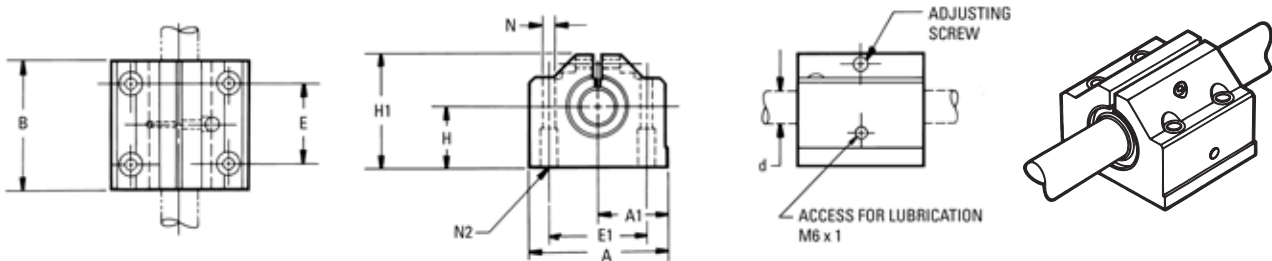

**Super Smart Pillow Blocks (Closed Adjustable Type)** (Dimensions in mm)

Part Number	d <sup>(5)</sup>	H ± 0.020	H1	A	A1 ± 0.020	B	E ± 0.1	E1 ± 0.1	N Dia.	N2	Mass (kg)	Dynamic Load W <sup>(1)(2)</sup> (N)	Load Limit W <sub>0</sub> <sup>(2)(4)</sup> (N)
SSEPAM16DD	16	22	42	53	26.5	43	26	40	5.3	M6	0.21	2200	2400
SSEPAM20DD	20	25	50	60	30.0	54	32	45	6.6	M8	0.35	4000	4400
SSEPAM25DD	25	30	60	78	39.0	67	40	60	8.4	M10	0.67	6700	7300
SSEPAM30DD	30	35	71	87	43.5	79	45	68	8.4	M10	0.99	8300	9100
SSEPAM40DD	40	45	91	108	54.0	91	58	86	10.5	M12	1.84	13700	15000

(4) The load capacities W and W<sub>0</sub> are valid for a resultant load applied at 90° with the ball tracks oriented as shown in the polar graphs below. If the resultant acts along another direction, the appropriate multiplicative correction factor, K<sub>φ</sub>, should be applied to W and W<sub>0</sub> respectively. Open type bearings have reduced load capacities when used in pull-off situations.

(5) Adjusted to nominal.

NOTE: For part number description and specifications, see page 143.

NOTE: External seals and retaining rings are available. See page 173 for specifications.

NOTE: For additional technical information, see the Engineering section beginning on page 256.

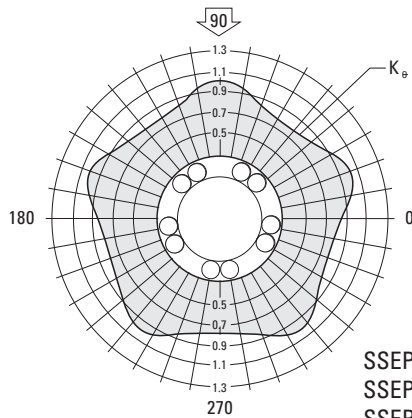

SSEPAM16DD  
SSEPAM20DD  
SSEPAM25DD  
SSEPAM30DD  
SSEPAM40DD



# Super Smart Pillow Blocks (Open Type)

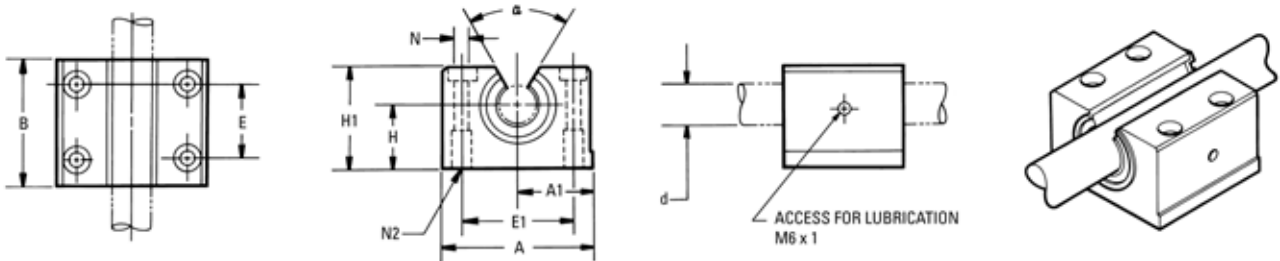

**Super Smart Pillow Blocks (Open Type)** (Dimensions in mm)

Part Number	d <sup>(5)</sup>	H ± 0.020	H1	A	A1 ± 0.020	B	E ± 0.1	E1 ± 0.1	N Dia.	N2	Angle α (deg)	Mass (kg)	Dynamic Load W <sub>d</sub> <sup>(1)(2)</sup> (N)	Load Limit W <sub>0</sub> <sup>(2)(4)</sup> (N)
SSEPBM16DD	16	22	35	53	26.5	43	26	40	5.3	M6	70	0.19	2200	2400
SSEPBM20DD	20	25	42	60	30.0	54	32	45	6.6	M8	50	0.30	4000	4400
SSEPBM25DD	25	30	51	78	39.0	67	40	60	8.4	M10	60	0.60	6700	7300
SSEPBM30DD	30	35	60	87	43.5	79	45	68	8.4	M10	55	0.93	8300	9100
SSEPBM40DD	40	45	77	108	54.0	91	58	86	10.5	M12	54	1.66	13700	15000

(1) For rated travel life of 100 km. For longer travel lives, reduce load to  $W \cdot (100/L)^{0.33}$  where L (km) is the required travel life. Do not exceed the Dynamic Load Rating for travel life of less than 100km.

(2) The Load Limit is the maximum load that may be applied to a bearing/shaft. It is important to analyze the application so that peak and/or shock loads do not exceed the Load Limit.

(3) For bearing diametral clearances, see Table 2.

NOTE: For part number description and specifications, see page 143.

NOTE: External seals and retaining rings are available. See page 173 for specifications.

NOTE: For additional technical information, see the Engineering section beginning on page 256.

**Table 2 - Standard Diametral Clearances (Open Type)**

Nominal Size d (mm)	Diametral Clearance (μm)
16	+26 +3
20	+30 +4
25	+30 +4
30	+30 +4
40	+35 +5

For Pillow Blocks used with LinearRace Shaft, h6 tolerance

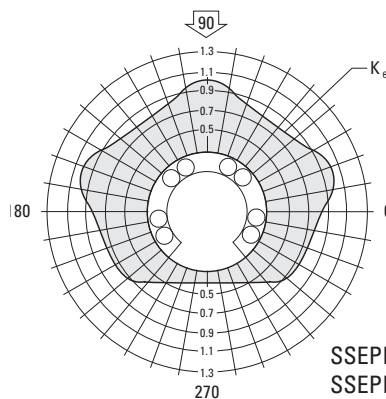

SSEPBM16DD  
SSEPBM20DD  
SSEPBM25DD  
SSEPBM30DD  
SSEPBM40DD

# Super Smart Pillow Blocks (Open Adjustable Type)

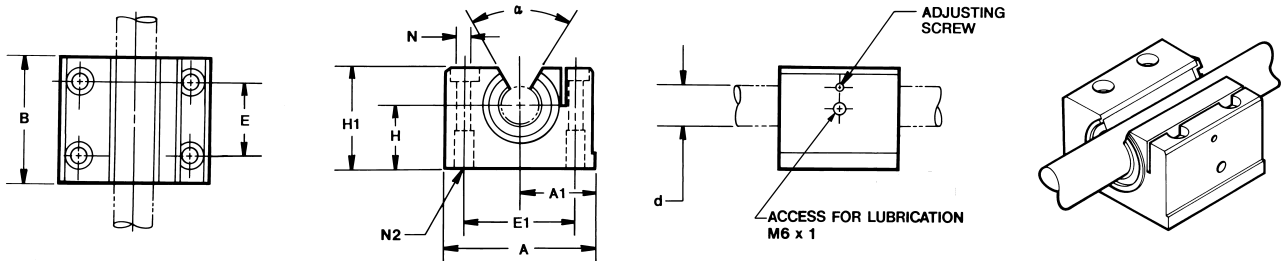

**Super Smart Pillow Blocks (Open Adjustable Type)** (Dimensions in mm)

Part Number	d <sup>(5)</sup>	H ± 0.020	H1	A	A1 ± 0.020	B	E ± 0.1	E1 ± 0.1	N Dia.	N2	Angle α (deg)	Mass (kg)	Dynamic Load W <sup>(1)(2)</sup> (N)	Load Limit W <sub>0</sub> <sup>(2)(4)</sup> (N)
SSEPBOAM16DD	16	22	35	53	26.5	43	26	40	5.3	M6	70	0.19	2200	2400
SSEPBOAM20DD	20	25	42	60	30.0	54	32	45	6.6	M8	50	0.30	4000	4400
SSEPBOAM25DD	25	30	51	78	39.0	67	40	60	8.4	M10	60	0.60	6700	7300
SSEPBOAM30DD	30	35	60	87	43.5	79	45	68	8.4	M10	55	0.93	8300	9100
SSEPBOAM40DD	40	45	77	108	54.0	91	58	86	10.5	M12	54	1.66	13700	15000

(4) The load capacities W and W<sub>0</sub> are valid for a resultant load applied at 90° with the ball tracks oriented as shown in the polar graphs below. If the resultant acts along another direction, the appropriate multiplicative correction factor, K<sub>φ</sub>, should be applied to W and W<sub>0</sub> respectively. Open type bearings have reduced load capacities when used in pull-off situations.

(5) Adjusted to nominal.

NOTE: For part number description and specifications, see page 143.

NOTE: External seals and retaining rings are available. See page 173 for specifications.

NOTE: For additional technical information, see the Engineering section beginning on page 256.

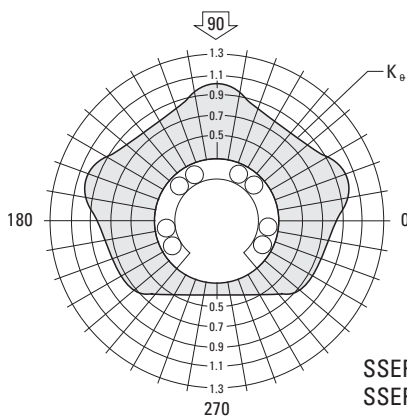

SSEPBOAM16DD  
SSEPBOAM20DD  
SSEPBOAM25DD  
SSEPBOAM30DD  
SSEPBOAM40DD



# Super Smart Twin Pillow Blocks (Closed Type)

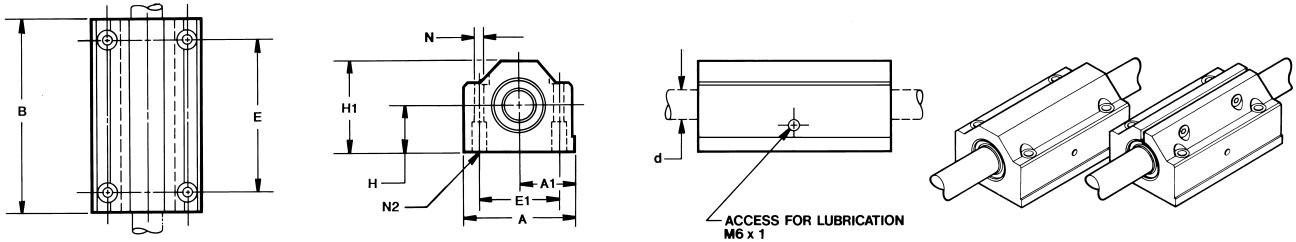

**Super Smart Twin Pillow Blocks (Closed Type)** (Dimensions in mm)

Part Number	d <sup>(5)</sup>	H ± 0.020	H1	A	A1 ± 0.020	B	E ± 0.1	E1 ± 0.1	N Dia.	N2	Mass (kg)	Dynamic Load W <sub>0</sub> <sup>(1)(2)</sup> (N)	Load Limit W <sub>0</sub> <sup>(2)(4)</sup> (N)
SSETWNM16DD	16	22	42	53	26.5	84	64	40	5.3	M6	0.41	4400	4800
SSETWNM20DD	20	25	51	60	30.0	104	76	45	6.6	M8	0.67	8000	8800
SSETWNM25DD	25	30	60	78	39.0	130	94	60	8.4	M10	1.24	13400	14600
SSETWNM30DD	30	35	71	87	43.5	152	106	68	8.4	M10	1.94	16600	18200
SSETWNM40DD	40	45	91	108	54.0	176	124	86	10.5	M12	3.63	27400	30000

## (Closed Adjustable Type)

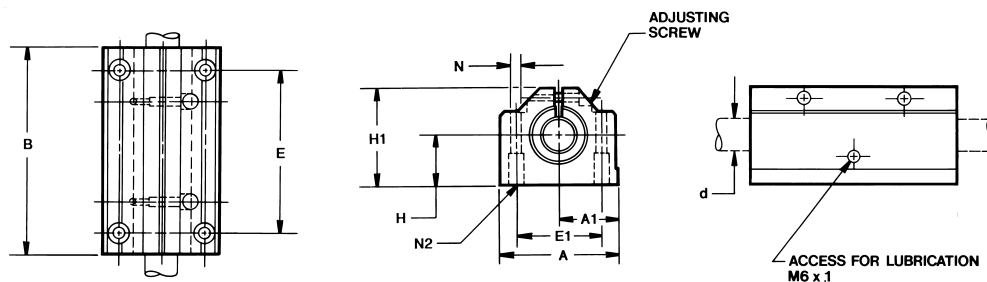

**Super Smart Twin Pillow Blocks (Closed Adjustable Type)** (Dimensions in mm)

Part Number	d <sup>(5)</sup>	H ± 0.020	H1	A	A1 ± 0.020	B	E ± 0.1	E1 ± 0.1	N Dia.	N2	Mass (kg)	Dynamic Load W <sub>0</sub> <sup>(1)(2)</sup> (N)	Load Limit W <sub>0</sub> <sup>(2)(4)</sup> (N)
SSETWNAM16DD	16	22	42	53	26.5	84	64	40	5.3	M6	0.41	4400	4800
SSETWNAM20DD	20	25	50	60	30.0	104	76	45	6.6	M8	0.67	8000	8800
SSETWNAM25DD	25	30	60	78	39.0	130	94	60	8.4	M10	1.24	13400	14600
SSETWNAM30DD	30	35	71	87	43.5	152	106	68	8.4	M10	1.94	16600	18200
SSETWNAM40DD	40	45	91	108	54.0	176	124	86	10.5	M12	3.63	27400	30000

See footnotes (1) (2) (3) (4) (5) on pages 146-147. For diametral clearances, see single versions of pillow block.

NOTE: For part number description and specifications, see page 143.

NOTE: External seals and retaining rings are available. See page 173 for specifications.

NOTE: For additional technical information, see the Engineering section beginning on page 256.

# Super Smart Twin Pillow Blocks (Open Type)

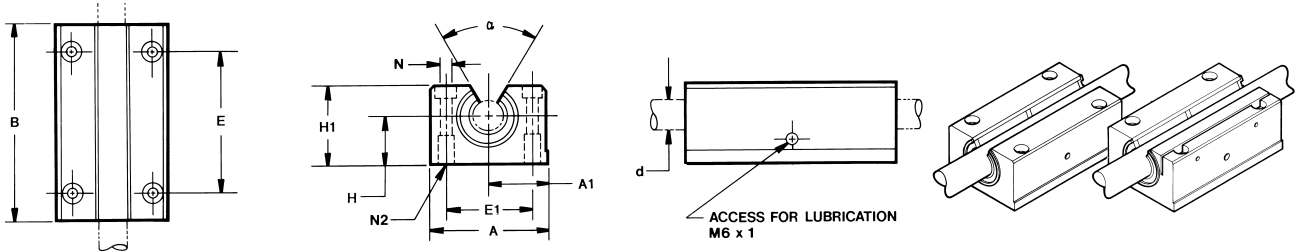

**Super Smart Twin Pillow Blocks (Open Type)** (Dimensions in mm)

Part Number	d <sup>(5)</sup>	H ± 0.020	H1	A	A1 ± 0.020	B	E ± 0.1	E1 ± 0.1	N Dia.	N2	Angle $\alpha$ (deg)	Mass (kg)	Dynamic Load W <sup>(1)(2)</sup> (N)	Load Limit W <sub>0</sub> <sup>(2)(4)</sup> (N)
SSETWNOM16DD	16	22	35	53	26.5	84	64	40	5.3	M6	70	0.37	4400	4800
SSETWNOM20DD	20	25	41	60	30.0	104	76	45	6.6	M8	50	0.58	8000	8800
SSETWNOM25DD	25	30	50	78	39.0	130	94	60	8.4	M10	60	1.16	13400	14600
SSETWNOM30DD	30	35	60	87	43.5	152	106	68	8.4	M10	55	1.78	16600	18200
SSETWNOM40DD	40	45	77	108	54.0	176	124	86	10.5	M12	54	3.25	27400	30000

## (Open Adjustable Type)

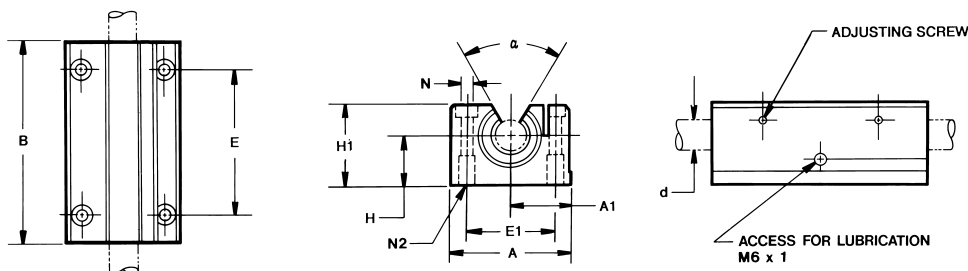

**Super Smart Twin Pillow Blocks (Open Adjustable Type)** (Dimensions in mm)

Part Number	d <sup>(5)</sup>	H ± 0.020	H1	A	A1 ± 0.020	B	E ± 0.1	E1 ± 0.1	N Dia.	N2	Angle $\alpha$ (deg)	Mass (kg)	Dynamic Load W <sup>(1)(2)</sup> (N)	Load Limit W <sub>0</sub> <sup>(2)(4)</sup> (N)
SSETWNOAM16DD	16	22	35	53	26.5	84	64	40	5.3	M6	70	0.37	4400	4800
SSETWNOAM20DD	20	25	41	60	30.0	104	76	45	6.6	M8	50	0.58	8000	8800
SSETWNOAM25DD	25	30	50	78	39.0	130	94	60	8.4	M10	60	1.16	13400	14600
SSETWNOAM30DD	30	35	60	87	43.5	152	106	68	8.4	M10	55	1.78	16600	18200
SSETWNOAM40DD	40	45	77	108	54.0	176	124	86	10.5	M12	54	3.25	27400	30000

See footnotes (1) (2) (3) (4) (5) on pages 146-147. For diametral clearances, see single versions of pillow block.

NOTE: For part number description and specifications, see page 143.

NOTE: External seals and retaining rings are available. See page 173 for specifications.

NOTE: For additional technical information, see the Engineering section beginning on page 256.



# Super Smart Pillow Blocks - JIS Specifications (Closed Type)

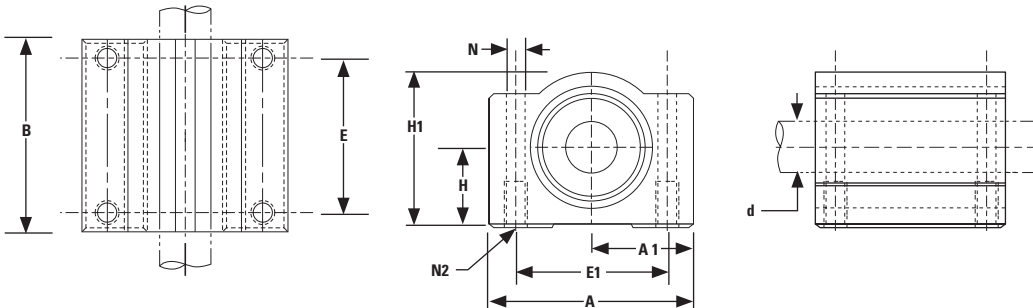

Designed to be used for new or existing JIS (Japanese Industrial Standard) designs (Dimensions in mm)

Part Number	d <sup>(5)</sup>	H ± 0.020	H1	A	A1 ± 0.020	B	E ± 0.1	E1 ± 0.1	N Dia.	N2	Mass (kg)	Dynamic Load W <sup>(1)(3)</sup> (N)	Load Limit W <sub>0</sub> <sup>(2)(3)</sup> (N)
SSJPBM16	16	19	37	50	25	44	34	36	4.3	M5	0.21	2200	2400
SSJPBM20	20	21	41	54	27	50	40	40	5.2	M6	0.35	4000	4400
SSJPBM25	25	26	51	76	38	67	50	54	7	M8	0.67	6700	7300
SSJPBM30	30	30	57	78	39	72	58	58	7	M8	0.99	8300	9100
SSJPBM40	40	40	75	102	51	90	60	80	8.7	M10	1.84	13700	15000

(1) For rated travel life of 100 km. For longer travel lives, reduce load to  $W \cdot (100/L)^{0.33}$  where L (km) is the required travel life. Do not exceed the Dynamic Load Rating for travel life of less than 100km.

(2) The Load Limit is the maximum load that may be applied to a bearing/shaft. It is important to analyze the application so the peak and/or shock loads do not exceed the Load Limit.

(3) For bearing diametral clearances, see Table 1.

NOTE: For part number description and specifications, see page 143.

NOTE: External seals and retaining rings are available. See page 173 for specifications.

NOTE: For additional technical information, see the Engineering section beginning on page 256.

**Table 1- Standard  
Diametral Clearances  
(Closed Type)**

Nominal Size d (mm)	Diametral Clearance (µm)
16	+26 +3
20	+30 +4
25	+30 +4
30	+30 +4
40	+35 +5

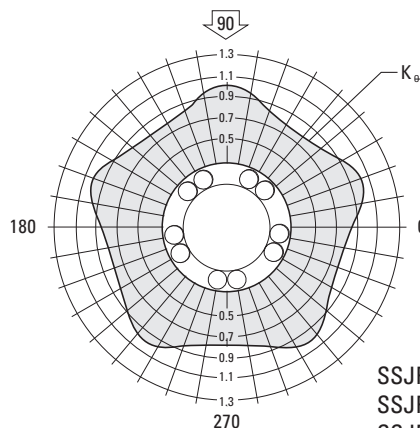

SSJPBM16  
SSJPBM20  
SSJPBM25  
SSJPBM30  
SSJPBM40

For pillow blocks used with  
LinearRace® shaft, h6 tolerance

# Super Smart Pillow Blocks - JIS Specifications (Open Type)

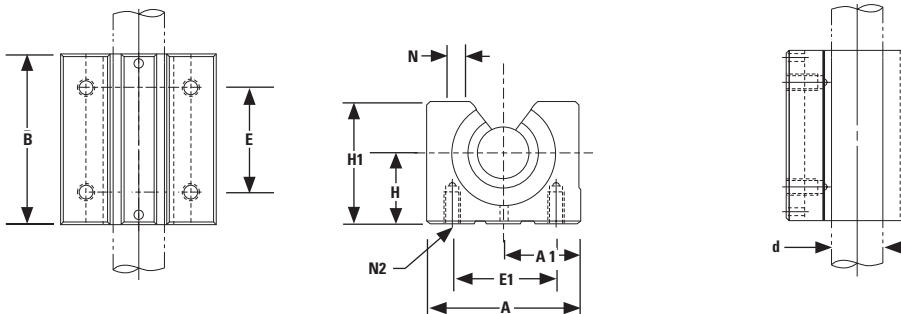

Designed to be used for new or existing JIS (Japanese Industrial Standard) designs (Dimensions in mm)

Part Number	d <sup>(5)</sup>	H ± 0.020	H1	A	A1 ± 0.020	B	E ± 0.1	E1 ± 0.1	N Dia.	N2	Mass (kg)	Dynamic Load W <sup>(1)(2)</sup> (N)	Load Limit W <sub>0</sub> <sup>(2)(4)</sup> (N)
SSJPBOM16	16	20	33	45	22.5	45	30	32	5	M5	0.19	2200	2400
SSJPBOM20	20	23	38	48	24	50	35	35	6	M6	0.30	4000	4400
SSJPBOM25	25	27	47	60	30	65	40	40	6	M6	0.60	6700	7300
SSJPBOM30	30	33	55	70	35	70	50	50	8	M8	0.93	8300	9100
SSJPBOM40	40	42	72	90	45	90	65	65	10	M10	1.66	13700	15000

(1) For rated travel life of 100 km. For longer travel lives, reduce load to  $W \cdot (100/L)^{0.33}$  where L (km) is the required travel life. Do not exceed the Dynamic Load Rating for travel life of less than 100km.

(2) The Load Limit is the maximum load that may be applied to a bearing/shaft. It is important to analyze the application so that peak and/or shock loads do not exceed the Load Limit.

(3) For bearing diametral clearances, see Table 2.

NOTE: For part number description and specifications, see page 143.

NOTE: External seals and retaining rings are available. See page 173 for specifications.

NOTE: For additional technical information, see the Engineering section beginning on page 256.

**Table 2 - Standard Diametral Clearances (Open Type)**

Nominal Size d (mm)	Diametral Clearance (µm)
16	+26 +3
20	+30 +4
25	+30 +4
30	+30 +4
40	+35 +5

For pillow blocks used with LinearRace shaft, h6 tolerance

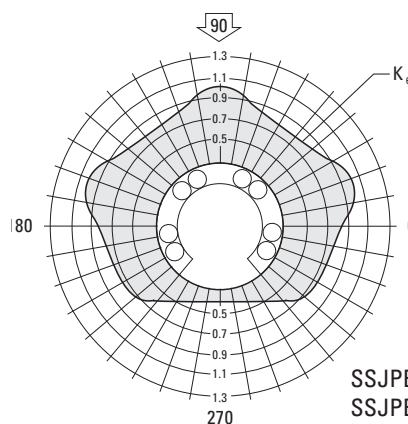

SSJPBOM16  
SSJPBOM20  
SSJPBOM25  
SSJPBOM30  
SSJPBOM40



# Super Smart Twin Pillow Blocks - JIS Specifications (Closed Type)

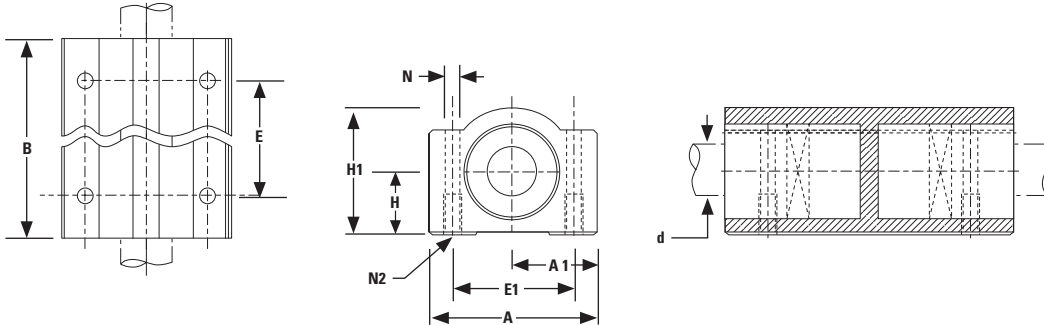

Designed to be used for new or existing JIS (Japanese Industrial Standard) designs (Dimensions in mm)

Part Number	d <sup>(5)</sup>	H ± 0.020	H1	A	A1 ± 0.020	B	E ± 0.1	E1 ± 0.1	N Dia.	N2	Mass (kg)	Dynamic Load W <sub>0</sub> <sup>(1)(2)</sup> (N)	Load Limit W <sub>0</sub> <sup>(2)(4)</sup> (N)
SSJTWNM16	16	19	37	50	25	85	60	36	4.3	M5	0.41	4400	4800
SSJTWNM20	20	21	41	54	27	96	70	40	5.2	M6	0.67	8000	8800
SSJTWNM25	25	26	51	76	38	130	100	54	7	M8	1.24	13400	14600
SSJTWNM30	30	30	57	78	39	140	110	58	7	M8	1.94	16600	18200
SSJTWNM40	40	40	75	102	51	175	140	80	8.7	M10	3.63	27400	30000

## (Open Type)

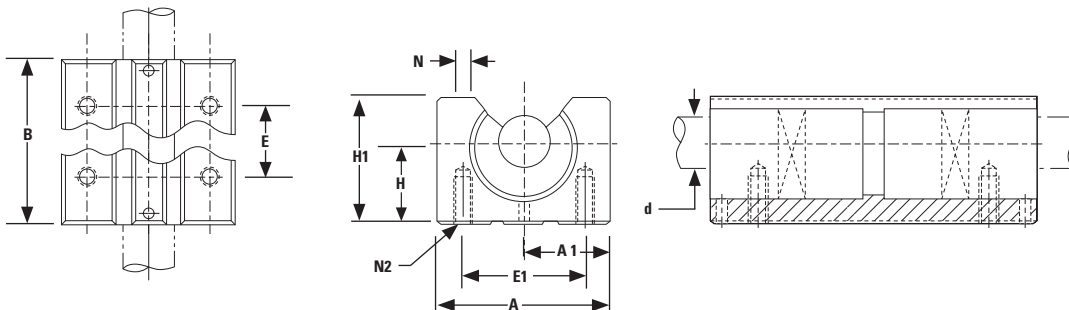

Designed to be used for new or existing JIS (Japanese Industrial Standard) designs (Dimensions in mm)

Part Number	d <sup>(5)</sup>	H ± 0.020	H1	A	A1 ± 0.020	B	E ± 0.1	E1 ± 0.1	N Dia.	N2	Mass (kg)	Dynamic Load W <sub>0</sub> <sup>(1)(2)</sup> (N)	Load Limit W <sub>0</sub> <sup>(2)(4)</sup> (N)
SSJTWNOM16	16	20	33	45	27.5	85	60	32	5	M5	0.41	4400	4800
SSJTWNOM20	20	23	38	48	24	96	70	35	6	M6	0.67	8000	8800
SSJTWNOM25	25	27	47	60	30	130	100	40	6	M6	1.24	13400	14600
SSJTWNOM30	30	33	55	70	35	140	110	50	8	M8	1.94	16600	18200
SSJTWNOM40	40	42	72	90	45	175	140	65	10	M10	3.63	27400	30000

See footnotes (1) (2) (3) on pages 150-151. For diametral clearances, see single versions of pillow block.

NOTE: For part number description and specifications, see page 143.

NOTE: External seals and retaining rings are available. See page 173 for specifications.

NOTE: For additional technical information, see the Engineering section beginning on page 256.

# Application

## Punch Press

### Objective

Reduce deflection of plate loader to minimize scrap and improve cycle speed.

### Solution

Replace super type linear bearings with Super Smart pillow blocks and Smart Rail assemblies to improve accuracy, load capacity, service life, efficiency and reduce downtime.

### Products Specified

- 4 - SSEPBOAM25DD (Super Smart Pillow Blocks)
- 2 - LSRAM25 x 900 mm Smart Rail assemblies

### Benefits

By retrofitting with Super Smart Pillow Blocks, machine productivity increased 700%. Smart Rail assemblies provided reduced deflection during plate loading. The retrofit required minimum downtime due to the pillow blocks' ease of installation.

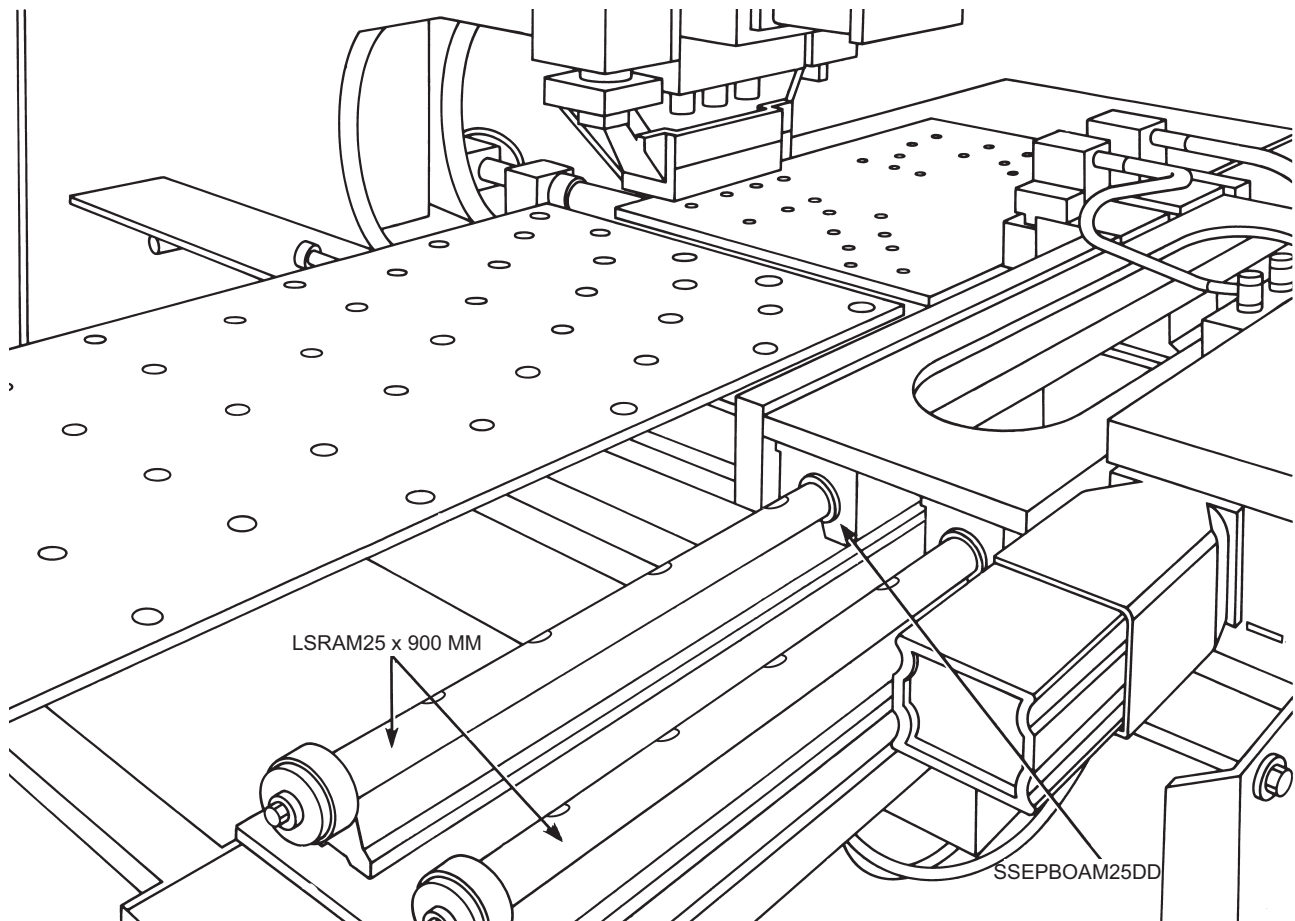



## MultiTrac® Ball Bushing® Bearings



### Thomson MultiTrac Ball Bushing Bearings offer:

- Patented, multiple-track design with up to twice the load-carrying capacity, or eight times the life, of conventional linear bearings.
- Rigid design for minimal deflection, assuring accurate, precise positioning.
- Coefficient of friction as low as 0.001.
- Patented ball control technology, which eliminates binding and chatter (stick-slip) common to high-friction, plain bushings and sliding-way bearings.
- RoundRail Advantage which, combined with the advanced MultiTrac Ball Bushing Bearing design, eliminates the need for the derating factors commonly required with square rail linear guides.
- Steady state speeds up to 3 m/s and accelerations up to 150 m/s<sup>2</sup>, without the use of derating factors.
- Wear-resistant, engineered-polymer retainers to reduce inertia and noise levels.
- Adjustable, closed and open configurations.
- Stainless steel (440C) option available in all sizes for corrosive environments.

## Part Number Description and Specification

### Super Smart Ball Bushing Bearings (Closed Type) for End-Supported Applications

#### MAM160PNWWSS

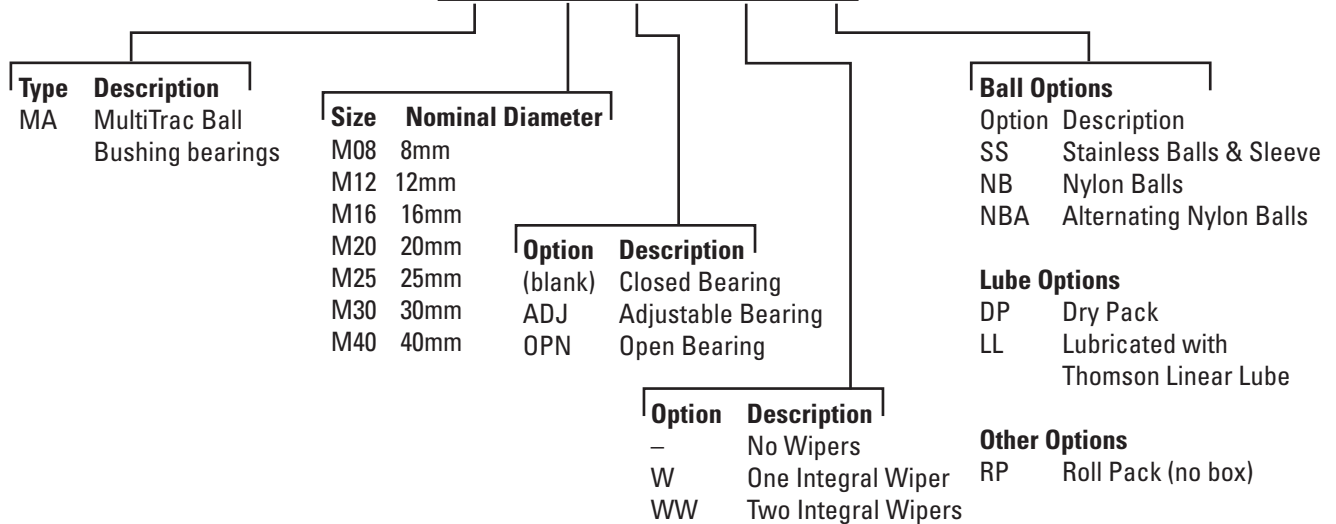

Not all options are available in all sizes.

See catalog pages or contact Thomson Customer Support for combination availability.

For additional information on bearing options, see page 267.



# MultiTrac® Ball Bushing® Bearings (Closed Type)

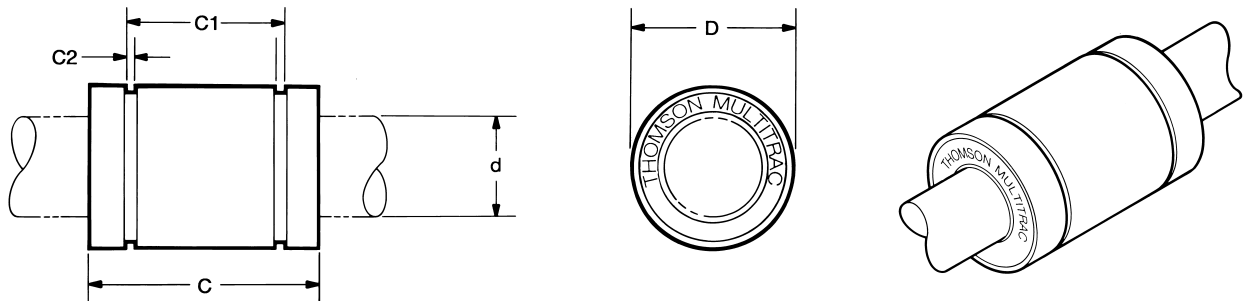

## MultiTrac Ball Bushing Linear Bearings (Closed Type) (Dimensions in mm)

Part Number			d <sup>(4)</sup>	D	C h14	C1 H13	C2 min.	Number of ball tracks	Mass (kg)	Dynamic Load W <sup>(1)(3)</sup> (N)	Load Limit W <sub>0</sub> <sup>(2)(3)</sup> (N)
Without Integral Wipers	With one Integral Wiper	With two Integral Wipers									
MAM08	MAM08W	MAM08WW	8	16	25	16.2	1.10	4	0.02	180	330
MAM12	MAM12W	MAM12WW	12	22	32	22.6	1.30	5	0.04	350	880
MAM16	MAM16W	MAM16WW	16	26	36	24.6	1.30	8	0.06	550	1300
MAM20	MAM20W	MAM20WW	20	32	45	31.2	1.60	8	0.11	1000	2360
MAM25	MAM25W	MAM25WW	25	40	58	43.7	1.85	8	0.20	1980	5100
MAM30	MAM30W	MAM30WW	30	47	68	51.7	1.85	8	0.33	2060	5800
MAM40	MAM40W	MAM40WW	40	62	80	60.3	2.15	8	0.63	3820	9250

(1) For rated travel life of 100 km. For longer travel lives, reduce load to  $W \cdot (100/L)^{0.33}$  where L (km) is the required travel life. Do not exceed the Dynamic Load Rating for travel life of less than 100 km.

(2) The load limit is the maximum load that may be applied to a bearing/shaft. It is important to analyze the application so that peak and/or shock loads do not exceed the Load Limit.

(3) For diametral clearance, see Table 1.

NOTE: For part number description and specifications, see page 155.

NOTE: External seals and retaining rings are available. See page 173 for specifications.

NOTE: For additional technical information, see the Engineering section beginning on page 256.

**Table 1 - Standard Diametral Clearances Closed Type**

Nominal Size d (mm)	Diametral Clearance (µm)
8	+15 +3
12	+19 +3
16	+19 +3
20	+22 +4
25	+22 +4
30	+22 +4
40	+27 +5

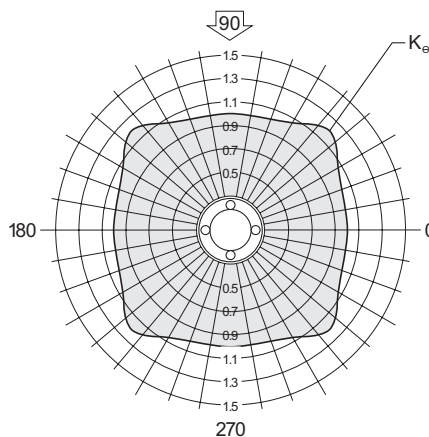

MAM16                      MAM20ADJ  
MAM20                      MAM25ADJ  
MAM25                      MAM30ADJ  
MAM30                      MAM40ADJ  
MAM40  
MAM16ADJ

For closed type bearings with LinearRace® shaft, h6 tolerance

# MultiTrac Ball Bushing Linear Bearings (Closed adjustable type)

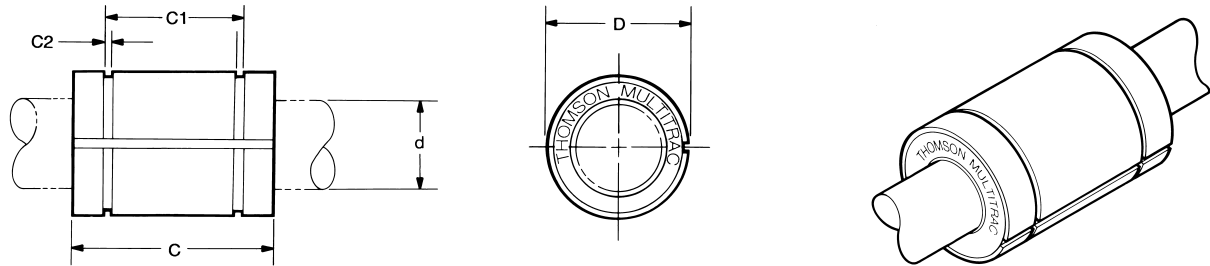

**MultiTrac Ball Bushing Linear Bearings (Closed Adjustable Type)** (Dimensions in mm)

Part Number			d <sup>(4)</sup>	D	C h14	C1 H13	C2 min.	Number of ball tracks	Mass (kg)	Dynamic Load W <sup>(1)(3)</sup> (N)	Load Limit W <sub>0</sub> <sup>(2)(3)</sup> (N)
Without Integral Wipers	With one Integral Wiper	With two Integral Wipers									
MAM08ADJ	MAM08ADJW	MAM08ADJWW	8	16	25	16.2	1.10	4	0.002	180	330
MAM12ADJ	MAM12ADJW	MAM12ADJWW	12	22	32	22.6	1.30	6	0.04	350	880
MAM16ADJ	MAM16ADJW	MAM16ADJWW	16	26	36	24.6	1.30	8	0.06	550	1300
MAM20ADJ	MAM20ADJW	MAM20ADJWW	20	32	45	31.2	1.60	8	0.11	1000	2360
MAM25ADJ	MAM25ADJW	MAM25ADJWW	25	40	58	43.7	1.85	8	0.20	1980	5100
MAM30ADJ	MAM30ADJW	MAM30ADJWW	30	47	68	51.7	1.85	8	0.33	2060	5800
MAM40ADJ	MAM40ADJW	MAM40ADJWW	40	62	80	60.3	2.15	8	0.63	3820	9250

(4) The load capacities W and W<sub>q</sub> are valid for a resultant load applied at 90° with the ball tracks oriented as shown in the polar graphs below. If the resultant acts along another direction, the appropriate multiplicative correction factor K<sub>φ</sub> should be applied to W and W<sub>q</sub> respectively. Open type bearings have reduced load capacities when used in pull-off situations.

(5) Diametral fit-up is determined by the housing diameter. See Table 2.

NOTE: For part number description and specifications, see page 155.

NOTE: External seals and retaining rings are available. See page 173 for specifications.

NOTE: For additional technical information, see the Engineering section beginning on page 256.

**Table 2 -  
Standard Diametral Clearances  
Adjustable and Open Type**

Nominal Shaft Diameter d (mm)	Diametral Housing Bore H6 (µm)
8	+28 +7
12	+33 +9
16	+33 +9
20	+40 +10
25	+40 +10
30	+40 +10
40	+48 +12

For adjustable and open type bearings with LinearRace shaft, h6 tolerance

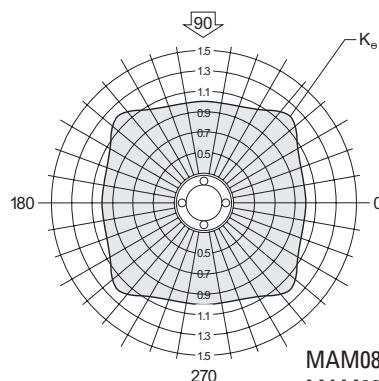
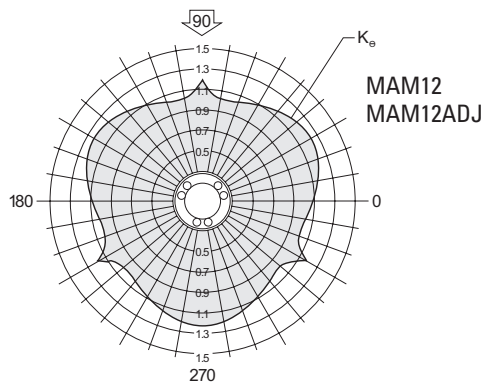



# MultiTrac® Ball Bushing® Bearings (Open Type)

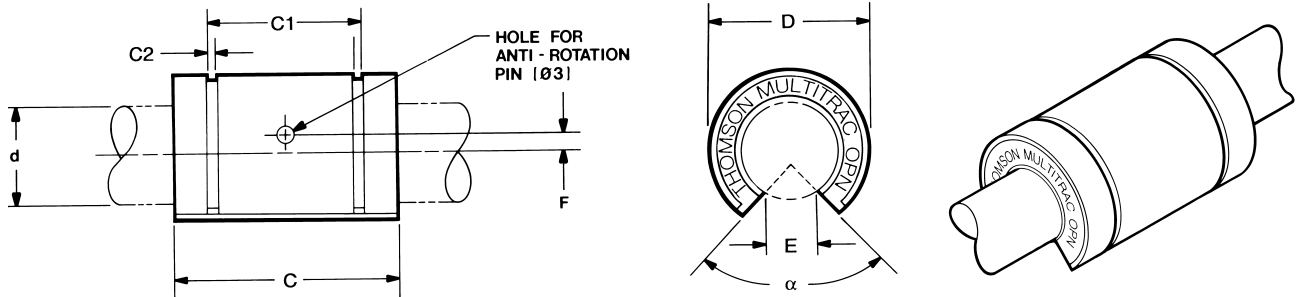

## MultiTrac Ball Bushing Linear Bearings (Open Type) (Dimensions in mm)

Part Number			d <sup>(4)</sup>	D	C h14	C1 H13	C2 min.	E	F	Angle $\alpha$ (deg)	Number of ball tracks	Mass (kg)	Dynamic Load W <sub>0</sub> <sup>(1)(3)</sup> (N)	Load Limit W <sub>0</sub> <sup>(2)(3)</sup> (N)
Without Integral Wipers	With one Integral Wiper	With two Integral Wipers												
MAM120PN	MAM120PNW	MAM120PNWW	12	22	32	22.6	1.30	7.3	1.35	120	4	0.04	440	1100
MAM160PN	MAM160PNW	MAM160PNWW	16	26	36	24.6	1.30	10.6	0	90	6	0.06	600	1500
MAM200PN	MAM200PNW	MAM200PNWW	20	32	45	31.2	1.60	11.5	0	90	6	0.11	1100	2720
MAM250PN	MAM250PNW	MAM250PNWW	25	40	58	43.7	1.85	13.9	1.50 <sup>(6)</sup>	90	6	0.20	2170	5300
MAM300PN	MAM300PNW	MAM300PNWW	30	47	68	51.7	1.85	20.3	2.00	90	6	0.33	2260	6710
MAM400PN	MAM400PNW	MAM400PNWW	40	62	80	60.3	2.15	20.9	1.50	90	6	0.63	4200	10700

(6) Hole for anti-rotation pin is below centerline.

For footnotes 1-5, see pages 156-157.

NOTE: For part number description and specifications, see page 155.

NOTE: External seals and retaining rings are available. See page 173 for specifications.

NOTE: For additional technical information, see the Engineering section beginning on page 256.

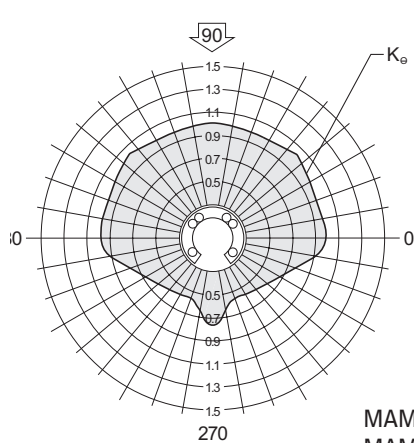

MAM160PN  
MAM200PN  
MAM250PN  
MAM300PN  
MAM400PN

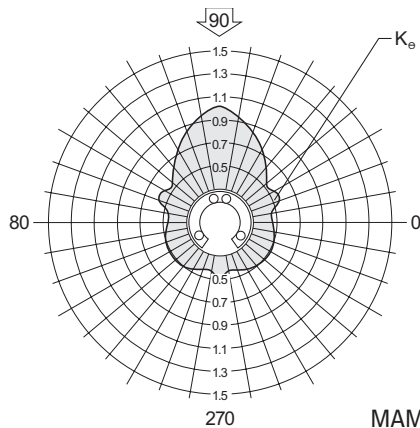

MAM120PN

# MultiTrac Ball Bushing Bearings

Thomson MultiTrac Ball Bushing Bearings are designed with greater rigidity and up to twice the load capacity of conventional linear bearings. The design incorporates a one-piece, bearing-quality, steel sleeve (see Figure 1) for maximum rigidity. The single-piece, engineered-polymer ball retainer provides smooth, quiet operation.

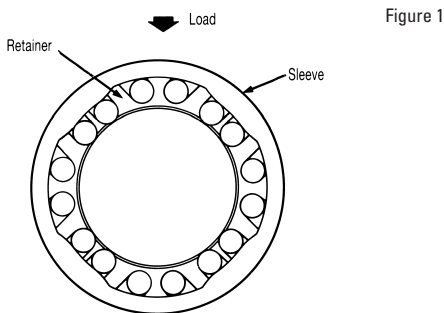

Figure 1

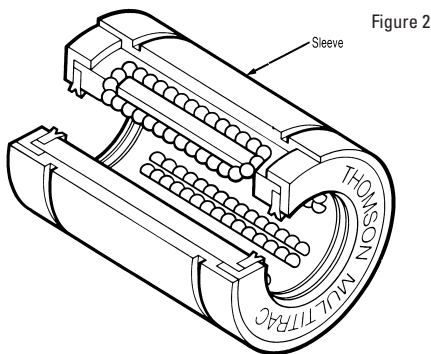

Figure 2

## Twice the Load Capacity

The bearing's load capacity is improved by the optimal positioning of the load tracks. This places the maximum number of load-bearing balls in the load zone (see Figure 1).

## High Speed Operation

The advanced design also improves the bearing's ball control. This allows accelerations as high as 150 m/s<sup>2</sup> and travel speeds up to 3 m/s.

## Integral Seals

The bearing includes double-acting integral wipers, which keep out dirt, grit and other contaminants, and retain bearing lubrication.

## Improved Ball Control

Through advanced, computer-aided design techniques, ball control improvements assure smooth entry and exit of the balls in and out of the load zone.

## Ideal for Corrosive Environments

Optional stainless steel (440C) resists rust and corrosion.



## Application

### Wire Straightening/Feeding Machine

#### Objective

Redesign a wire straightening/feeding mechanism for a wire drawing machine that improves cycle time and minimizes downtime.

#### Solution

Combine the performance advantages of the MultiTrac® Ball Bushing® Linear Bearings with the operating efficiency of Thomson ball screws.

#### Products Specified

- 4 - MAM16WW (MultiTrac Ball Bushing linear bearings)
- 2 - 16 MM CTL x 600 MM (60 Case® LinearRace® shaft)
- 1 - 16 x 5 Thomson ball screw assembly

#### Benefits

Because MultiTrac Ball Bushing Linear Bearings have twice the load capacity of conventional linear bearings, service life increased from six months to four years. This significantly reduced downtime and maintenance requirements and provided increased productivity with substantial cost savings.

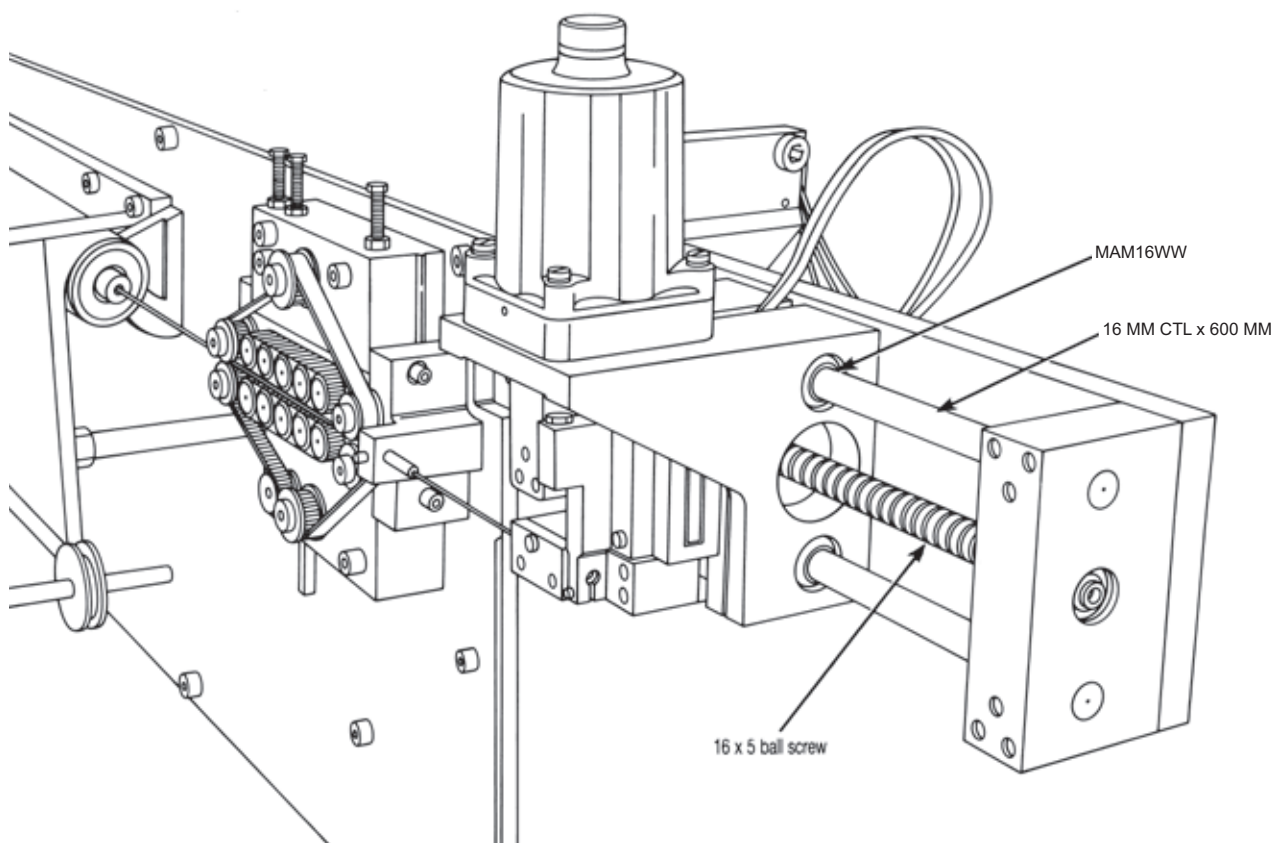

# Application

## Pick and Place X-Y System

### Objective

Build an X-Y System that transfers the work piece between two separate machining stations.

### Solution

Assemble the X-Y System utilizing Super Smart Ball Bushings Bearing pillow blocks on end-supported shafts for the X-axis and continuous supported 60 Case LinearRace shaft on the Y-axis. Utilize Thomson ball screws for high-speed positioning.

### Products Specified

X-axis

2 - 40 MM CTL x 1200 MM (60 Case LinearRace)

4 - SBM40 (shaft support blocks)

4 - SSEPBAM40DD (Super Smart pillow blocks)

1 - 32 x 5 Thomson ball screw assembly Y-axis

2 - LSRAM40 CTL x 1200 MM (Smart Rail guides)

4 - SSEPBOAM40DD (Super Smart pillow blocks)

1 - 32 x 5 Thomson ball screw assembly

### Benefits

The 60 Case LinearRace shafts and shaft support end blocks provided an important bridge between machining stations. The Super Smart pillow blocks and Thomson ball screws provided uninterrupted high speed movement of the work piece. Productivity increased by 200%

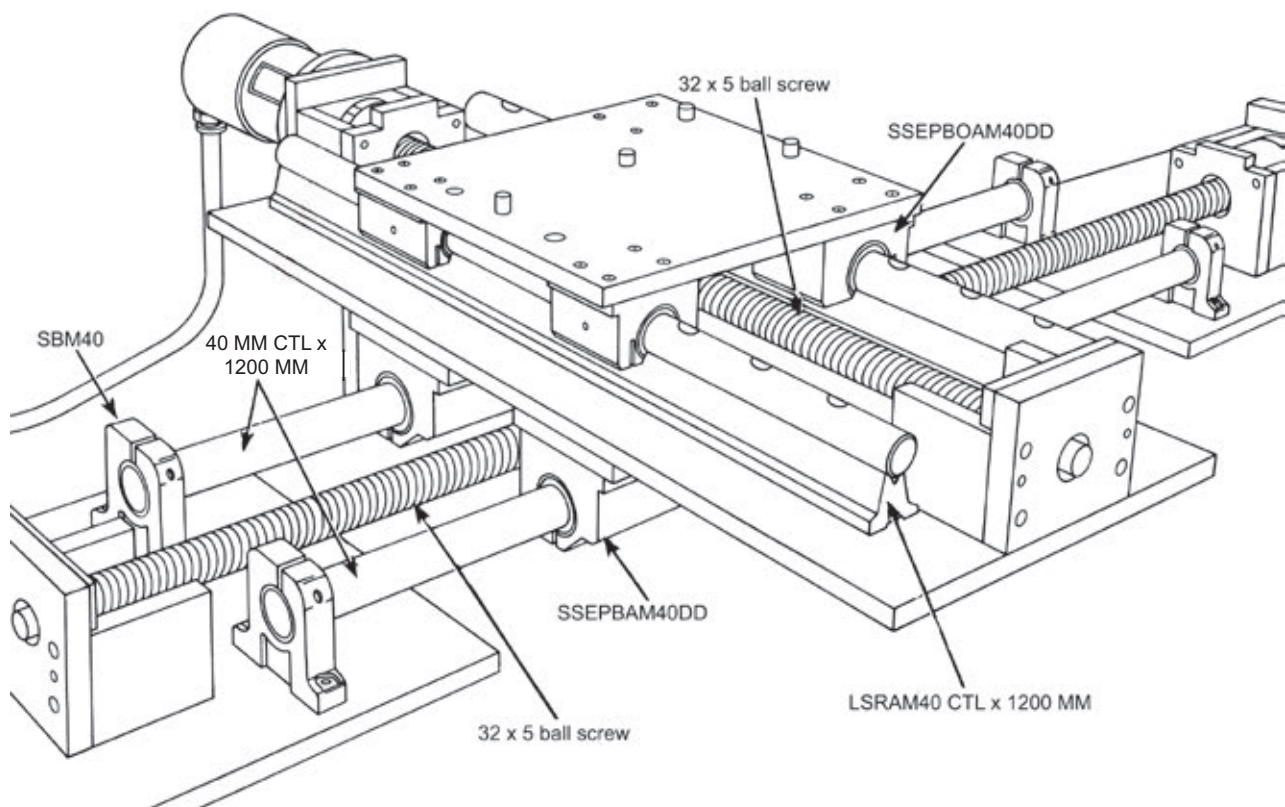



## Super Ball Bushing® Bearings



### High performance from superior design:

- A coefficient of friction as low as 0.001. This allows the use of smaller, less expensive motors, belts, gears and ball screws when replacing high-friction, plain bearings.
- A self-aligning capability up to 0.5° compensates for inaccuracies in base flatness or carriage machining. Achieved with Thomson Super Bearing plates, which have defined radius crowns for maximized self-alignment accuracy.
- Accelerations as high as 150 m/s<sup>2</sup> and steady state travel speeds up to 3 m/s without the derating factors commonly required with linear guides.
- Double-lip, integral wipers that keep out dirt while retaining lubrication. Travel life is maximized.
- Lightweight, wear-resistant, engineered polymer retainers and outer sleeves that reduce inertia and noise.
- Adjustable, closed and open configurations.

### Quick-to-ship, drop-in replacement parts for existing applications:

- Dimensional interchangeable with competitive and legacy applications.
- Easy to order with local manufacturer's stock available in Europe and North America.

### Genuine Thomson Quality:

- Thomson Ball Bushing Bearings in combination with 60 Case® shafting last longer and carry significantly more load than conventional linear bearings, allowing you to reduce component size, saving space and cost. Thomson is the one and only name you'll need when choosing a round rail solution.
- To complete your application with genuine Thomson 60 Case shafting and shaft supports, please visit [www.thomsonlinear.com](http://www.thomsonlinear.com)
- Thomson is the innovator of linear bearings and has supplied superior quality product to the linear industry for more than 75 years. Superior Thomson quality translates to better reliability and performance.

# Part Number Description and Specification

## Super Ball Bushing Bearings

### SPM160PNWW-CR

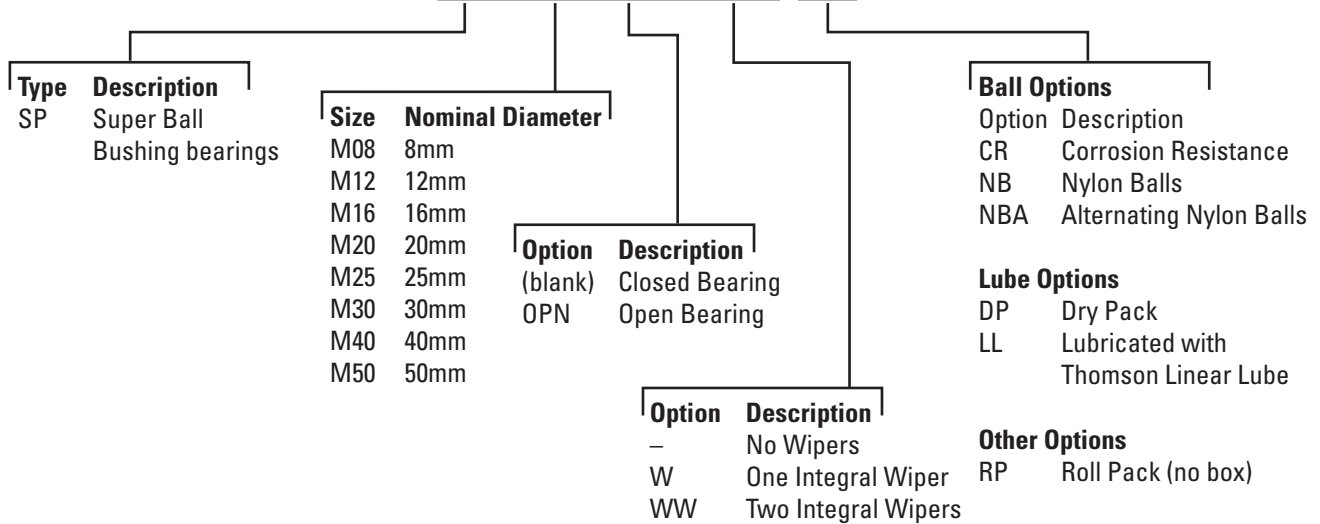

## Super Ball Bushing Pillow Blocks

### SPPBAM16-CR

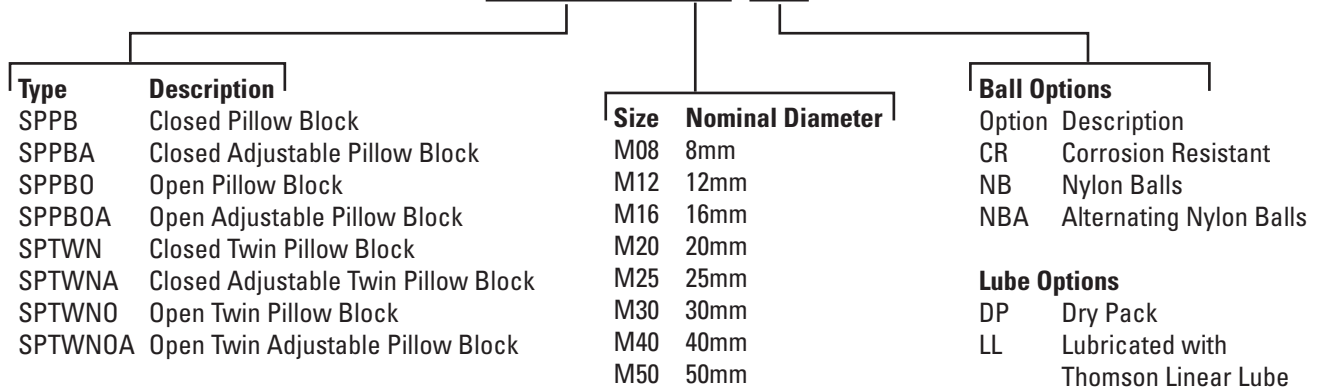

Not all options are available in all sizes.  
 See catalog pages or contact Thomson Customer Support for combination availability.  
 For additional information on bearing options, see page 267.



# Super Ball Bushing® Bearings (Closed Type) for End-Supported Applications

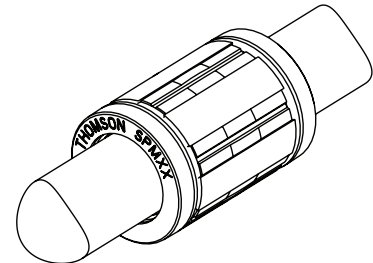
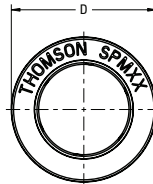
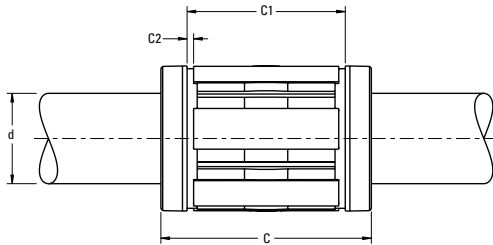

## Super Metric Ball Bushing Bearings (Closed Type)

Part Number			Dimensions (mm)					Number of ball tracks	Mass (kg)	Dynamic Load $W^{(1)}$ (N)	Load Limit $W_0^{(2)}$ (N)
Without Integral Wipers	With One Integral Wiper	With Two Integral Wipers	$\phi d^{(4)}$	$\phi D$	C h14	C1 h13	C2 min				
SPM08	SPM08W	SPM08WW	8	16	25	16.2	1.10	4	0.02	310	340
SPM12	SPM12W	SPM12WW	12	22	32	22.6	1.30	5	0.02	830	910
SPM16	SPM16W	SPM16WW	16	26	36	24.6	1.30	5	0.03	1020	1120
SPM20	SPM20W	SPM20WW	20	32	45	31.2	1.60	6	0.06	2020	2220
SPM25	SPM25W	SPM25WW	25	40	58	43.7	1.85	6	0.13	3950	4350
SPM30	SPM30W	SPM30WW	30	47	68	51.7	1.85	6	0.19	4800	5280
SPM40	SPM40W	SPM40WW	40	62	80	60.3	2.15	6	0.36	8240	9060
SPM50	SPM50W	SPM50WW	50	75	100	77.3	2.65	6	0.66	12060	13270

- (1) For rated travel life of 100 km. For longer travel lives, reduce load to  $W \cdot (100/L)^{0.33}$  where L (km) is the required travel life. Do not exceed the Dynamic Load Rating for travel life of less than 100 km.
- (2) The Load Limit is the maximum load that may be applied to a bearing and shaft. It is important to analyze the application so that peak and/or shock loads do not exceed the Load Limit.
- (3) The load capacities  $W$  and  $W_0$  are valid for a resultant load applied at  $90^\circ$  with the ball tracks oriented as shown in the polar graphs below. If the resultant acts along another direction, the appropriate multiplicative correction factor  $K_\theta$  should be applied to  $W$  and  $W_0$  respectively.
- (4) Internal bearing diameter is affected by the housing bore, see Table 1.
- NOTE: For part number description and specifications, see page 163.
- NOTE: External seals and retaining rings are available. See page 173 for specifications.
- NOTE: For additional technical information, see the Engineering section beginning on page 256.

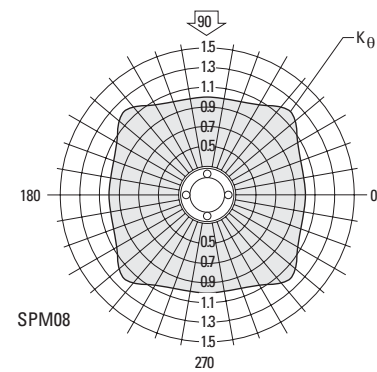
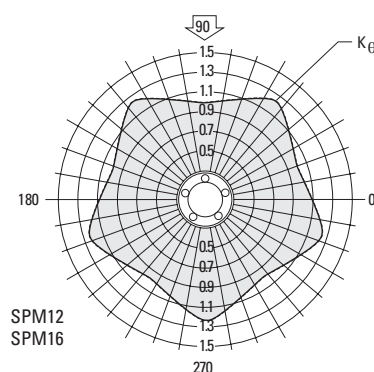
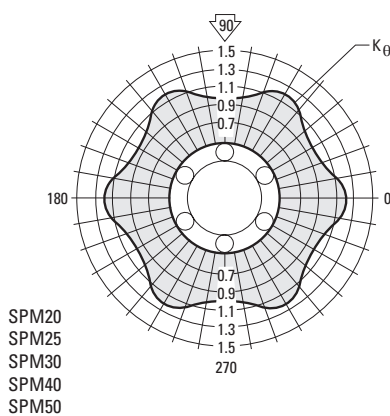

# Super Ball Bushing Bearings (Open Type) for Continuously Supported Applications

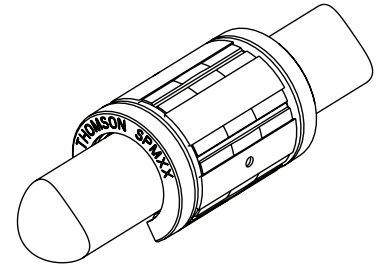
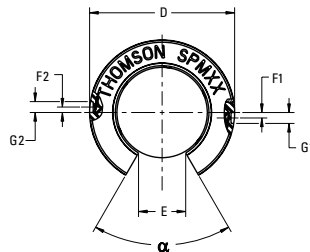
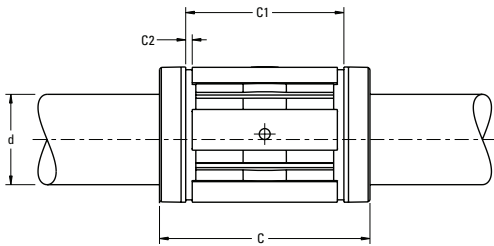

## Super Metric Ball Bushing Bearings (Open Type)

Part Number			Dimensions (mm)											Angle $\alpha$ (deg)	Number of ball tracks	Mass (kg)	Dynamic Load $W^{(1)(3)}$ (N)	Load Limit $W_0^{(2)(3)}$ (N)
Without Integral Wipers	With One Integral Wiper	With Two Integral Wipers	$\phi d^{(4)}$	$\phi D$	C h14	C1 h13	C2 min	E +/- 0.1	F1	$\phi G1$	F2	$\phi G2$						
SPM120PN	SPM120PNW	SPM120PNWW	12	22	32	22.3	1.30	7.0	1.35 (5)	3.1	-	-	70	4	0.02	1060	1170	
SPM160PN	SPM160PNW	SPM160PNWW	16	26	36	24.6	1.30	9.8	0	2.7	-	-	70	4	0.02	1280	1410	
SPM200PN	SPM200PNW	SPM200PNWW	20	32	45	31.2	1.60	10.5	0	3.1	-	-	58	5	0.05	2100	2310	
SPM250PN	SPM250PNW	SPM250PNWW	25	40	58	43.7	1.85	13.0	1.60	3.15	0	3.7	60	5	0.10	4130	4540	
SPM300PN	SPM300PNW	SPM300PNWW	30	47	68	51.7	1.85	15.3	1.90	3.8	2.0	3.3	60	5	0.15	5020	5520	
SPM400PN	SPM400PNW	SPM400PNWW	40	62	80	60.3	2.15	21.4	0	3.6	1.5	3.1	58	5	0.30	8620	9480	
SPM500PN	SPM500PNW	SPM500PNWW	50	75	100	77.3	2.65	24.0	0	4.6	2.5	5.1	55	5	0.55	12500	13750	

- (1) For rated travel life of 100 km. For longer travel lives, reduce load to  $W \cdot (100/L)^{0.33}$  where L (km) is the required travel life. Do not exceed the Dynamic Load Rating for travel life of less than 100 km.
  - (2) The Load Limit is the maximum load that may be applied to a bearing and shaft. It is important to analyze the application so that peak and/or shock loads do not exceed the Load Limit.
  - (3) The load capacities  $W$  and  $W_0$  are valid for a resultant load applied at  $90^\circ$  with the ball tracks oriented as shown in the polar graphs below. If the resultant acts along another direction, the appropriate multiplicative correction factor  $K_\theta$  should be applied to  $W$  and  $W_0$  respectively. Open type bearings have reduced load capacities when used in pull-off situations.
  - (4) Internal bearing diameter is affected by the housing bore, see Table 1.
  - (5) Hole for anti-rotation pin is above centerline.
- NOTE: For part number description and specifications, see page 163.  
 NOTE: External seals and retaining rings are available. See page 173 for specifications.  
 NOTE: For additional technical information, see the Engineering section beginning on page 256.

**Table 1 - Standard Diametral Clearances**

Nominal Shaft Diameter $d$ (mm)	Nominal Housing Bore Diameter $D$ (mm)	Diametral Clearance	
		Housing Bore H7 ( $\mu m$ )	Housing Bore H6 ( $\mu m$ )
12	22	+33 +4	+26 +3
16	26	+33 +4	+26 +3
20	32	+37 +6	+30 +4
25	40	+37 +6	+30 +4
30	47	+37 +6	+30 +4
40	62	+44 +7	+35 +5
50	75	+44 +7	+35 +5

For Super Metric Ball Bushing Bearings mounted in a housing and with LinearRace® shafts, h6 tolerance

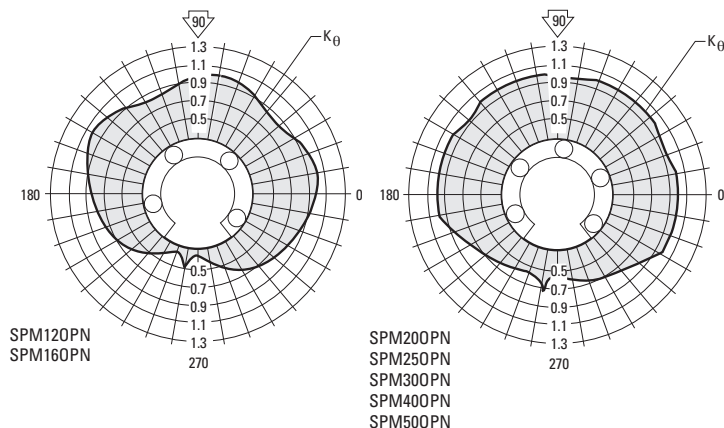



## Super Pillow Blocks



### **Thomson pillow blocks with factory-installed Super Metric Ball Bushing® Bearings offer:**

- Accelerations as high as 150 m/s<sup>2</sup> and steady state travel speeds up to 3 m/s without the derating factors commonly required with linear guides.
- Replaceable bearing components for quick, cost-effective machine maintenance and minimal downtime.
- Lightweight, wear-resistant, engineered polymer retainers and outer sleeves that reduce inertia and noise.
- Standard, double-acting, integral seals at both ends, which keep out dirt, grit and other contaminants, retain lubrication, and maximize bearing life.
- Lubrication hole for easy maintenance.
- Tapped or thru hole mounting configuration for ease of installation.
- Twin version with two Super Ball Bushing Bearings, providing twice the load capacity or eight times more travel life than the single version.
- A single bearing version that self aligns in all directions, minimizing installation time and cost.

Note: See page 162 for information on Thomson Super Metric Ball Bushing Bearings.

# Super Pillow Blocks (Closed Type) for End-Supported Applications

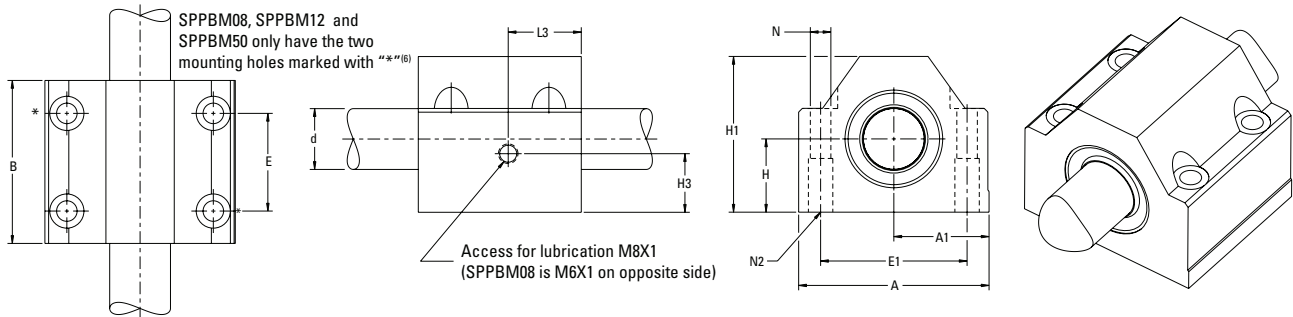

## Super Pillow Blocks (Closed Type)

Part Number	Dimensions (mm)												Mass (kg)	Dynamic Load $W^{(1)(3)}$ (N)	Load Limit $W_0^{(2)(3)}$ (N)
	$\phi d^{(4)}$	H +/- 0.020	H1	A	A1 +/- 0.020	B	E +/- 0.1	E1 +/- 0.1	H3	L3 <sup>(5)</sup>	$\phi N$	N2			
SPPBM08	8	15	28	35	17.5	32	20 <sup>(6)</sup>	25 <sup>(6)</sup>	12 <sup>(5)</sup>	8.5	3.3	M4	0.07	310	340
SPPBM12	12	18	35	43	21.5	39	23 <sup>(6)</sup>	32 <sup>(6)</sup>	10	10.5	4.3	M5	0.13	830	910
SPPBM16	16	22	42	53	26.5	43	26	40	12	16.5	5.3	M6	0.21	1020	1120
SPPBM20	20	25	50	60	30.0	54	32	45	13	20.5	6.6	M8	0.35	2020	2220
SPPBM25	25	30	60	78	39.0	67	40	60	15	23	8.4	M10	0.66	3950	4350
SPPBM30	30	35	71	87	43.5	79	45	68	20	27	8.4	M10	0.97	4800	5280
SPPBM40	40	45	91	108	54.0	91	58	86	21.5	30	10.5	M12	1.81	8240	9060
SPPBM50	50	50	105	132	66.0	113	50 <sup>(6)</sup>	108 <sup>(6)</sup>	12.5	22	13.5	M16	3.00	12060	13270

- (1) For rated travel life of 100 km. For longer travel lives, reduce load to  $W \cdot (100/L)^{0.33}$  where L (km) is the required travel life. Do not exceed the Dynamic Load Rating for travel life of less than 100 km.
  - (2) The Load Limit is the maximum load that may be applied to a bearing and shaft. It is important to analyze the application so that peak and/or shock loads do not exceed the Load Limit.
  - (3) The load capacities W and  $W_0$  are valid for a resultant load applied at 90° with the ball tracks oriented as shown in the polar graphs below. If the resultant acts along another direction, the appropriate multiplicative correction factor  $K_\theta$  should be applied to W and  $W_0$  respectively.
  - (4) For bearing diametral clearances, see Table 2.
  - (5) SPPBM08 lube hole is M6X1 tapped hole located on opposite side
  - (6) SPPBM08, SPPBM12 and SPPBM50 pillow blocks have only two mounting holes. The mounting holes on these sizes are marked in the drawing above with "\*" NOTE: For part number description and specifications, see page 163.
- NOTE: External seals and retaining rings are available. See page 173 for specifications.  
NOTE: For additional technical information, see the Engineering section beginning on page 256.

**Table 2 - Standard Diametral Clearances (Closed Type)**

Nominal Size d (mm)	Diametral Clearance (µm)
8	+23 +2
12	+26 +3
16	+26 +3
20	+30 +4
25	+30 +4
30	+30 +4
40	+35 +5
50	+35 +5

For Pillow Blocks used with LinearRace Shaft, h6 tolerance

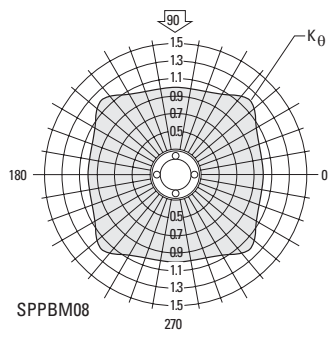
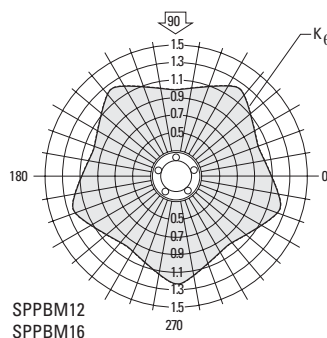
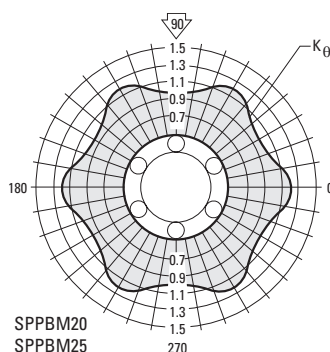



# Super Pillow Blocks (Closed Adjustable Type) for End-Supported Applications

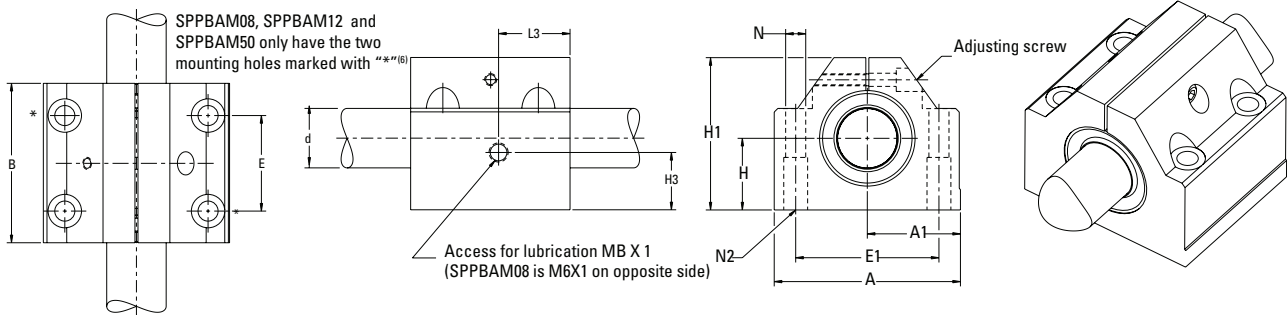

## Super Pillow Blocks (Closed Adjustable Type)

Part Number	Dimensions (mm)												Mass (kg)	Dynamic Load $W^{(1)(3)}$ (N)	Load Limit $W_0^{(2)(3)}$ (N)
	$\varnothing$	H +/- 0.020	H1	A	A1 +/- 0.020	B	E +/- 0.1	E1 +/- 0.1	H3	L3	$\varnothing N$	N2			
SPPBAM08	8	15	28	35	17.5	32	20 <sup>(6)</sup>	25 <sup>(6)</sup>	12 <sup>(5)</sup>	8,5 <sup>(5)</sup>	3.3	M4	0.07	310	340
SPPBAM12	12	18	35	43	21.5	39	23 <sup>(6)</sup>	32 <sup>(6)</sup>	10	10.5	4.3	M5	0.13	830	910
SPPBAM16	16	22	42	53	26.5	43	26	40	16	15.7	5.3	M6	0.21	1020	1120
SPPBAM20	20	25	50	60	30.0	54	32	45	13	20	6.6	M8	0.35	2020	2220
SPPBAM25	25	30	60	78	39.0	67	40	60	15	23	8.4	M10	0.66	3950	4350
SPPBAM30	30	35	71	87	43.5	79	45	68	16	26.5	8.4	M10	0.97	4800	5280
SPPBAM40	40	45	91	108	54.0	91	58	86	21.5	30	10.5	M12	1.81	8240	9060
SPPBAM50	50	50	105	132	66.0	113	50 <sup>(6)</sup>	108 <sup>(6)</sup>	12.5	22	13.5	M16	3.00	12060	13270

- (1) For rated travel life of 100 km. For longer travel lives, reduce load to  $W \cdot (100/L)^{0.33}$  where L (km) is the required travel life. Do not exceed the Dynamic Load Rating for travel life of less than 100 km.
- (2) The Load Limit is the maximum load that may be applied to a bearing and shaft. It is important to analyze the application so that peak and/or shock loads do not exceed the Load Limit.
- (3) The load capacities  $W$  and  $W_0$  are valid for a resultant load applied at 90° with the ball tracks oriented as shown in the polar graphs below. If the resultant acts along another direction, the appropriate multiplicative correction factor  $K_\theta$  should be applied to  $W$  and  $W_0$  respectively.
- (4) For bearing diametral clearances, see Table 2.
- (5) SPPBAM08 lube hole is M6X1 tapped hole located on opposite side
- (6) SPPBAM08, SPPBAM12 and SPPBAM50 pillow blocks have only two mounting holes. The mounting holes on these sizes are marked in the drawing above with "\*" NOTE: For part number description and specifications, see page 163.
- NOTE: External seals and retaining rings are available. See page 173 for specifications.
- NOTE: For additional technical information, see the Engineering section beginning on page 256.

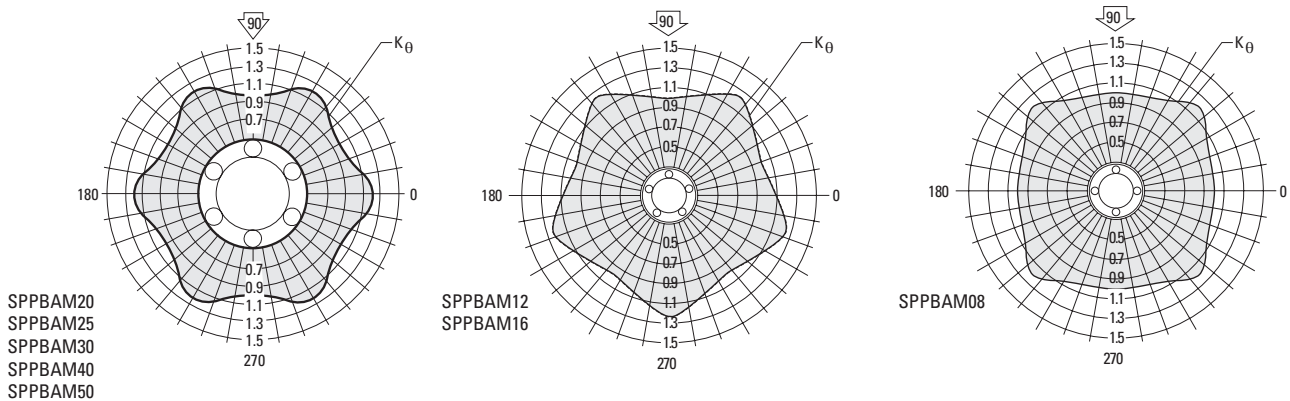

# Super Pillow Blocks (Open Type) for Continuously Supported Applications

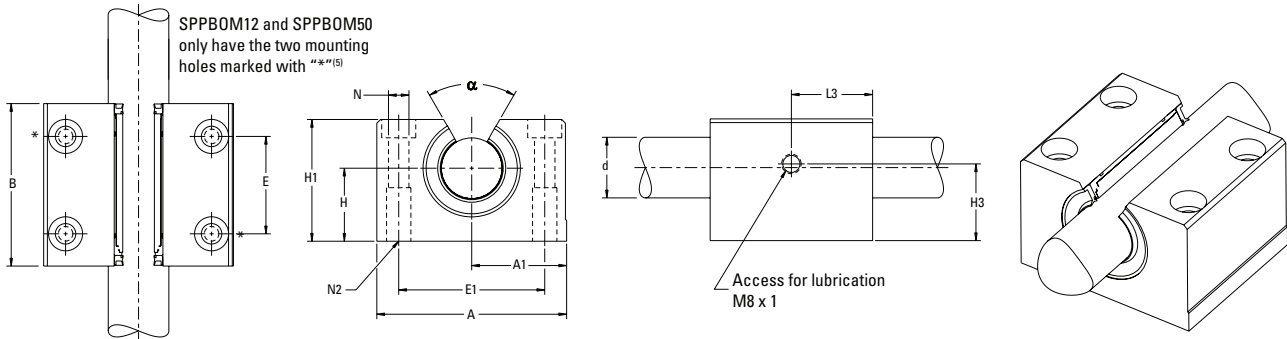

## Super Pillow Blocks (Open Type)

Part Number	Dimensions (mm)												Angle $\alpha$ (deg)	Mass (kg)	Dynamic Load $W^{(1)(3)}$ (N)	Load Limit $W_0^{(2)(3)}$ (N)
	$\varnothing d^{(4)}$	H +/- 0.020	H1	A	A1 +/- 0.020	B	E +/- 0.1	E1 +/- 0.1	H3	L3	$\varnothing N$	N2				
SPPBOM12	12	18	28	43	21.5	39	23 <sup>(6)</sup>	32 <sup>(6)</sup>	10	10.5	4.3	M5	70	0.11	1060	1170
SPPBOM16	16	22	35	53	26.5	43	26	40	10.8	15.7	5.3	M6	58	0.19	1280	1410
SPPBOM20	20	25	41	60	30.0	54	32	45	13	20	6.6	M8	60	0.30	2100	2310
SPPBOM25	25	30	50	78	39.0	67	40	60	15	23	8.4	M10	60	0.60	4130	4540
SPPBOM30	30	35	60	87	43.5	79	45	68	20.5	27	8.4	M10	58	0.92	5020	5520
SPPBOM40	40	45	77	108	54.0	91	58	86	21.5	30	10.5	M12	55	1.65	8620	9480
SPPBOM50	50	50	88	132	66.0	113	50 <sup>(6)</sup>	108 <sup>(6)</sup>	12.5	22	13.5	M16	55	2.60	12500	13750

- (1) For rated travel life of 100 km. For longer travel lives, reduce load to  $W \cdot (100/L)^{0.33}$  where L (km) is the required travel life. Do not exceed the Dynamic Load Rating for travel life of less than 100 km.
  - (2) The Load Limit is the maximum load that may be applied to a bearing and shaft. It is important to analyze the application so that peak and/or shock loads do not exceed the Load Limit.
  - (3) The load capacities W and  $W_0$  are valid for a resultant load applied at 90° with the ball tracks oriented as shown in the polar graphs below. If the resultant acts along another direction, the appropriate multiplicative correction factor  $K_\theta$  should be applied to W and  $W_0$  respectively. Open type bearings have reduced load capacities when used in pull-off situations.
  - (4) For bearing diametral clearances, see Table 3.
  - (5) SPPBOM12 and SPPBOM50 pillow blocks have only two mounting holes. The mounting holes on these sizes are marked in the drawing above with "\*"\*
- NOTE: For part number description and specifications, see page 163.  
 NOTE: External seals and retaining rings are available. See page 173 for specifications.  
 NOTE: For additional technical information, see the Engineering section beginning on page 256.

**Table 3 - Standard Diametral Clearances (Open Type)**

Nominal Size d (mm)	Diametral Clearance ( $\mu\text{m}$ )
12	+26 +3
16	+26 +3
20	+30 +4
25	+30 +4
30	+30 +4
40	+35 +5
50	+35 +5

For Pillow Blocks used with Linear-Race Shaft, h6 tolerance

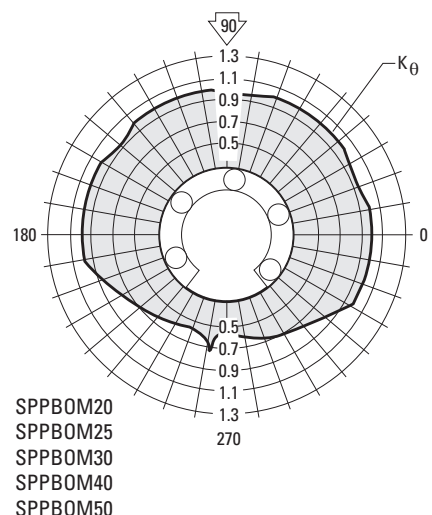
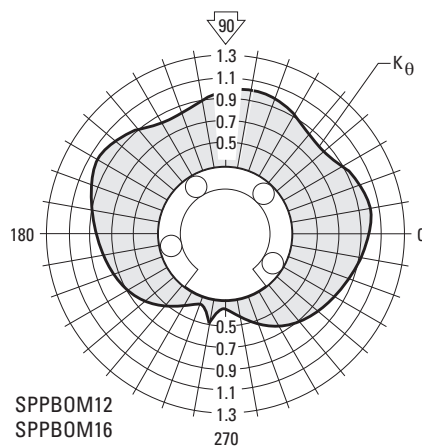



# Super Pillow Blocks (Open Adjustable Type) for Continuously Supported Applications

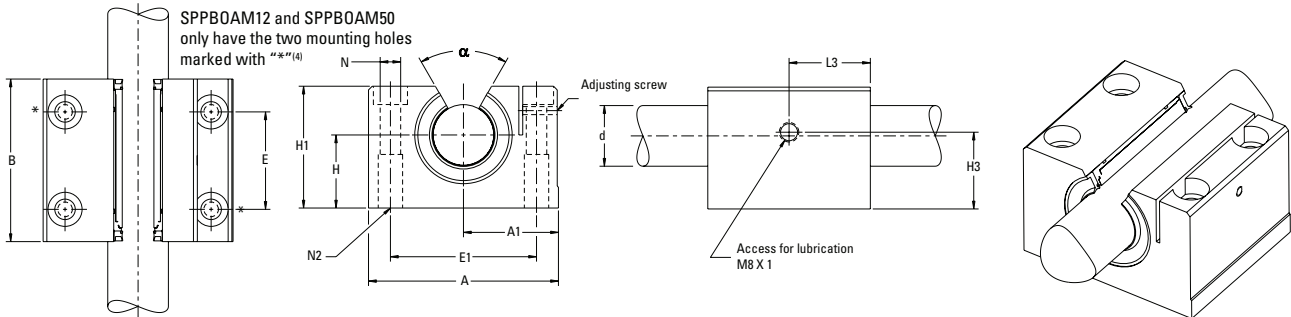

## Super Pillow Blocks (Open Adjustable Type)

Part Number	Dimensions (mm)												Angle $\alpha$ (deg)	Mass (kg)	Dynamic Load $W^{(1)(3)}$ (N)	Load Limit $W_0^{(2)(3)}$ (N)
	$\varnothing d$	H +/- 0.020	H1	A	A1 +/- 0.020	B	E +/-0.1	E1 +/-0.1	H3	L3	$\varnothing N$	N2				
SPPBOAM12	12	18	28	43	21.5	39	23 <sup>(4)</sup>	32 <sup>(4)</sup>	10	10.5	4.3	M5	70	0.11	1060	1170
SPPBOAM16	16	22	35	53	26.5	43	26	40	10.8	15.7	5.3	M6	58	0.19	1280	1410
SPPBOAM20	20	25	41	60	30.0	54	32	45	13	20	6.6	M8	60	0.30	2100	2310
SPPBOAM25	25	30	50	78	39.0	67	40	60	15	23	8.4	M10	60	0.60	4130	4540
SPPBOAM30	30	35	60	87	43.5	79	45	68	20.5	27	8.4	M10	58	0.92	5020	5520
SPPBOAM40	40	45	77	108	54.0	91	58	86	21.5	30	10.5	M12	55	1.65	8620	9480
SPPBOAM50	50	50	88	132	66.0	113	50 <sup>(4)</sup>	108 <sup>(4)</sup>	12.5	22	13.5	M16	55	2.60	12500	13750

- (1) For rated travel life of 100 km. For longer travel lives, reduce load to  $W \cdot (100/L)^{0.33}$  where L (km) is the required travel life. Do not exceed the Dynamic Load Rating for travel life of less than 100 km.
  - (2) The Load Limit is the maximum load that may be applied to a bearing and shaft. It is important to analyze the application so that peak and/or shock loads do not exceed the Load Limit.
  - (3) The load capacities  $W$  and  $W_0$  are valid for a resultant load applied at  $90^\circ$  with the ball tracks oriented as shown in the polar graphs below. If the resultant acts along another direction, the appropriate multiplicative correction factor  $K_\theta$  should be applied to  $W$  and  $W_0$  respectively. Open type bearings have reduced load capacities when used in pull-off situations.
  - (4) SPPBOAM12 and SPPBOAM50 pillow blocks have only two mounting holes. The mounting holes on these sizes are marked in the drawing above with "\*\*"
- NOTE: For part number description and specifications, see page 163.  
NOTE: External seals and retaining rings are available. See page 173 for specifications.  
NOTE: For additional technical information, see the Engineering section beginning on page 256.

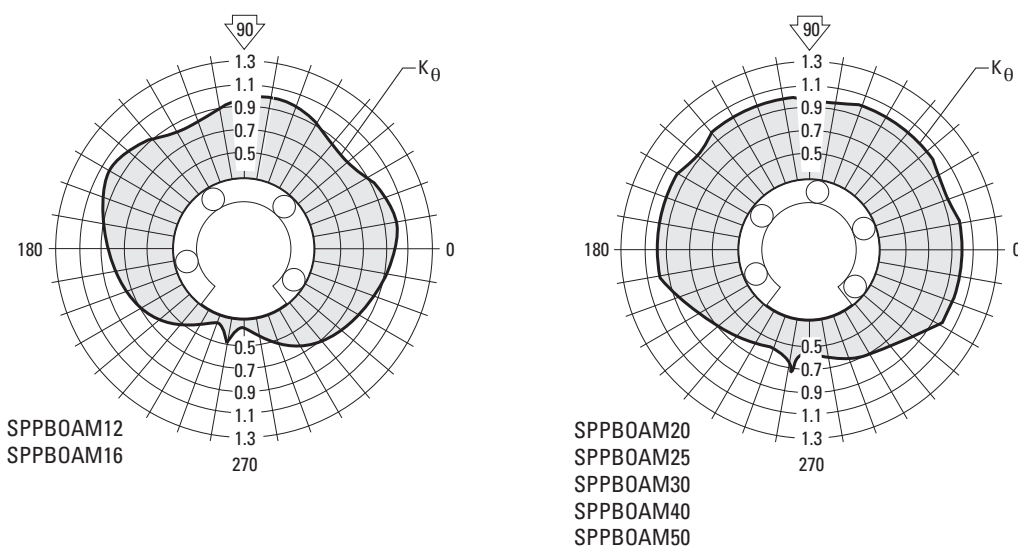

## Super Twin Pillow Blocks (Closed Type) for End Supported Applications

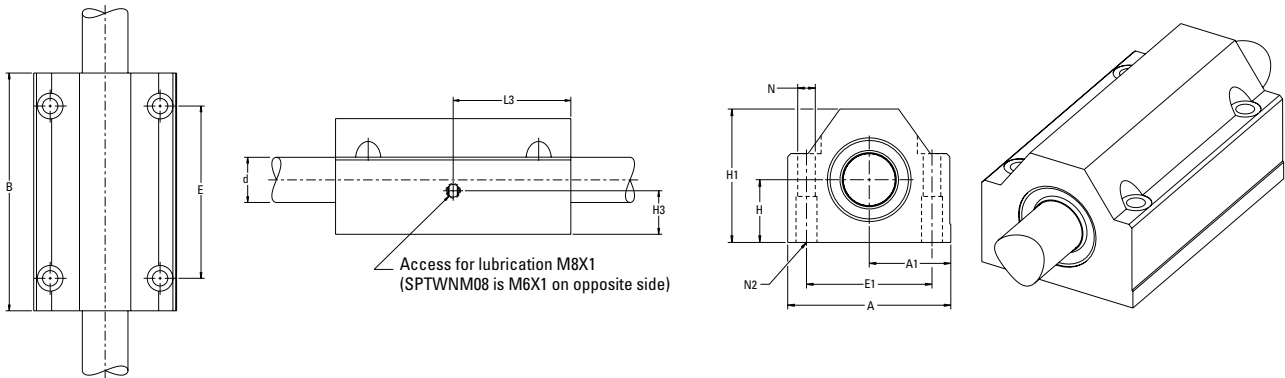

Part Number	Dimensions (mm)												Mass (kg)	Dynamic Load $W^{(1)(3)}$ (N)	Load Limit $W_0^{(2)(3)}$ (N)
	$\varnothing d^{(4)}$	H +/- 0.020	H1	A	A1 +/- 0.020	B	E +/- 0.1	E1 +/- 0.1	H3	L3	$\varnothing N$	N2			
SPTWNM08	8	15	28	35	17.5	62	50	25	12 <sup>(5)</sup>	31 <sup>(5)</sup>	3.3	M4	0.15	500	550
SPTWNM12	12	18	35	43	21.5	76	56	32	10	38	4.3	M5	0.27	1350	1490
SPTWNM16	16	22	42	53	26.5	84	64	40	16	42	5.3	M6	0.41	1660	1830
SPTWNM20	20	25	50	60	30.0	104	76	45	13	52	6.6	M8	0.66	3280	3610
SPTWNM25	25	30	60	78	39.0	130	94	60	15	65	8.4	M10	1.22	6410	7050
SPTWNM30	30	35	71	87	43.5	152	106	68	16	76	8.4	M10	1.90	7800	8580
SPTWNM40	40	45	91	108	54.0	176	124	86	21.5	88	10.5	M12	3.57	13380	14720
SPTWNM50	50	50	105	132	66.0	224	160	108	20	112	13.5	M16	6.30	19590	21550

## (Closed Adjustable Type) for End-Supported Applications

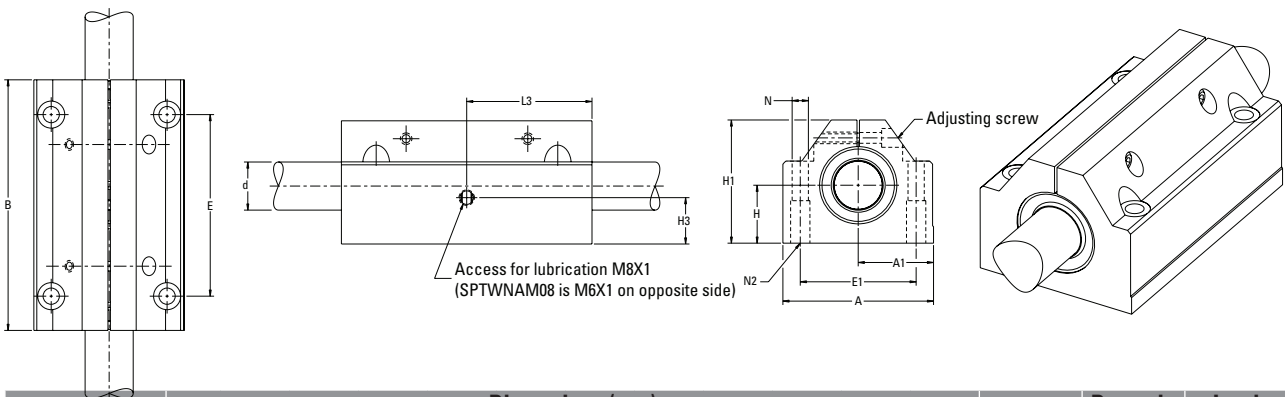

Part Number	Dimensions (mm)												Mass (kg)	Dynamic Load $W^{(1)(3)}$ (N)	Load Limit $W_0^{(2)(3)}$ (N)
	$\varnothing d^{(4)}$	H +/- 0.020	H1	A	A1 +/- 0.020	B	E +/- 0.1	E1 +/- 0.1	H3	L3	$\varnothing N$	N2			
SPTWNA08	8	15	28	35	17.5	62	50	25	12 <sup>(5)</sup>	31 <sup>(5)</sup>	3.3	M4	0.15	500	550
SPTWNA12	12	18	35	43	21.5	76	56	32	10	38	4.3	M5	0.27	1350	1490
SPTWNA16	16	22	42	53	26.5	84	64	40	12	42	5.3	M6	0.41	1660	1830
SPTWNA20	20	25	50	60	30.0	104	76	45	13	52	6.6	M8	0.66	3280	3610
SPTWNA25	25	30	60	78	39.0	130	94	60	15	65	8.4	M10	1.22	6410	7050
SPTWNA30	30	35	71	87	43.5	152	106	68	20	76	8.4	M10	1.90	7800	8580
SPTWNA40	40	45	91	108	54.0	176	124	86	21.5	88	10.5	M12	3.57	13380	14720
SPTWNA50	50	50	105	132	66.0	224	160	108	20	112	13.5	M16	6.30	19590	21550

See footnotes (1) (2) (3) (4) (5) (6) on page 168. For diametral clearances, see single versions of pillow block.

NOTE: For part number description and specifications, see page 163.

NOTE: External seals and retaining rings are available. See page 173 for specifications.

NOTE: For additional technical information, see the Engineering section beginning on page 256.



# Super Twin Pillow Blocks

## (Open Type) for Continuously Supported Applications

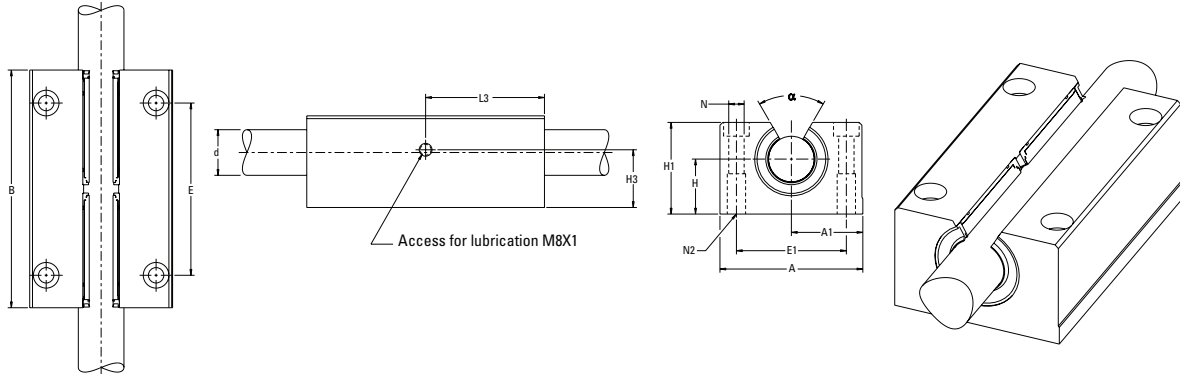

Part Number	Dimensions (mm)												Angle $\alpha$ (deg)	Mass (kg)	Dynamic Load $W^{(1)(3)}$ (N)	Load Limit $W_0^{(2)(3)}$ (N)
	$\varnothing d^{(4)}$	H +/- 0.020	H1	A	A1 +/- 0.020	B	E +/-0.1	E1 +/-0.1	H3	L3	$\varnothing N$	N2				
SPTWNOM12	12	18	28	43	21.5	76	56	32	10	38	4.3	M5	70	0.22	1350	1490
SPTWNOM16	16	22	35	53	26.5	84	64	40	18	42	5.3	M6	58	0.37	1660	1830
SPTWNOM20	20	25	41	60	30.0	104	76	45	16	52	6.6	M8	60	0.57	3280	3610
SPTWNOM25	25	30	50	78	39.0	130	94	60	15	65	8.4	M10	60	1.15	6410	7050
SPTWNOM30	30	35	60	87	43.5	152	106	68	16	76	8.4	M10	58	1.76	7800	8580
SPTWNOM40	40	45	77	108	54.0	176	124	86	21.5	88	10.5	M12	55	3.22	13380	14720
SPTWNOM50	50	50	88	132	66.0	224	160	108	20	112	13.5	M16	55	5.50	19590	21550

## (Open Adjustable Type) for Continuously Supported Applications

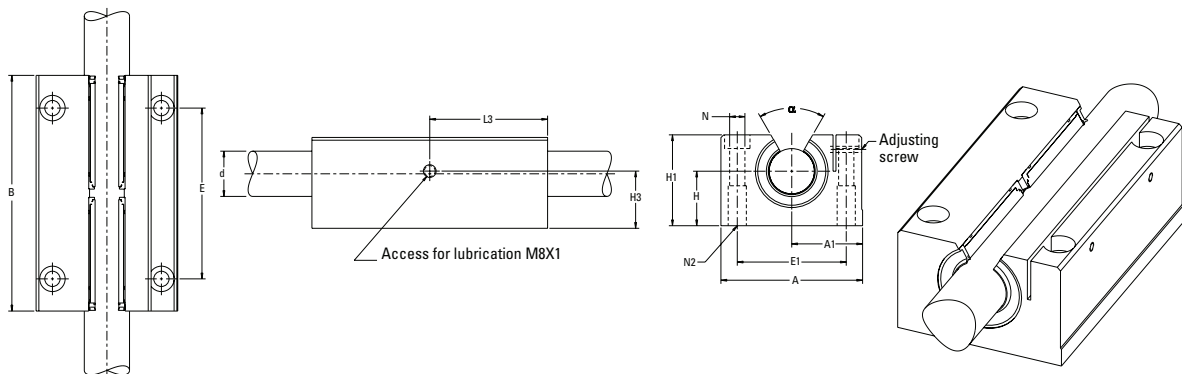

Part Number	Dimensions (mm)												Angle $\alpha$ (deg)	Mass (kg)	Dynamic Load $W^{(1)(3)}$ (N)	Load Limit $W_0^{(2)(3)}$ (N)
	$\varnothing d$	H +/- 0.020	H1	A	A1 +/- 0.020	B	E +/-0.1	E1 +/-0.1	H3	L3	$\varnothing N$	N2				
SPTWNOAM12	12	18	28	43	21.5	76	56	32	10	38	4.3	M5	70	0.22	1350	1490
SPTWNOAM16	16	22	35	53	26.5	84	64	40	18	42	5.3	M6	58	0.37	1660	1830
SPTWNOAM20	20	25	41	60	30.0	104	76	45	16	52	6.6	M8	60	0.57	3280	3610
SPTWNOAM25	25	30	50	78	39.0	130	94	60	15	65	8.4	M10	60	1.15	6410	7050
SPTWNOAM30	30	35	60	87	43.5	152	106	68	16	76	8.4	M10	58	1.76	7800	8580
SPTWNOAM40	40	45	77	108	54.0	176	124	86	21.5	88	10.5	M12	55	3.22	13380	14720
SPTWNOAM50	50	50	88	132	66.0	224	160	108	20	112	13.5	M16	55	5.50	19590	21550

See footnotes (1) (2) (3) (4) on page 170. For diametral clearances, see single versions of pillow block.

NOTE: For part number description and specifications, see page 163.

NOTE: External seals and retaining rings are available. See page 173 for specifications.

NOTE: For additional technical information, see the Engineering section beginning on page 256.

## Accessories



Described here are accessories for Linear Ball Bushing® Bearings and pillow blocks, including retaining rings and external seals.



# Retaining Rings

## Internal Retaining Rings

Push-in internal retaining rings, as shown, are for use with Metric Ball Bushing® Bearings. Each retaining ring is installed inside the housing bore at each end of the bearing.

(Dimensions in mm)

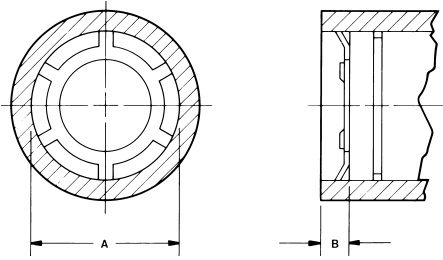

Part Number	Use with Ball Bushing Bearing Number	Nominal Shaft Diameter	Nominal Housing Bore A	Minimum End Space required B
PRM08	SPM08 or MAM08	8	16	1.5
PRM12	SPM12 or MAM12	12	22	2.0
PRM16	SSEM16 or MAM16	16	26	2.0
PRM20	SSEM20 or MAM20	20	32	2.0
PRM25	SSEM25 or MAM25	25	40	2.0
PRM30	SSEM30 or MAM30	30	47	2.0
PRM40	SSEM40 or MAM40	40	62	2.5
PRJ16	SSJM16	16	28	2.0
PRJ20	SSJM20	20	32	2.0
PRJ25	SSJM25	25	40	2.0
PRJ30	SSJM30	30	45	2.0
PRJ40	SSJM40	40	60	2.5

## External Retaining Rings

External retaining rings are used to form one or two shoulders on the O.D. of the Metric Ball Bushing Bearings.

(Dimensions in mm)

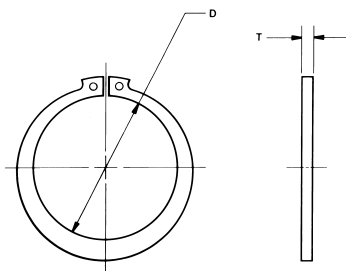

Part Number	Use with Ball Bushing Bearing Number	Nominal Shaft Diameter	T	Free Diameter D
WRM08	SPM08 or MAM08	8	1.00	14.7
WRM12	SPM12 or MAM12	12	1.20	20.5
WRM16	SSEM16 or MAM16	16	1.20	24.2
WRM20	SSEM20 or MAM20	20	1.50	29.6
WRM25	SSEM25 or MAM25	25	1.75	36.5
WRM30	SSEM30 or MAM30	30	1.75	43.5
WRM40	SSEM40 or MAM40	40	2.00	57.8
WRJ16	SSJM16	16	1.50	27.0
WRJ20	SSJM20	20	1.50	30.0
WRJ25	SSJM25	25	1.75	38.0
WRJ30	SSJM30	30	1.75	43.0
WRJ40	SSJM40	40	2.00	57.0

## External Seals

### External Seals for Closed Metric Ball Bushing Bearings

Double-acting seals for use in fixed diameter housings.

(Dimensions in mm)

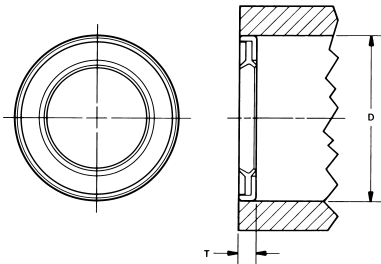

Part Number	Use with Ball Bushing Bearing Number	Nominal Shaft Diameter	T	Nominal Housing Diameter (1) D
SM08	SPM08 or MAM08	8	3.0	16
SM12	SPM12 or MAM12	12	3.0	22
SM16	SSEM16 or MAM16	16	3.0	26
SM20	SSEM20 or MAM20	20	4.0	32
SM25	SSEM25 or MAM25	25	4.0	40
SM30	SSEM30 or MAM30	30	5.0	47
SM40	SSEM40 or MAM40	40	5.0	62

### External Seals for Adjustable Metric Ball Bushing Bearings

Double-acting seals for use in adjustable diameter housings. Series ADJ seals have a radial slot through the circumference to facilitate diameter adjustment.

(Dimensions in mm)

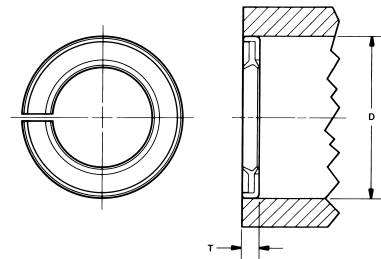

Part Number	Use with Ball Bushing Bearing Number	Nominal Shaft Diameter	T	Nominal Housing Diameter (1) D
SM08ADJ	SPM08 or MAM08	8	3.0	16
SM12ADJ	SPM12 or MAM12	12	3.0	22
SM16ADJ	SSEM16 or MAM16	16	3.0	26
SM20ADJ	SSEM20 or MAM20	20	4.0	32
SM25ADJ	SSEM25 or MAM25	25	4.0	40
SM30ADJ	SSEM30 or MAM30	30	5.0	47
SM40ADJ	SSEM40 or MAM40	40	5.0	62

### External Seals for Open Metric Ball Bushing Bearings

Double-acting seals for use in open type housings.

(Dimensions in mm)

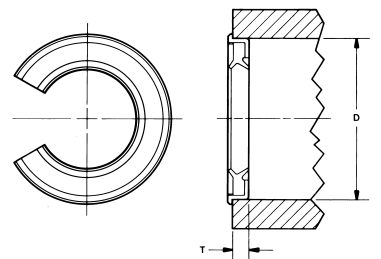

Part Number	Use with Ball Bushing Bearing Number	Nominal Shaft Diameter	T	Free Diameter D
SM120PN	SPM12 or MAM12	12	3.20	22
SM160PN	SSEM16 or MAM16	16	3.20	26
SM200PN	SSEM20 or MAM20	20	4.20	32
SM250PN	SSEM25 or MAM25	25	4.20	40
SM300PN	SSEM30 or MAM30	30	5.15	47
SM400PN	SSEM40 or MAM40	40	5.15	62

(1) For use in tolerance zones up to H7.



## 60 Case® LinearRace® Shafting



<b>60 Case LinearRace Shafting</b> .....	<b>176</b>
60 Case Product Overview.....	177
<b>Inch 60 Case Shafting</b> .....	<b>182</b>
Support Rails and Support Rail Assemblies .....	189
Support Block .....	193
<b>Metric 60 Case Shafting</b> .....	<b>195</b>
Support Rails and Support Rail Assemblies .....	198
Support Block .....	201
<b>Quick Shaft</b> .....	<b>202</b>
<b>Special Machining</b> .....	<b>206</b>

## 60 Case LinearRace Product Overview

For more than 75 years, Thomson has been producing precision linear shafting for the Thomson Linear Ball Bushing® and other applications.

- We are one of a few linear motion component suppliers producing their own shafting.
- We offer the largest selection of linear shafting – not just the popular sizes.
- We offer a complete linear motion solution – not just one component of a linear system.
- We offer the widest range of inch and metric shafting, support rails and support blocks in the market today.
- We continually optimize our processes to ensure optimal bearing performance and extended life.
- We perform thousands of hours of laboratory testing per year to continually evaluate our products.

While shafts may appear the same to the untrained eye on the surface, there are significant performance differences due to the manufacturer's selected standards and the manufacturing processes used to achieve them. Thomson 60 Case was developed and is continually enhanced because of our goal to provide a consistent finish, roundness, straightness, cylindricity case hardness and depth on all shafting for the demands of a linear bearing. Unlike common shafting, Thomson 60 Case shafting is manufactured to the highest quality standards in an ISO 9000:2000 registered facility. Our techniques have been continuously upgraded with proprietary knowledge gained from more than 75 years of manufacturing experience. Using Thomson 60 Case with Thomson Ball Bushing Bearings ensures optimal bearing performance and travel life.

### Assortment

Thomson 60 Case is available from stock in carbon steel, 440C Stainless Steel, 52100 Tubular, 316 Stainless Steel, carbon steel chrome plated, carbon steel predrilled and 440C Stainless Predrilled from 3/16 to 4". Thomson 60 Case can be mounted or delivered pre-assembled in three configurations: type SR standard support rails, type LSR low-profile support rails and type XSR extra-rigid support rails. Contact Thomson or review the catalog datasheets to see available diameters for the different materials. Thomson has the widest range of materials and diameters available on the market from one source.



### Material

Thomson 60 Case carbon steel shafting is made of high-quality, specially developed alloy steel. When it comes to linear shafting, no other manufacturers have set such high standards or specifications for the raw steel used in the production of linear shafting. The chemical properties of the steel are customized to provide consistent, homogenous microstructure and proper response to thermal processing. When you use Thomson 60 Case, you can be confident you get consistent material from shaft to shaft.

### Case Hardness

All Thomson 60 Case is induction hardened, and the hardness varies by material type. Thomson 60 Case carbon steel shaft is induction hardened to a 60 Rc min. The Thomson 440C "corrosion resistant" stainless steel shafting is hardened to a 50 Rc min. The 316 Thomson "corrosion proof" stainless steel is not hardened. The Thomson 52100 Tubular shafting is hardened to a 58 Rc min.

### Case Depth

The case depth on all Thomson 60 Case shafting is precisely controlled for consistent quality and optimal performance. The extremely hard surface minimizes wear when acting as an inner race of a linear bearing, is resistant to seal lip wear, nicks and scratches for your application needs. The Thomson 60 Case standard case depth is, in some cases, double competitor shafting. This deeper standard case depth provides a stronger, more consistent homogenous microstructure for a linear bearing to run on, leading to an increase in shaft life. For special applications, Thomson offers deep case in carbon steel, where the case depth is two times the normal depth. For specific case depths, refer to catalog datasheets.

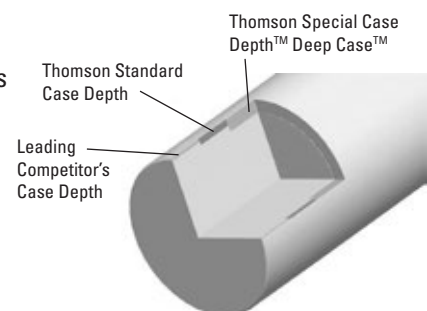



## Surface Finish

Surface is the key factor affecting travel life, load levels, frictional resistance and smoothness of travel. Thomson 60 Case® LinearRace® shafting is centerless ground for a consistent, smooth and industry leading cataloged surface finish of 8 Ra microinch max. Excellent surface finish and hardness maximize the efficiency and life of linear bearings, shaft riding seals and overall visual appearance. When 8 Ra microinch is not good enough, we can provide 6 Ra microinch surface finishes at an additional cost. Smoother equals longer bearing life.

## Roundness

Shaft roundness is vital for linear race applications such as spindles and guide rods where accuracy, life or precision is paramount. Roundness ensures uniform distribution of bearing loads for maximized bearing life, longer travel life and improved positional accuracy. Shafts that look round can be deceiving to the eye and anything but round when properly evaluated, using precision tracing techniques. Thomson 60 Case shaft roundness is within 0.000080" for Class L, S, D, M and .000050" for Class N. Our leading competitors don't catalog roundness and some are .0002". Rounder equals longer bearing life.

These two graphs taken from a roundness trace display

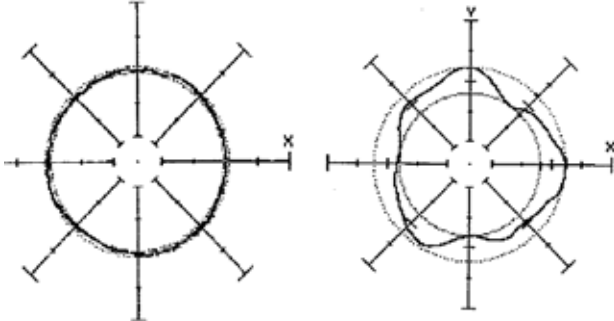

60 Case LinearRace  
Competitor Shafting  
the major roundness difference between Thomson 60 Case LinearRace shafting products and competitor shafting.

## Straightness

Straightness is the most vital parameter to positioning accuracy for a linear Ball Bushing® system. Thomson 60 Case shafts are straight within 0.001" per foot cumulative (TIR .002") when shipped from the factory. Handling or machining of shafting can cause the material to bend once they leave the factory. When straightness is critical, let Thomson provide the special machined shaft; let us machine and straighten the shaft for you using our proprietary straightening and measurement techniques.

Our leading competitor does not catalog straightness. Straighter equals higher precision.

60 Case LinearRace shafting is inspected to ensure that it meets the highest quality standards. Standard straightness for all 60 Case LinearRace shafting is .001 inch per foot (.025 mm/300 mm) cumulative (.002 inch [.05

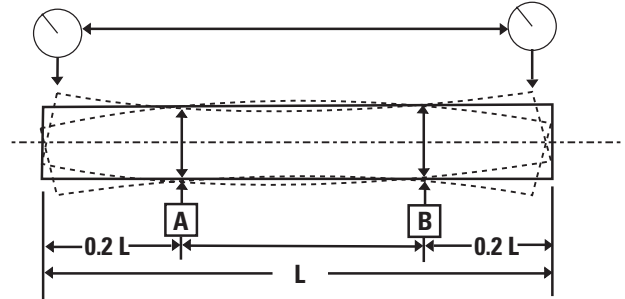

mm] TIR), with special straightness of .0005 inch per foot (.012 mm/300 mm) cumulative (.001 inch [.025 mm] TIR) available.

## Cylindricity

Cylindricity is a measure of the degree of conformance of the outside surface (diameter along the length of the shaft) to a true cylinder. True conformance (high cylindricity) ensures the benefits of roundness, diameter and straightness are present over the shaft length, or working surface, and not just in a particular location. This ensures uniform distribution of bearing loads, increases load capacity in the working area of the bearing, maximizes bearing life and increases travel life. Taper is a component of cylindricity and all Thomson 60 Case shafts are produced with a maximum taper of 1/2 the diameter tolerance over the entire length of the shaft.

In linear

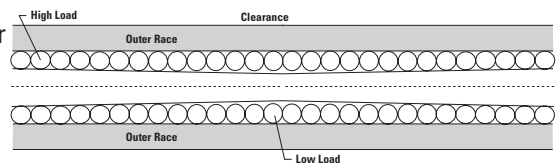

bearing applications, taper found in competitor shafting can cause one portion of the linear bearing to be loaded higher than the other. This can cause dramatic reduction in travel life or load capacity. As taper increases, balls go in and out of preload causing premature wear and reduction in travel life.

### Length Tolerance

Thomson 60 Case shafting can be cut to your specified length. It will have a standard length tolerance of  $\pm 1/32''$  for diameters less than 2 inches and  $\pm 1/16''$  for all larger diameters. Special length tolerances are available for an additional charge. All cut shafting is subject to a deburring process to remove sharp edges. The size of the standard chamfer is approximately  $1/32'' \times 45$  degrees for diameters less than 1" and  $1/16'' \times 45$  degrees for diameters 1" and larger. Special chamfer sizes can be provided for an additional charge.

### Predrilled and Tapped Holes

Thomson 60 Case shafting is stocked with radial holes drilled and tapped to accept a continuous shaft support rail in both carbon steel and 440C stainless steel. Continuous support prevents shaft deflection when used to support heavy loads or for long travel lengths.

### Precision Special Machining

Thomson 60 Case can be supplied specially machined to your drawing and/or application requirements. Leave your special machining needs to us. With more than 75 years of experience, we can provide a high-quality, special machined shaft to your specifications, allowing you to focus on your core competency. Fax us a detailed sketch or drawing and let our engineers provide you with a quotation. See page 207 for a sample of machining offered.



### Special Coatings

Thomson offers a variety of corrosion-resistant products to meet the needs of specific corrosive environments. Thomson 60 Case is available as thin dense chrome plated with plain ends from stock or 100% chrome plated, black oxide, or Armoloy™ plated to name a few. Contact our application engineering team or see page 208 for more information.

### How does Thomson 60 Case compare to our leading competitor shafting?

	Thomson	Competitor 1	Competitor 2
<b>Materials</b>	Carbon Steel	Carbon Steel	Carbon Steel
	440C SS	440C SS	440C SS or equiv.
	316 SS		52100 Tubular
	52100 Tubular		
<b>Tolerance Classes</b>	L, N, S, D, G, MM	L, S, MM	L, S, MM
<b>Case Depth</b>	.080"	.080"	.035"
<b>Surface Finish</b>	8 Ra microinch Max	10-12 RMS	12 RMS
<b>Roundness (L class)</b>	.000080"	not cataloged	.0002"
<b>Straightness</b>	.001"/foot	.001-.002"/foot .0012"	not cataloged
<b>Taper</b>	.0001"	not cataloged	.0004"



## 60 Case® LinearRace® Shafting for End-Supported Applications

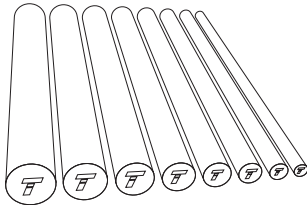

### Solid 60 Case LinearRace Shafting Features:

- Diameter range between 3/16 and 4 inch.
- Roundness 80 millionths of an inch.
- Case hardness 60 HRC minimum.
- Surface finish 8 Ra microinch.
- Available in corrosion-resistant 440C stainless steel (50 HRC minimum).
- Available with PrePlate™ chrome option.
- Standard straightness is .001 inch per foot cumulative (.002" TIR) with special straightness at .0005 inch per foot cumulative (.001" TIR) available.

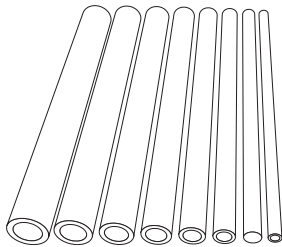

### 60 Case Tubular Lite™ LinearRace Shafting Features:

- Hollow inner diameter reduces weight and inertia.
- Diameter range between 3/4 and 4 inch.
- Roundness 80 millionths of an inch.
- Case hardness 58 HRC minimum.
- Surface finish 8 Ra microinch.
- Standard straightness is .001 inch per foot cumulative (.002" TIR) with special straightness at .0005 inch per foot cumulative (.001" TIR) available.

## 60 Case LinearRace Shafting (Predrilled) for Continuously Supported Applications

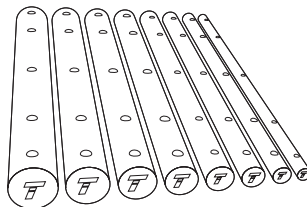

### Solid 60 Case LinearRace Shafting with Mounting Holes Features:

- Radial drilled and tapped holes ready for immediate use with standard hole spacing to match standard 60 Case LinearRace support rails.
- Diameter range between 1/2 and 4 inches, special machining (SM) required over 2 inches.
- Surface finish 8 Ra microinch.
- Hardness 60 HRC minimum.
- Roundness 80 millionths of an inch.
- Available in corrosion-resistant 440C stainless steel (50 HRC min).
- Available with Preplate chrome option.
- Standard straightness .001 inch per foot cumulative (.002" TIR) with special straightness at .0005 inch per foot cumulative (.001" TIR) available.

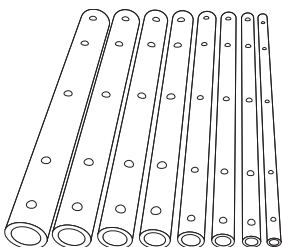

### 60 Case Tubular Lite LinearRace Shafting with Mounting Holes Features:

- Hollow design reduces weight and inertia.
- Can be supplied with radial drilled and tapped holes, ready for immediate use.
- Standard hole spacing to match standard 60 Case LinearRace support rails.
- Diameter range between 1 1/2 and 4 inch.
- Roundness 80 millionths of an inch.
- Case hardness 58 HRC minimum.
- Surface finish 8 Ra microinch.
- Standard straightness .001 inch per foot cumulative (.002" TIR) with special straightness at .0005 inch per foot cumulative (.001" TIR) available.

## 60 Case LinearRace Support Rails and Assemblies for Continuously Supported Applications

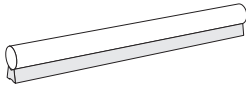

### LSR Low Profile 60 Case LinearRace Support Rail Features:

- Diameter range between 1/2 and 4 inch.
- Available with standard mounting holes for immediate use.
- Available without mounting holes for custom hole spacing.
- Low-profile design.
- Unlimited travel lengths.

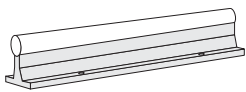

### SR 60 Case LinearRace Support Rail and SRA 60 Case LinearRace Support Rail Assembly Features:

- Diameter range between 1/2 and 2 inch.
- Available with standard mounting holes for immediate use.
- Available without mounting holes for customized hole spacing.
- Available as a pre-engineered, ready to install assembly.
- Lightweight, high-strength aluminum alloy rail.
- Unlimited travel lengths.

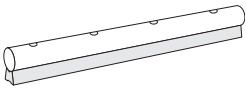

### LSRA Smart Rail\* Assembly Features:

- Diameter range between 5/8 and 1 1/2 inch.
- Bolt-down-from-the-top mounting.
- Single piece lengths up to 15 feet long.
- Low-profile design.

## 60 Case LinearRace Supports for End Supported Applications

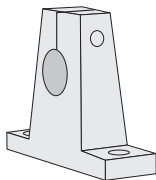

### SB 60 Case LinearRace Shafting End Support Block Features:

- Size range between 1/4 and 2 inch.
- Easily secured with two mounting bolts.
- Malleable iron alloy for sizes 1/2 to 2 inch diameter.
- Protected by corrosion-resistant coating.
- Lightweight, high-strength aluminum alloy construction for sizes 1/4 and 3/8 inch.

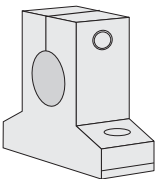

### ASB Low Profile 60 Case LinearRace Shafting End Support Block Features:

- Size range between 1/4 and 1 1/2 inch.
- Low profile design.
- Easily secured with two mounting bolts.
- Lightweight, high-strength aluminum alloy construction.

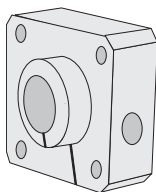

### FSB Flanged 60 Case LinearRace End Support Block Features:

- Available in 1/2, 3/4, 1 and 1 1/4 inch diameters.
- Flanged mounting surface for easy assembly.
- Easily secured with four mounting bolts.
- Designed specifically for use with Super Smart Flanged pillow blocks.
- Lightweight, high-strength aluminum alloy construction.



# Hardened and Ground 60 Case® Precision LinearRace® Shafting

## Part Number Description

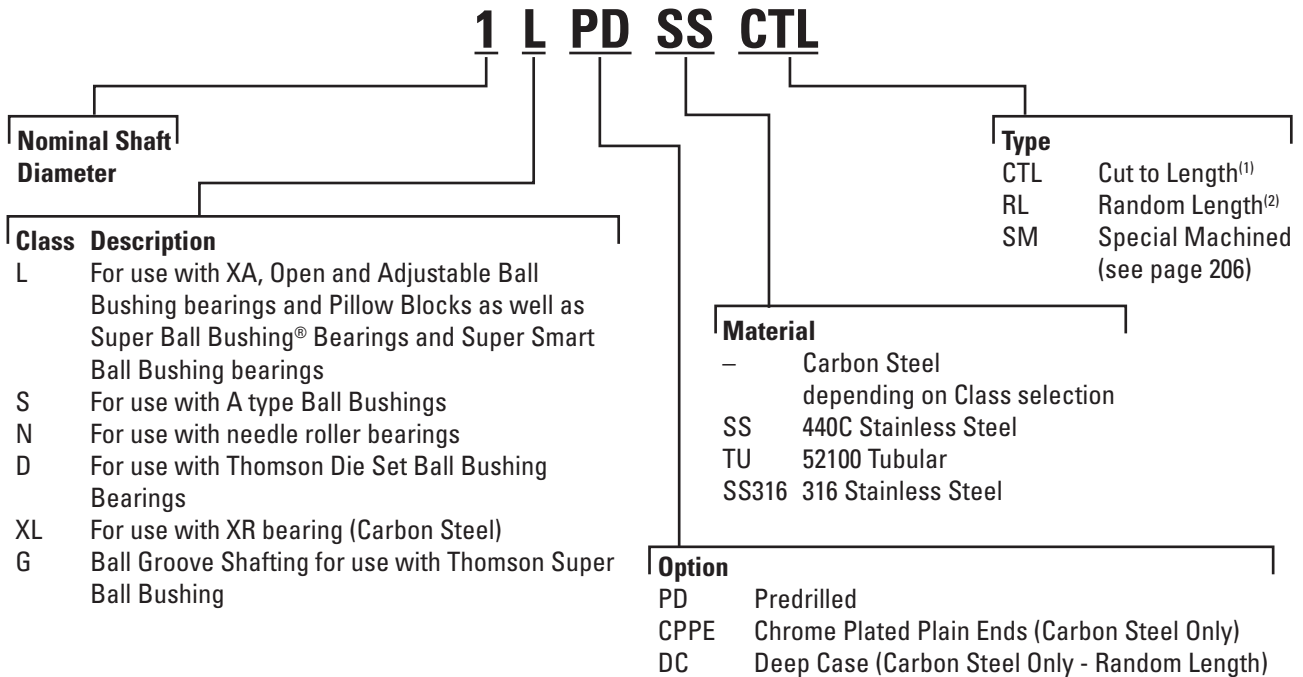

(1) CTL = Cut to length is Thomson 60 Case cut to your specified length.

(2) RL = Random length is full bar or long length shafting. It is called random length because we start with a raw bar 4" to 6" longer than the min. usable but guarantee only the min. usable. We mark the ends of what is out of our own tolerance. This is the result of the manufacturing process and tightly controlled roundness specifications.

Not all options are available in all sizes.

See catalog pages or contact Thomson Customer Support for combination availability.

For additional information on material options, see page 264.

## Look for the Brand Logo



If you specify Thomson, look for the logo. Do not be fooled when ordering linear shafting. All Thomson 60 Case LinearRace shafting is etched with the Thomson logo as shown in the picture. If the shaft you have does not have the logo, it may not be a true Thomson 60 Case. Thomson 60 Case is etched approximately every 18 to 22 inches.

### Solid Carbon Steel

Hardness: 60 ROCKWELL C Min.

Surface Finish: 8 Ra microinch Max

Roundness: .000080" Class L and S / .000050" Class N

Straightness: .001" Per Foot Cumulative (.002" TIR)

Taper: .0001"

Nominal Diameter (in)	Class L			Class S			Class N			Min. Hardness Depth (in)	Weight Per Inch (lb)
	Basic Part Number	Diameter Tolerance (in)	Max. Length (in)	Basic Part Number	Diameter Tolerance (in)	Max. Length (in)	Basic Part Number	Diameter Tolerance (in)	Max. Length (in)		
3/16"	3/16 L	.1870 .1865	54	—	—	—	—	—	—	.027 <sup>(1)</sup>	.008
1/4"	1/4 L	.2495 .2490	94	1/4 S	.2490 .2485	94	1/4 N	.2500 .2498	94	.027 <sup>(1)</sup>	.014
3/8"	3/8 L	.3745 .3740	166	3/8 S	.3740 .3735	166	3/8 N	.3750 .3748	166	.027	.031
1/2"	1/2 L	.4995 .4990	166	1/2 S	.4990 .4985	166	1/2 N	.5000 .4998	166	.040	.055
5/8"	5/8 L	.6245 .6240	202	5/8 S	.6240 .6235	202	5/8 N	.6250 .6248	202	.040	.086
3/4"	3/4 L	.7495 .7490	202	3/4 S	.7490 .7485	202	3/4 N	.7500 .7498	202	.060	.125
7/8"	7/8 L	.8745 .8740	202	—	—	—	7/8 N	.8750 .8748	202	.060	.170
1"	1 L	.9995 .9990	202	1 S	.9990 .9985	202	1 N	1.0000 .9998	202	.080	.222
1 1/8"	1 1/8 L	1.1245 1.1240	202	—	—	—	—	1.1250 1.1248	202	.080	.281
1 1/4"	1 1/4 L	1.2495 1.2490	202	1 1/4 S	1.2490 1.2485	202	1 1/4 N	1.2500 1.2498	202	.080	.348
1 3/8"	1 3/8 L	1.3745 1.3740	202	—	—	—	1 3/8 N	1.3750 1.3747	202	.080	.420
1 1/2"	1 1/2 L	1.4994 1.4989	202	1 1/2 S	1.4989 1.4984	202	1 1/2 N	1.5000 1.4997	202	.080	.500
1 5/8"	1 5/8 L	1.6245 1.6240	178	—	—	—	1 5/8 N	1.6250 1.6247	178	.080	.587
1 3/4"	1 3/4 L	1.7495 1.7490	178	—	—	—	1 3/4 N	1.7500 1.7497	178	.100	.681
2"	2 L	1.9994 1.9987	202	2 S	1.9987 1.9980	202	2 N	2.0000 1.9997	202	.100	.890
2 1/4"	2 1/4 L	2.2494 2.2487	202	—	—	—	2 1/4 N	2.2500 2.2497	202	.100	1.153
2 1/2"	2 1/2 L	2.4993 2.4985	202	2 1/2 S	2.4985 2.4977	202	2 1/2 N	2.5000 2.4996	202	.100	1.391
3"	3 L	2.9992 2.9983	202	3 S	2.9983 2.9974	202	3 N	3.0000 2.9996	202	.100	2.003
3 1/2"	3 1/2 L	3.4990 3.4980	202	—	—	—	—	—	—	.100	2.726
4"	4 L	3.9988 3.9976	202	4 S	3.9976 3.9964	202	—	—	—	.100	3.560

1. Shaft may be thru hardened due to small diameter.

### Solid Carbon Steel

Hardness: 60 ROCKWELL C Min.

Roundness: .000080" Class D and XL

Straightness: .001" Per Foot Cumulative (.002" TIR)

Taper: .0001"

Nominal Diameter (in)	Class D			Min. Hardness Depth (in)	Weight Per Inch (lb)
	Basic Part Number	Diameter Tolerance (in)	Surface Finish		
1"	1 D	1.0003 1.0000	8 Ra μin. Max.	202	.222
1 1/4"	1 1/4 D	1.2503 1.2500	8 Ra μin. Max.	202	.348
1 1/2"	1 1/2 D	1.5003 1.5000	8 Ra μin. Max.	202	.500
2"	2 D	2.0003 2.0000	8 Ra μin. Max.	202	.890

Nominal Diameter (in)	Class XL			Min. Hardness Depth (in)	Weight Per Inch (lb)
	Basic Part Number	Diameter Tolerance (in)	Surface Finish		
2"	2 XL	1.9994 1.9991	4-8 Ra μin. Max.	202	.890
3"	3 XL	2.9992 2.9989	4-8 Ra μin. Max.	202	2.003
4"	4 XL	3.9988 3.9983	6-10 Ra μin. Max.	202	3.560



## Standard Options for Carbon Steel Shafting

### Chrome Plated Plain Ends (CPPE)<sup>(1)</sup>, Predrilled (PD), Predrilled Chrome Plated Plain Ends (PDCPPE), Solid Steel

Hardness: 60 ROCKWELL C Min.

Surface Finish: 8 Ra microinch Max

Roundness: .000080"

Straightness: .001" Per Foot Cumulative (.002" TIR)

Taper: .0001"

Nominal Diameter (in)	Chrome Plated Plain Ends			Min. Hardness Depth (in)	Weight Per Inch (lb)
	Part Number	Tolerance Class L	Max. Length (in)		
1/2"	1/2 L CPPE	.4995	166	.040	.055
		.4990			
5/8"	5/8 L CPPE	.6245	202	.040	.086
		.6240			
3/4"	3/4 L CPPE	.7495	202	.060	.125
		.7490			
1"	1 L CPPE	.9995	202	.080	.222
		.9990			
1 1/4"	1 1/4 L CPPE	1.2495	202	.080	.348
		1.2490			
1 1/2"	1 1/2 L CPPE	1.4994	202	.080	.500
		1.4989			
2"	2 L CPPE	1.9994	202	.100	.890
		1.9987			

(1) CPPE - Chrome Plated Plain Ends, which means ends and chamfers, are not plated. Completely plated chamfers are available as a special machine part. See page 206.

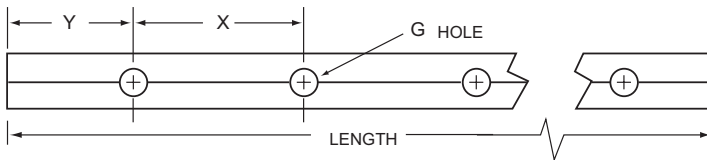

Nominal Diameter (in)	Predrilled		Predrilled Chrome Plated		Hole Spacing X (inch +/- 1/64) (noncumulative)	G Standard Thread Size	Length Tolerance (in)	Max. Length (in)	Min. Hardness Depth (in)	Weight Per Inch (lb)
	Part Number Predrilled	L PD Tolerance Class	Part Number Predrilled Chrome Plated Ends	L PD Tolerance Class						
1/2"	1/2 L PD	.4995	1/2 L PDCPPE	.4995	4	#6-32	+/- 1/32	166	.040	.055
		.4990		.4990						
5/8"	5/8 L PD	.6245	5/8 L PDCPPE	.6245	4	#8-32	+/- 1/32	178	.040	.086
		.6240		.6240						
3/4"	3/4 L PD	.7495	3/4 L PDCPPE	.7495	6	#10-32	+/- 1/32	178	.060	.125
		.7490		.7490						
1"	1 L PD	.9995	1 L PDCPPE	.9995	6	1/4-20	+/- 1/32	178	.080	.222
		.9990		.9990						
1 1/4"	1 1/4 L PD	1.2495	1 1/4 L PDCPPE	1.2495	6	5/16-18	+/- 1/32	178	.080	.348
		1.2490		1.2490						
1 1/2"	1 1/2 L PD	1.4994	1 1/2 L PDCPPE	1.4994	8	3/8-16	+/- 1/32	178	.080	.500
		1.4989		1.4989						
2"	2 L PD	1.9994	2 L PDCPPE	1.9994	8	1/2-13	+/- 1/16	178	.100	.890
		1.9987		1.9987						

Holes are drilled and tapped to the center of the shaft. Y = distance from end of rail to the center of first mounting hole, Y1 = Y2 unless specified. Chrome plating is thin, dense chrome with thickness of .00005 - .0001".

### Solid Steel Deep Case - Available in Random Length Only

Hardness: 60 ROCKWELL C Min.

Straightness: .001" Per Foot Cumulative (.002" TIR)

Surface Finish: 8 Ra microinch Max

Taper: .0001"

Roundness: .000080" Class L and S / .000050" Class N

Nominal Diameter (in)	Class L Deep Case			Class N Deep Case			Min. Hardness Depth (in)	Weight Per Inch (lb)
	Basic Part Number	Diameter Tolerance (in)	Max. Length (in)	Basic Part Number	Diameter Tolerance (in)	Max. Length (in)		
3/4"	3/4 L DC	.7495	202	3/4 N DC	.7500	202	.120	.125
		.7490			.7498			
7/8"	7/8 L DC	.8745	202	7/8 N DC	.8750	202	.120	.170
		.8740			.8748			
1"	1 L DC	.9995	202	1 N DC	1.0000	202	.160	.222
		.9990			.9998			
1 1/8"	1 1/8 L DC	1.1245	202	1 1/8 N DC	1.1250	202	.160	.281
		1.1240			1.1248			
1 1/4"	1 1/4 L DC	1.2495	202	1 1/4 N DC	1.2500	202	.180	.348
		1.2490			1.2498			
1 1/2"	1 1/2 L DC	1.4994	202	1 1/2 N DC	1.5000	202	.180	.500
		1.4989			1.4997			
1 3/4"	1 3/4 L DC	1.7495	178	1 3/4 N DC	1.7500	178	.250	.681
		1.7490			1.7497			
2"	2 L DC	1.9994	202	2 N DC	2.0000	202	.250	.890
		1.9987			1.9997			
2 1/4"	2 1/4 L DC	2.2494	202	2 1/4 N DC	2.2500	202	.250	1.153
		2.2487			2.2497			
2 1/2"	2 1/2 L DC	2.4993	202	2 1/2 N DC	2.5000	202	.250	1.391
		2.4985			2.4996			
3"	3 L DC	2.9992	202	3 N DC	3.0000	202	.250	2.003
		2.9983			2.9996			
3 1/2"	3 1/2 L DC	3.4990	202	-	-	-	.250	2.726
		3.4980			-			

### Ball Groove LinearRace Shaft - Solid Carbon Steel

Hardness: 60 ROCKWELL C Min.

Surface Finish: 8 Ra microinch Max

Roundness: .000080"

Straightness: Shaft Groove .002" Per Foot Cumulative (.002" TIR)

Taper: .0001"

Nominal Diameter (in)	Basic Part Number	Class G		Min. Hardness Depth (in)	Weight Per Inch (lb)
		Diameter Tolerance (in)	Max. Length (in)		
1/4"	1/4 G	.2495	45	.027 <sup>(1)</sup>	.014
		.2490			
3/8"	3/8 G	.3745	45	.027	.031
		.3740			
1/2"	1/2 G	.4995	45	.040	.055
		.4990			
5/8"	5/8 G	.6245	45	.040	.086
		.6240			
3/4"	3/4 G	.7495	45	.060	.125
		.7490			
1"	1 G	.9995	45	.080	.222
		.9990			

1. Shaft may be thru hardened due to small diameter.



## 440C Stainless Steel<sup>(1)</sup>

Hardness: 50 ROCKWELL C Min.

Surface Finish: 8 Ra microinch Max

Roundness: .000080"

Straightness: .001" Per Foot Cumulative (.002" TIR)

Taper: .0001"

Nominal Diameter (in)	Class L			Class S			Min. Hardness Depth (in)	Weight Per Inch (lb)
	Basic Part Number	Diameter Tolerance (in)	Max. Length (in)	Basic Part Number	Diameter Tolerance (in)	Max. Length (in)		
3/16"	3/16 L SS	.1870 .1865	54	—	—	—	.027 <sup>(2)</sup>	.008
1/4"	1/4 L SS	.2495 .2490	94	1/4 S SS	.2490 .2485	94	.027 <sup>(2)</sup>	.014
3/8"	3/8 L SS	.3745 .3740	178	3/8 S SS	.3740 .3735	178	.027 <sup>(2)</sup>	.031
1/2"	1/2 L SS	.4995 .4990	178	1/2 S SS	.4990 .4985	178	.040	.055
5/8"	5/8 L SS	.6245 .6240	178	5/8 S SS	.6240 .6235	178	.040	.086
3/4"	3/4 L SS	.7495 .7490	178	3/4 S SS	.7490 .7485	178	.060	.125
1"	1 L SS	.9995 .9990	178	1 S SS	.9990 .9985	178	.080	.222
1 1/4"	1 1/4 L SS	1.2495 1.2490	178	1 1/4 S SS	1.2490 1.2485	178	.080	.348
1 1/2"	1 1/2 L SS	1.4994 1.4989	178	1 1/2 S SS	1.4989 1.4984	178	.080	.500
2"	2 L SS	1.9994 1.9987	178	2 S SS	1.9987 1.9980	178	.100	.890
2 1/2"	2 1/2 L SS	2.4993 2.4985	178	2 1/2 S SS	2.4985 2.4977	178	.100	1.391

1. 440C stainless is "corrosion resistant"; it contains some carbon which allows for hardening. Carbon can result in corrosion over time.

2. Shaft may be thru hardened due to small diameter.

## Standard Options for 440C Stainless Steel Predrilled (PD)

Hardness: 50 ROCKWELL C Min.

Surface Finish: 8 Ra microinch Max

Roundness: .000080"

Straightness: .001" Per Foot Cumulative (.002" TIR)

Taper: .0001"

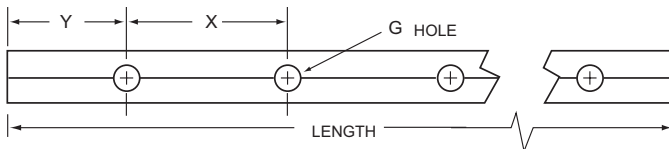

Nominal Diameter (in)	Predrilled		Hole Spacing	G Standard Thread Size	Length Tolerance (in)	Max. Length (in)	Min. Hardness Depth (in)	Weight Per Inch (lb)
	Part Number Predrilled	L PD Tolerance Class	X (inch +/- 1/64) (noncumulative)					
1/2"	1/2 L PD SS	.4995 .4990	4	#6-32	+/- 1/32	166	.040	.055
5/8"	5/8 L PD SS	.6245 .6240	4	#8-32	+/- 1/32	178	.040	.086
3/4"	3/4 L PD SS	.7495 .7490	6	#10-32	+/- 1/32	178	.060	.125
1"	1 L PD SS	.9995 .9990	6	1/4-20	+/- 1/32	178	.080	.222
1 1/4"	1 1/4 L PD SS	1.2495 1.2490	6	5/16-18	+/- 1/32	178	.080	.348
1 1/2"	1 1/2 L PD SS	1.4994 1.4989	8	3/8-16	+/- 1/32	178	.080	.500
2"	2 L PD SS	1.9994 1.9987	8	1/2-13	+/- 1/16	178	.100	.890

Holes are drilled and tapped to the center of the shaft. Y = distance from end of rail to the center of first mounting hole, Y1 = Y2 unless specified.

### Ball Groove LinearRace Shaft - 440C Stainless Steel

Hardness: 50 ROCKWELL C Min.  
 Surface Finish: 8 Ra microinch Max  
 Roundness: .000080"

Straightness: Shaft Groove .002" Per Foot Cumulative  
 Taper: .0001"

Nominal Diameter (in)	Basic Part Number	Class G		Min. Hardness Depth (in)	Weight Per Inch (lb)
		Diameter Tolerance (in)	Max. Length (in)		
1/4"	1/4 G SS	.2495	45	.027 <sup>(1)</sup>	.014
		.2490			
3/8"	3/8 G SS	.3745	45	.027 <sup>(1)</sup>	.031
		.3740			
1/2"	1/2 G SS	.4995	45	.040	.055
		.4990			
5/8"	5/8 G SS	.6245	45	.040	.086
		.6240			
3/4"	3/4 G SS	.7495	45	.060	.125
		.7490			
1"	1 G SS	.9995	45	.080	.222
		.9990			

1. Shaft may be thru hardened due to small diameter.

### Instrument 440C Stainless Steel LinearRace<sup>®</sup> shafting for use with Thomson Instrument Ball Bushing<sup>®</sup> Bearings

Hardness: 55 ROCKWELL C Thru Hardened  
 Surface Finish: 4 Ra microinch Max  
 Roundness: .000080"

Straightness: .0001" Per Inch Cumulative  
 Taper: .0001"

Nominal Diameter (in)	Basic Part Number	INST Class		Max. Length (in)	Weight Per Inch (lb)
		Diameter Tolerance (in)	Length Tolerance (in)		
1/8"	INST2MS0L	.1248	+/- .005	12	.004
		.1247			
3/16"	INST3MS0L	.1873	+/- .005	12	.008
		.1872			
1/4"	INST4MS0L	.2498	+/- .005	12	.014
		.2497			

### 52100 Tubular

Hardness: 58 ROCKWELL C Min.  
 Surface Finish: 8 Ra microinch Max  
 Roundness: .000080" Class L and S

Straightness: .001" Per Foot Cumulative (.002" TIR)  
 Taper: .0001"

Nominal Diameter (in)	Nominal I.D. (in)	Class L			Class S			Min. Hardness Depth (in)	Weight Per Inch (lb)
		Basic Part Number	Diameter Tolerance (in)	Max. Length (in)	Basic Part Number	Diameter Tolerance (in)	Max. Length (in)		
3/4"	.46	3/4 L TU	.7495	174	3/4 S TU	.7490	174	.060	.0754
	.42		.7490			.7485			
1"	.63	1 L TU	.9995	174	1 S TU	.9990	174	.080	.158
	.57		.9990			.9985			
1 1/2"	.93	1 1/2 L TU	1.4994	174	1 1/2 S TU	1.4989	174	.080	.328
	.85		1.4989			1.4984			
2"	1.32	2 L TU	1.9994	174	2 S TU	1.9987	174	.100	.542
	1.19		1.9987			1.9980			
2 1/2"	1.84	2 1/2 L TU	2.4993	174	2 1/2 S TU	2.4985	174	.100	.749
	1.66		2.4985			2.4977			
3"	2.20	3 L TU	2.9992	174	3 S TU	2.9983	174	.100	1.112
	1.80		2.9983			2.9974			
4"	3.30	4 L TU	3.9988	174	4 S TU	3.9976	174	.100	1.558
	2.70		3.9976			3.9964			



### 316 Stainless Steel<sup>(1)</sup>

Hardness: 20-25 ROCKWELL C Min.  
 Surface Finish: 8 Ra microinch Max  
 Roundness: .000080"  
 Straightness: .001" Per Foot Cumulative (.002" TIR)  
 Taper: .0001"

Nominal Diameter (in)	Basic Part Number	Class L		Weight Per Inch (lb)
		Diameter Tolerance (in)	Max. Length (in)	
1/4"	1/4 L SS316	.2495	94	.014
		.2490		
3/8"	3/8 L SS316	.3745	138	.031
		.3740		
1/2"	1/2 L SS316	.4995	138	.055
		.4990		
5/8"	5/8 L SS316	.6245	138	.086
		.6240		
3/4"	3/4 L SS316	.7495	138	.125
		.7490		
1"	1 L SS316	.9995	138	.222
		.9990		
1 1/4"	1 1/4 L SS316	1.2495	138	.348
		1.2490		
1 1/2"	1 1/2 L SS316	1.4994	138	.500
		1.4989		
2"	2 L SS316	1.9994	138	.890
		1.9987		

(1) 316 Stainless Steel is corrosion-proof steel and has no carbon content that will result in corrosion.

### Standard Options for 316 Stainless Steel Predrilled (PD)

Hardness: 20-25 ROCKWELL C Min.  
 Surface Finish: 8 Ra microinch Max  
 Roundness: .000080"  
 Straightness: .001" Per Foot Cumulative (.002" TIR)  
 Taper: .0001"

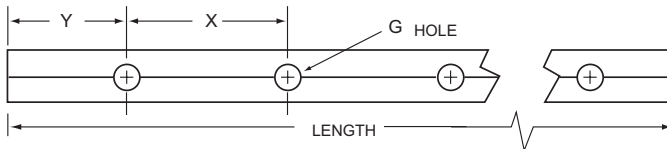

Nominal Diameter (in)	Predrilled		Hole Spacing X (inch +/- 1/64) (noncumulative)	G Standard Thread Size	Length Tolerance (in)	Max. Length (in)	Weight Per Inch (lb)
	Part Number Predrilled	LPD Tolerance Class					
1/2"	1/2 L SS316PD	.4995	4	#6-32	+/- 1/32	138	.055
		.4990					
5/8"	5/8 L SS316PD	.6245	4	#8-32	+/- 1/32	138	.086
		.6240					
3/4"	3/4 L SS316PD	.7495	6	#10-32	+/- 1/32	138	.125
		.7490					
1"	1 L SS316PD	.9995	6	1/4-20	+/- 1/32	138	.222
		.9990					
1 1/4"	1 1/4 SS316PD	1.2495	6	5/16-18	+/- 1/32	138	.348
		1.2490					
1 1/2"	1 1/2 SS316PD	1.4994	8	3/8-16	+/- 1/32	138	.500
		1.4989					
2"	2 L SS316PD	1.9994	8	1/2-13	+/- 1/16	138	.890
		1.9987					

Holes are drilled and tapped to the center of the shaft. Y = distance from end of rail to the center of first mounting hole, Y1 = Y2 unless specified.

# Support Rails and Assemblies for Continuously Supported Applications

## Part Number Description

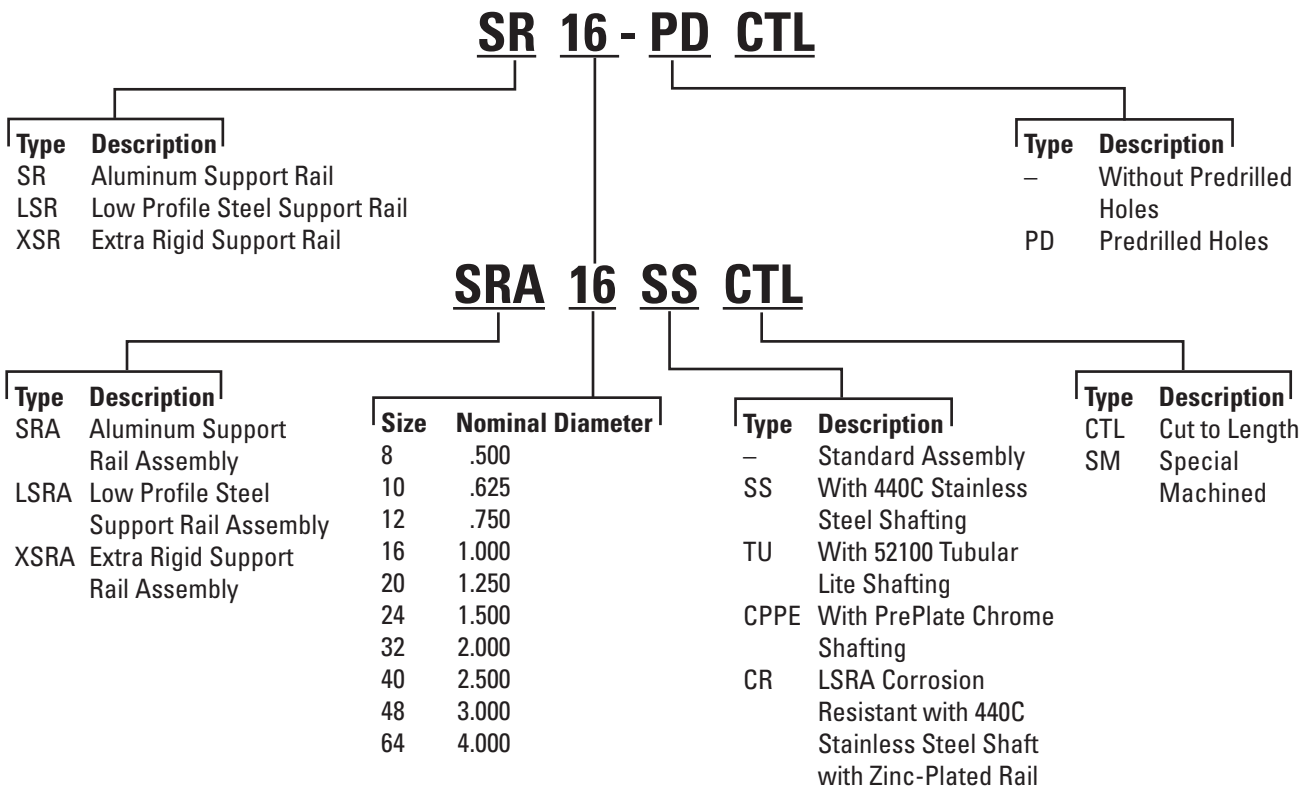

Not all options are available in all sizes.  
 See catalog pages or contact Thomson Customer Support for combination availability.  
 For additional information on material options, see page 264.



## Shaft Rail Supports Type SR & SR-PD

### The low-cost way of mounting Thomson 60 Case® shafts

Shaft supports simplify mounting of Thomson 60 Case shafts. Users of Thomson 60 Case shafting should carefully consider the use of these low-cost shaft supports. They are standard, available from stock, and simplify shaft mounting. In addition to other benefits, they eliminate many problems encountered in designing and manufacturing shaft-supporting devices. These versatile mounts can be used horizontally or vertically, and in many different arrangements. Shaft support rails are available without predrilled holes (SR), or predrilled (SR-PD) shaft rails to support 1/2-inch- through 2-inch-diameter shafts are available in standard 24-, 48- and 72-inch lengths<sup>(1)</sup>. Where shorter lengths are needed, rails are easily cut to length. For longer shafts, they can be mounted end to end, using shims or grout, if necessary, to compensate for slight variation within manufacturing tolerance. Thomson offers shaft support rails with pre-drilled holes to simplify shaft mounting.

## Low Shaft Support Rails Type LSR & LSR-PD

### For compact designs

Low shaft rails allow the design of more compact linear motion systems. The height from the base to the mean shaft center ranges from 9/16 inch for supporting a 1/2-inch-diameter shaft to a maximum 3 1/2 inches when supporting a 4-inch-diameter shaft – 40% lower than standard support rails. Low shaft rails are made of steel to maintain optimum shaft rigidity. Either continuous or intermittent support is possible when using Thomson open-type linear ball bearings. Low shaft rails are furnished in standard 4-foot lengths. Where shorter lengths are required, rails can easily be cut. For supporting longer shafts, rails can be mounted end to end without limit. Low shaft rails are available without pre-drilled mounting holes (LSR) or with predrilled mounting holes (LSR-PD) to match Thomson drilled and tapped shafts (PD).

When using LSR-PD, the attachment bolts are underneath, so you must have access under your machine base plate.

The LSRA assemblies highlighted below

utilize attachment bolts from above. If one of the standard predrilled low shaft rails is not appropriate for your design needs, low shaft rails can be custom drilled by Thomson to your specifications. Send a print with all required dimensions, tolerances and quantities needed to our application engineering team.

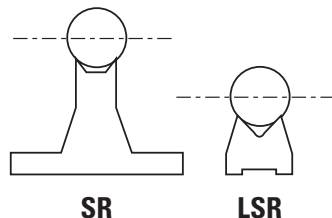

## Extra-Rigid Shaft Support Rails

### For XR Ball Bushing® bearing systems

Extra-rigid shaft support rails (XSR) are designed specifically for use with our extra-rigid Series XR Ball Bushing® Bearings. XSR support rails are available in nominal 24-inch lengths and are made of ductile iron and powder epoxy coated to provide the most deflection-resistant shaft support of all Thomson supports. To facilitate quick and easy installation, each extra-rigid shaft support is drilled and counter-bored for securing a drilled and tapped shaft into it and for bolting it to a flat, rigid base. For supporting long shafts, XSR support rails can be mounted end-to-end.

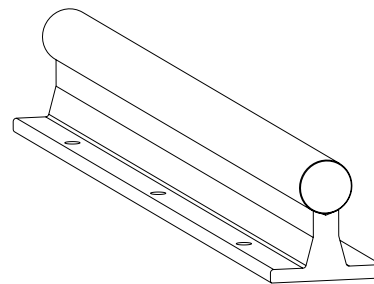

SRA

## Pre-Assembled Shaft Rail Assemblies Type SRA & LSRA

Thomson 60 Case steel shafts mounted on shaft support rails are now available for instant bolt-down installation. Assemblies are supplied cut to any length with no limit on the overall length (long lengths are butt jointed together unless specified otherwise). Either solid or lightweight tubular shafting can be assembled to the standard Thomson support rails, which come with base mounting holes spaced evenly along the overall length of the assembly. The LSRA uses a special shaft unlike the LSR-PD. The attachment bolts for the LSRA are from the top down so you can easily mount into a machine base plate. The LSRA bolt pattern closely matches profile rail linear guides and can easily be used as a drop-in substitute to replace linear guides (ensure you review loading requirements). Corrosion-resistant lower support rail assemblies (LSRA) are available. The support is zinc plated and shaft is 440C.

(1) Maximum continuous length is 71.94"

# Support Rails and Assemblies for Continuously Supported Applications

## Type SR/SR-PD 60 Case LinearRace Support Rails and Assemblies (Dimensions in inches)

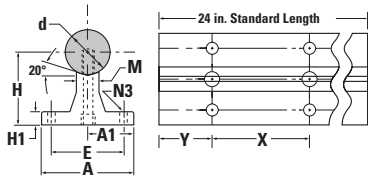

Material: Unfinished Aluminum Alloy

SR Without Holes	SR-PD With Predrilled Holes	Nominal LinearRace Diameter d	H ±.002	H1	A	A1	E	M	N3		LinearRace Mounting Bolt N1 (PD only)	X	Weight lb/ft
									Hole	Bolt			
SR8	SR8-PD	.500	1.125	.19	1.50	.750	1.00	.25	.17	#6	#6-32 x .88	4	.57
SR10	SR10-PD	.625	1.125	.25	1.63	.813	1.13	.31	.19	#8	#8-32 x .88	4	.70
SR12	SR12-PD	.750	1.500	.25	1.75	.875	1.25	.38	.22	#10	#10-32 x 1.25	6	.94
SR16	SR16-PD	1.000	1.750	.25	2.13	1.063	1.50	.50	.28	1/4	1/4-20 x 1.5	6	1.27
SR20	SR20-PD	1.250	2.125	.31	2.50	1.250	1.88	.56	.34	5/16	5/16-18 x 1.75	6	1.77
SR24	SR24-PD	1.500	2.500	.38	3.00	1.500	2.25	.69	.34	5/16	3/8-16 x 1.75	8	2.52
SR32	SR32-PD	2.000	3.250	.50	3.75	1.875	2.75	.88	.406	3/8	1/2-13 x 2.50	8	4.09

N1 Hole Dia. includes counterbore for socket head cap screw. Alignment and location of holes are ±.010", noncumulative. Y = distance from end of rail to the center of first mounting hole, Y1 = Y2 unless specified.

## Type LSR and LSR-PD 60 Case LinearRace Support Rails (Dimensions in inches)

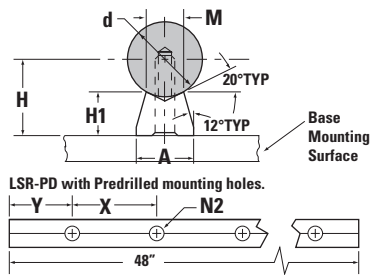

Material: Unfinished Steel Alloy

LSR Standard Without Holes	LSR-PD Standard w/Predrilled Holes	Nominal LinearRace Diameter d	H ±.002	H1	A	M	N2		N1	X	Weight lb/ft
							Hole	Bolt			
LSR-8	LSR-8-PD	.500	.562	.34	.37	.25	.17	#6	4	.33	
LSR-10	LSR-10-PD	.625	.687	.41	.45	.31	.19	#8	4	.50	
LSR-12	LSR-12-PD	.750	.750	.42	.51	.38	.22	#10	6	.58	
LSR-16	LSR-16-PD	1.000	1.000	.56	.69	.50	.28	1/4	6	1.03	
LSR-20	LSR-20-PD	1.250	1.187	.63	.78	.56	.34	5/16	6	1.30	
LSR-24	LSR-24-PD	1.500	1.375	.70	.93	.69	.41	3/8	8	1.72	
LSR-32	LSR-32-PD	2.000	1.750	.845	1.180	.875	.531	1/2	8	2.60	
LSR-40	LSR-40-PD	2.500	2.250	1.125	1.500	1.125	.687	5/8	8	4.49	
LSR-48	LSR-48-PD	3.000	2.750	1.404	1.875	1.375	.812	3/4	8	6.92	
LSR-64	LSR-64-PD	4.000	3.500	1.750	2.500	1.875	1.060	1	8	11.36	

Not for use with PB-OPN pillow blocks. Y = distance from end of rail to the center of first mounting hole, Y1 = Y2 unless specified.

## Type XSR Shaft Support Rails (Dimensions in inches)

Part Number	Nominal Shaft Diameter	A† ±.000/-001	B	C	D	E	Screw Diameter	F	C Bore	Recommended Screw	G Hole	C Bore	H Degrees	Weight lb/ft
								Hole						
XSR32	2	2.750	4-1/2	7/8	1	3-1/8	1/2	9/16	1 x 5/8 DP	1/2-13 x 2	9/16	1 x 3/4 DP	15	14.92
XSR48	3	4.000	6	1-1/4	1-5/16	4-1/4	5/8	11/16	1 1/4 x 3/4 DP	3/4-10 x 2-3/4	13/16	1 7/16 x 1 1/8 DP	25	29.03

† Centerline of shaft will be parallel to base within .0005. Surface dimensions as cast

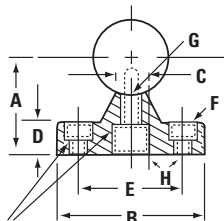

Lock washers recommended

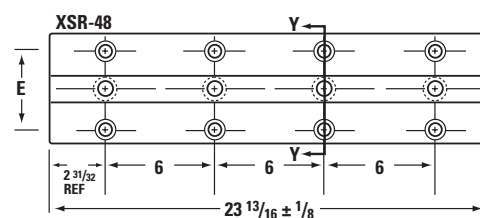
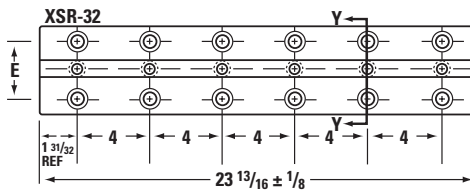

Material: Painted Ductile Iron



### Standard Shaft Rail Assemblies (Dimensions in inches)

Assembly Number			Nominal Linear Bearing Race Dia.	Dimensions							Base Holes		Weight lb/ft <sup>(1)</sup>	
With Solid Carbon Steel Shaft	With Solid Stainless Steel Shaft	With Tubular 52100		A ±.002	B	C	D	E	F		X	SRA and SRA-SS	SRA-TU	
									Bolt	Hole				
SRA-8	SRA-8-SS	—	1/2	1.125	1 1/2	1/4	3/16	1	#6	.169	4	1.23	—	
SRA-10	SRA-10-SS	—	5/8	1.125	1 5/8	5/16	1/4	1 1/8	#8	.193	4	1.74	—	
SRA-12	SRA-12-SS	SRA-12-TU	3/4	1.500	1 3/4	3/8	1/4	1 1/4	#10	.221	6	2.44	1.85	
SRA-16	SRA-16-SS	SRA-16-TU	1	1.750	2 1/8	1/2	1/4	1 1/2	1/4	.281	6	3.94	3.17	
SRA-20	SRA-20-SS	—	1 1/4	2.125	2 1/2	9/16	5/16	1 7/8	5/16	.343	6	5.95	—	
SRA-24	SRA-24-SS	SRA-24-TU	1 1/2	2.500	3	11/16	3/8	2 1/4	5/16	.343	8	8.52	6.46	
SRA-32	SRA-32-SS	SRA-32-TU	2	3.250	3 3/4	7/8	1/2	2 3/4	3/8	.406	8	14.77	10.59	

(1) Assembly weights do not include hardware.

Support Rail Material: Unfinished aluminum alloy extrusion. Base mounting hole locations are within ±.010 (noncumulative).

Notes: Lengths longer than 48" will use end to end support rails. Y = distance from end of rail to the center of first mounting hole, Y1 = Y2 unless specified.

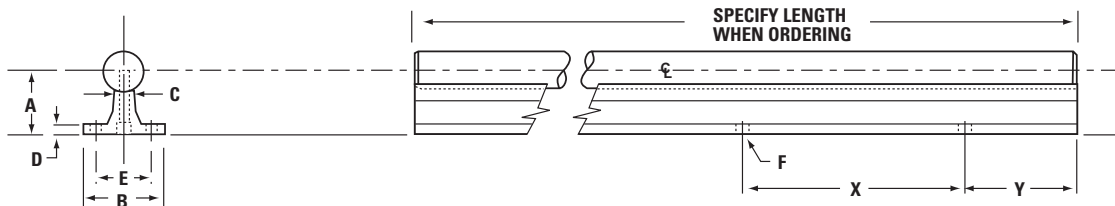

### Type LSRA 60 Case® Smart Rail Guides (Dimensions in inches)

Part Number <sup>(3)</sup>		LinearRace Shafting Diameter	H ±.002	A	A1	A2	Mounting Holes		Weight lb/ft <sup>(4)</sup>
Smart Rail Assembly <sup>(1)</sup>	Smart Rail Assembly <sup>(2)</sup>						X	N	
LSRA10	LSRA10 CR	.625	.687	.45	.225	.31	2	#5	1.49
LSRA12	LSRA12 CR	.750	.750	.51	.255	.38	3	#6	2.04
LSRA16	LSRA16 CR	1.000	1.000	.69	.345	.5	3	#10	3.61
LSRA20	LSRA20 CR	1.250	1.187	.78	.390	.56	3	5/16	5.20
LSRA24	LSRA24 CR	1.500	1.375	.93	.465	.69	4	3/8	7.37

(1) Consists of black oxide steel rail and high carbon steel LinearRace shafting (HRC 60 min.).

(2) Consists of zinc plated steel rail and 440C stainless steel LinearRace shafting (HRC 50 min.).

(3) Specify length of assembly when ordering. For example, LSRA12CR x 24.00 inches. Y dimension is equal on each end unless specified by customer.

(4) Assembly weights do not include hardware.

NOTE: LSRA's do not use standard "PD" shafting. The shafting requires a different hole pattern and configuration.

NOTE: Use only with Super Smart open pillow blocks.

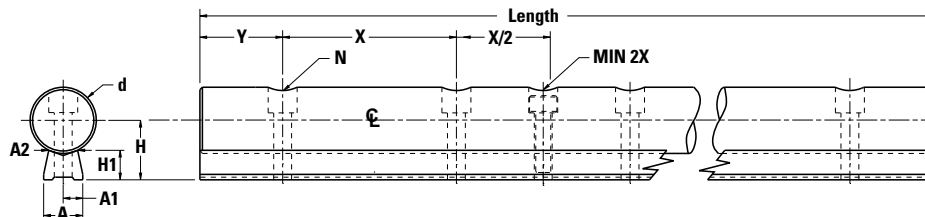

### XSRA Extra Rigid Shaft Rail Assemblies (Dimensions in inches)

Assembly Number		LinearRace Shafting Diameter	Dimensions							Base Holes		Weight lb/ft <sup>(1)</sup>	
With Solid Carbon Steel Shaft	With Tubular Carbon Steel Shaft		A +.000/-001	B	C	D	E	F			X	XSRA	XSRA-TU
								Screw Dia.	Hole	C Bore			
XSRA-32	XSRA-32-TU	2	2.750	4 1/2	7/8	1	3 1/8	1/2	9/16	1 x 5/8 DP	4	25.60	21.42
XSRA-48	XSRA-48-TU	3	4.000	6	1 1/4	1 5/16	4 1/4	5/8	11/16	1 1/4 x 3/4 DP	6	53.07	42.38

(1) Assembly weights do not include hardware.

Note: Lengths longer than 24" will use end to end support rails. Y = distance from end of rail to the center of first mounting hole, Y1 = Y2 unless specified.

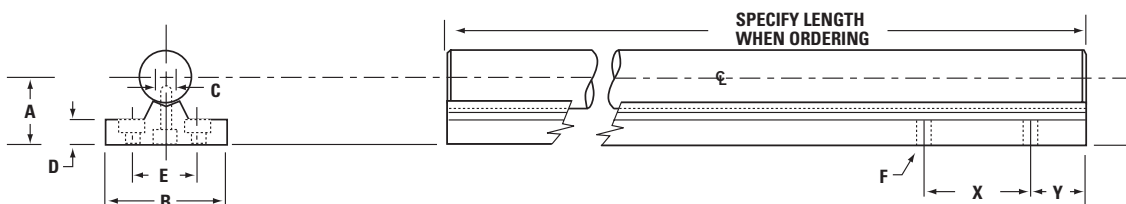

## Support Blocks for End Supported Applications

### Part Number Description

## ASB 16

Type	Description	Size	Nominal Diameter
ASB	Low Profile 60 Case LinearRace® End Support Block	4	.250
SB	Standard 60 Case LinearRace End Support Block	6	.375
FSB	Flanged 60 Case LinearRace End Support Block	8	.500
		10	.625
		12	.750
		16	1.000
		20	1.250
		24	1.500
		32	2.000
		48	3.000
		64	4.000

All sizes are not available for all support block types.  
See specific product charts for size availability.



## Shaft Support Blocks – Type SB and ASB

### For end support or intermittent support

Shaft support blocks are used for end or intermittent support where loads are light and deflection between supports is not a problem. Unlike shaft support rails, blocks do not permit longitudinal passage of open-type Ball Bushing® Bearings. Type SB shaft support blocks enable clamping of shafts and eliminate the need for bolts, etc. to maintain shaft position. Shimming is suggested for high-precision applications to eliminate the effect of variations in surface of base or manufacturing tolerances between supports.



Type ASB shaft blocks, manufactured from high-strength, extruded aluminum, provide either end or intermittent support in applications where loads are designed with a reference edge on one side of the base. This provides a surface parallel to the center of the shaft within  $\pm.001''$  that can be used to simplify shaft alignment.

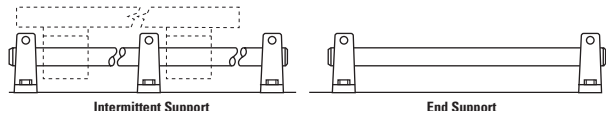

### Type SB 60 Case® LinearRace® Shaft End Support Blocks (Dimensions in inches)

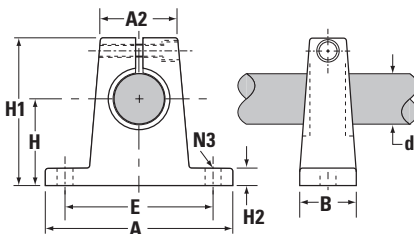

Material: Painted Malleable Iron for sizes .5 to 2 in.  
Unfinished Aluminum Alloy for sizes .25 and .375 in.

Part <sup>(2)</sup> Number	Nominal LinearRace Diameter d	H $\pm.002$	H1	H2	A	A2	B	E $\pm.010$	N3		Weight lb
									Hole	Bolt	
SB4	.250	.687	1.06	.25	1.50	.63	.50	1.125	.16	#6	.03
SB6	.375	.750	1.19	.25	1.63	.69	.56	1.250	.16	#6	.05
SB8	.500	1.000	1.63	.25	2.00	.75	.63	1.500	.19	#8	.30
SB10	.625	1.000	1.75	.31	2.50	.88	.69	1.875	.22	#10	.40
SB12	.750	1.250	2.13	.31	2.75	1.00	.75	2.000	.22	#10	.50
SB16	1.000	1.500	2.56	.38	3.25	1.38	1.00	2.500	.28	.25	1.0
SB20	1.250	1.750	3.00	.44	4.00	1.75	1.13	3.000	.34	.31	2.0
SB24	1.500	2.000	3.50	.50	4.75	2.00	1.25	3.500	.34	.31	2.6
SB32	2.000	2.500	4.50	.63	6.00	2.63	1.50	4.500	.41	3/8	4.8

### Type ASB 60 Case LinearRace Shaft End Support Blocks (Dimensions in inches)

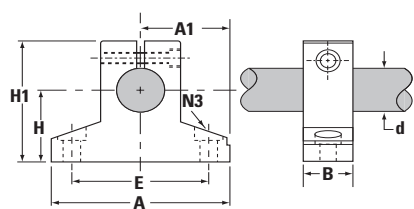

Material: Unfinished Aluminum Alloy

Part <sup>(2)</sup> Number	Nominal LinearRace Diameter d	H $\pm.001$	H1	A	A1 $\pm.001$	B	E $\pm.010$	N3		Weight lb
								Hole	Bolt	
ASB4	.250	.500	.89	1.50	.750	.50	1.12	.16	#6	.06
ASB6	.375	.562	1.00	1.62	.813	.56	1.25	.16	#6	.08
ASB8	.500	.875	1.48	2.00	1.000	.63	1.50	.19	#8	.11
ASB12	.750	1.125	1.95	2.50	1.250	.75	2.00	.22	#10	.22
ASB16	1.000	1.375	2.48	3.25	1.625	1.00	2.50	.28	1/4	.44
ASB24	1.500	2.000	3.50	4.75	2.375	1.25	3.50	.34	5/16	1.16

## Shaft Support Blocks – Type FSB

### Type FSB Flanged 60 Case® LinearRace® Shaft End Support Blocks

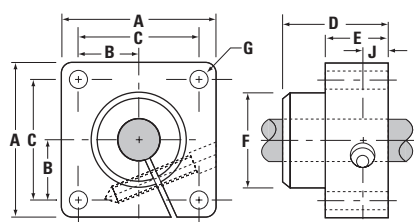

Part Number	Nominal LinearRace Diameter d	A $\pm.001$	B	C $\pm.010$	D	E	F	G		J	Weight lb
								Hole	Bolt		
FSB8	.500	1.63	.63	1.250	.88	.50	1.00	.81	#8	.25	0.3
FSB12	.750	2.38	.88	1.750	1.00	.63	1.25	.21	#10	.31	0.6
FSB16	1.000	2.75	1.06	2.125	1.25	.63	1.50	.27	1/4	.31	0.8
FSB20	1.250	3.13	1.19	2.375	1.38	.75	1.75	.27	1/4	.38	0.9

# Hardened and Ground 60 Case Precision LinearRace Shafting

## Part Number Description

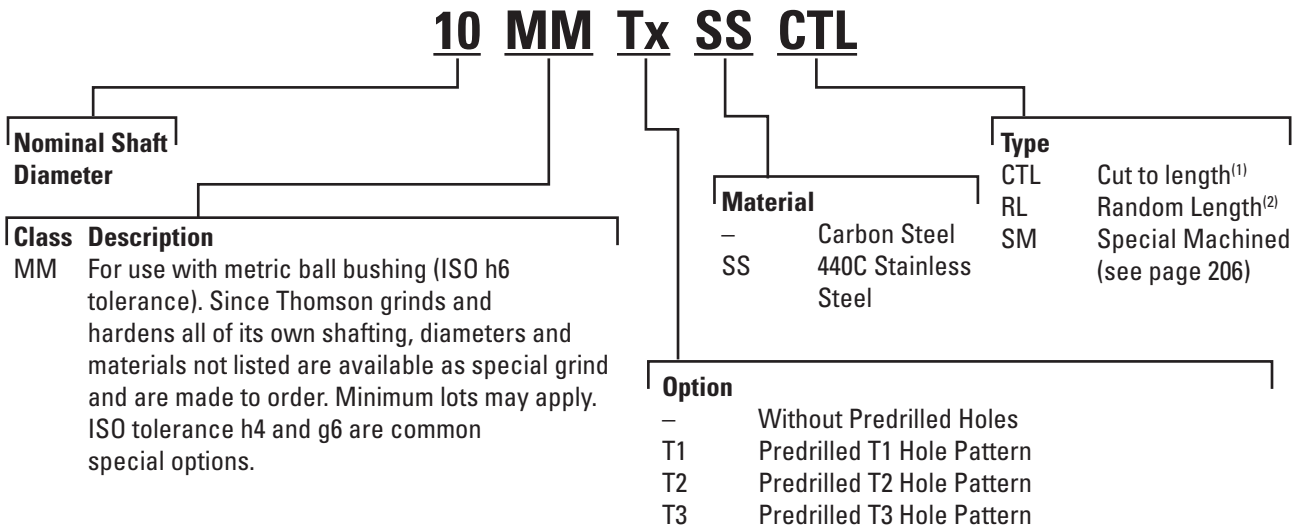

(1) CTL = Cut to length is Thomson 60 Case cut to your specified length.

(2) RL = Random length is full bar or long length shafting. It is called random length because we start with a raw bar 4" to 6" longer than the minimum usable but guarantee only the minimum visible. We mark the ends of what is out of our own tolerance. This is the result of the manufacturing process and tightly controlled roundness specifications.

Not all options are available in all sizes.

See catalog pages or contact Thomson Customer Support for combination availability.

For additional information on material options, see page 264.

## Solid Carbon Steel

Hardness: 60 ROCKWELL C Min.

Surface Finish: 8 Ra microinch Max

Roundness: .0020 mm (.000080") Class MM

Straightness: .0254 mm (.001") Per Foot Cumulative  
(.051 mm (.002") TIR)

Taper: .0025 mm (.001")

Nominal Diameter (mm)	Basic Part Number	Diameter Tolerance		Min. Usable Length		Min. Hardness Depth		Weight per m (kg)	Weight per inch (lb)
		(mm)	(inch)	(mm)	(inch)	(mm)	(inch)		
5	5 MM	5.00	.1969	1905	54	0.69	0.027	0.16	0.009
		4.99	.1965						
8	8 MM	8.00	.3150	4216	166	0.69	0.027	0.39	0.022
		7.99	.3146						
10	10 MM	10.00	.3937	4216	166	0.69	0.027	0.63	0.035
		9.99	.3932						
12	12 MM	12.00	.4724	4216	166	1.02	0.04	0.89	0.050
		11.99	.4720						
15	15 MM	15.00	.5906	4521	202	1.02	0.04	1.38	0.077
		14.99	.5902						
16	16 MM	16.00	.6299	4521	202	1.02	0.04	1.57	0.088
		15.99	.6295						
20	20 MM	20.00	.7874	4521	202	1.52	0.06	2.47	0.138
		19.99	.7869						
25	25 MM	25.00	.9843	4521	202	2.03	0.08	3.87	0.216
		24.99	.9838						
30	30 MM	30.00	1.1811	4521	202	2.03	0.08	5.57	0.311
		29.99	1.1806						
40	40 MM	40.00	1.5748	4521	202	2.03	0.08	9.90	0.553
		39.99	1.5743						
50	50 MM	50.00	1.9685	4521	202	2.54	0.1	15.46	0.864
		49.98	1.9679						
60	60 MM	60.00	2.3622	4521	202	2.54	0.1	22.19	1.240
		59.98	2.3615						
80	80 MM	80.00	3.1496	5130	202	2.54	0.1	39.55	2.210
		79.97	3.1486						



## Standard Options for Carbon Steel Shafting Pre drilled (Tx)

Hardness: 60 ROCKWELL C Min.

Surface Finish: 8 Ra microinch Max

Roundness: .0020 mm (.000080") Class MM

Straightness: .0254 mm (.001") Per Foot Cumulative  
(.051 mm [.002"] TIR)

Taper: .0025 mm (.001")

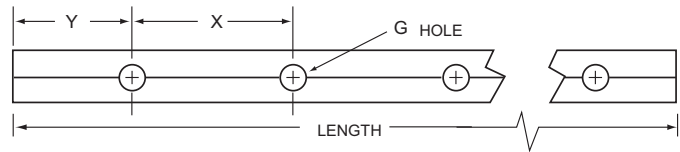

### T1 Pre drilled

Nominal Diameter (mm)	Basic Part Number	MM T1 Diameter Tolerance		X ±.40 mm (±.015") (noncumulative)		G Standard Size	Min. Usable Length		Min. Hardness Depth		Weight Per m (kg)	Weight Per in (lb)
		(mm)	(inch)	(mm)	(inch)		(mm)	(in)	(mm)	(in)		
12	12 MM T1	12.00	0.4724	75	2.953	M4	4216	166	1.02	0.04	0.89	0.050
		11.99	0.4720									
16	16 MM T1	16.00	0.6299	100	3.937	M5	4521	178	1.02	0.04	1.57	0.088
		15.99	0.6295									
20	20 MM T1	20.00	0.7874	100	3.937	M6	4521	178	1.52	0.06	2.47	0.138
		19.99	0.7869									
25	25 MM T1	25.00	0.9843	120	4.724	M8	4521	178	2.03	0.08	3.87	0.216
		24.99	0.9838									
30	30 MM T1	30.00	1.1811	150	5.906	M10	4521	178	2.03	0.08	5.57	0.311
		29.99	1.1806									
40	40 MM T1	40.00	1.5748	200	7.874	M10	4521	178	2.03	0.08	9.90	0.553
		39.99	1.5743									

### T2 Pre drilled

Nominal Diameter (mm)	Basic Part Number	MM T2 Diameter Tolerance		X ±.40 mm (±.015") (noncumulative)		G Standard Size	Min. Usable Length		Min. Hardness Depth		Weight Per m (kg)	Weight Per in (lb)
		(mm)	(inch)	(mm)	(inch)		(mm)	(in)	(mm)	(in)		
12	12 MM T2	12.00	0.4724	120	4.724	M4	4216	166	1.02	0.04	0.89	0.050
		11.99	0.4720									
16	16 MM T2	16.00	0.6299	150	5.906	M5	4521	178	1.02	0.04	1.57	0.088
		15.99	0.6295									
20	20 MM T2	20.00	0.7874	150	5.906	M6	4521	178	1.52	0.06	2.47	0.138
		19.99	0.7869									
25	25 MM T2	25.00	0.9843	200	7.874	M8	4521	178	2.03	0.08	3.87	0.216
		24.99	0.9838									
30	30 MM T2	30.00	1.1811	200	7.874	M10	4521	178	2.03	0.08	5.57	0.311
		29.99	1.1806									
40	40 MM T2	40.00	1.5748	300	11.811	M10	4521	178	2.03	0.08	9.90	0.553
		39.99	1.5743									

### T3 Pre drilled

Nominal Diameter (mm)	Basic Part Number	MM T3 Diameter Tolerance		X ±.40 mm (±.015") (noncumulative)		G Standard Size	Min. Usable Length		Min. Hardness Depth		Weight Per m (kg)	Weight Per in (lb)
		(mm)	(inch)	(mm)	(inch)		(mm)	(in)	(mm)	(in)		
12	12 MM T3	12.00	0.4724	75	2.953	M4	4216	166	1.02	0.04	0.89	0.050
		11.99	0.4720									
16	16 MM T3	16.00	0.6299	75	2.953	M5	4521	178	1.02	0.04	1.57	0.088
		15.99	0.6295									
20	20 MM T3	20.00	0.7874	75	2.953	M6	4521	178	1.52	0.06	2.47	0.138
		19.99	0.7869									
25	25 MM T3	25.00	0.9843	75	2.953	M8	4521	178	2.03	0.08	3.87	0.216
		24.99	0.9838									
30	30 MM T3	30.00	1.1811	100	3.937	M10	4521	178	2.03	0.08	5.57	0.311
		29.99	1.1806									
40	40 MM T3	40.00	1.5748	100	3.937	M10	4521	178	2.03	0.08	9.90	0.553
		39.99	1.5743									

Holes are drilled and tapped to the center of the shaft. Y = distance from end of rail to the center of first mounting hole, Y1 = Y2 unless specified.

**440C Stainless Steel**

Hardness: 50 ROCKWELL C Min.

Surface Finish: 8 Ra microinch Max

Straightness: .0254 mm (.001") Per Foot Cumulative  
(.051 mm [.002"] TIR)

Roundness: .0020 mm (.000080") Class MM

Taper: .0025 mm (.001")

Nominal Dia. (mm)	Basic Part Number	Diameter Tolerance		Min. Usable Length		Min. Hardness Depth		Weight Per m (kg)	Weight Per in (lb)
		(mm)	(inch)	(mm)	(in)	(mm)	(in)		
5	5 MM SS	5.00	0.1969	1905	54	0.69	0.027	0.16	0.009
		4.49	0.1965						
8	8 MM SS	8.00	0.3150	4521	178	0.69	0.027	0.39	0.022
		7.99	0.3146						
10	10 MM SS	10.00	.03937	4521	178	0.69	0.027	0.63	0.035
		9.99	0.3932						
12	12 MM SS	12.00	0.4724	4521	178	1.02	0.04	0.89	0.050
		11.99	0.4720						
16	16 MM SS	16.00	0.6299	4521	178	1.02	0.04	1.57	0.088
		15.99	0.6295						
20	20 MM SS	20.00	0.7874	4521	178	1.52	0.06	2.47	0.138
		19.99	0.7869						
25	25 MM SS	25.00	0.9843	4521	178	2.03	0.08	3.87	0.216
		24.99	0.9838						
30	30 MM SS	30.00	1.1811	4521	178	2.03	0.08	5.57	0.311
		29.99	1.1806						
40	40 MM SS	40.00	1.5748	4521	178	2.03	0.08	9.90	0.553
		39.99	1.5743						
50	50 MM SS	50.00	1.9685	4521	178	2.54	0.1	15.46	0.864
		49.98	1.9679						
60	60 MM SS	60.00	2.3622	4521	178	2.54	0.1	22.19	1.240
		59.98	2.3615						



# Support Rails and Assemblies for Continuously Supported Applications

## Part Number Description

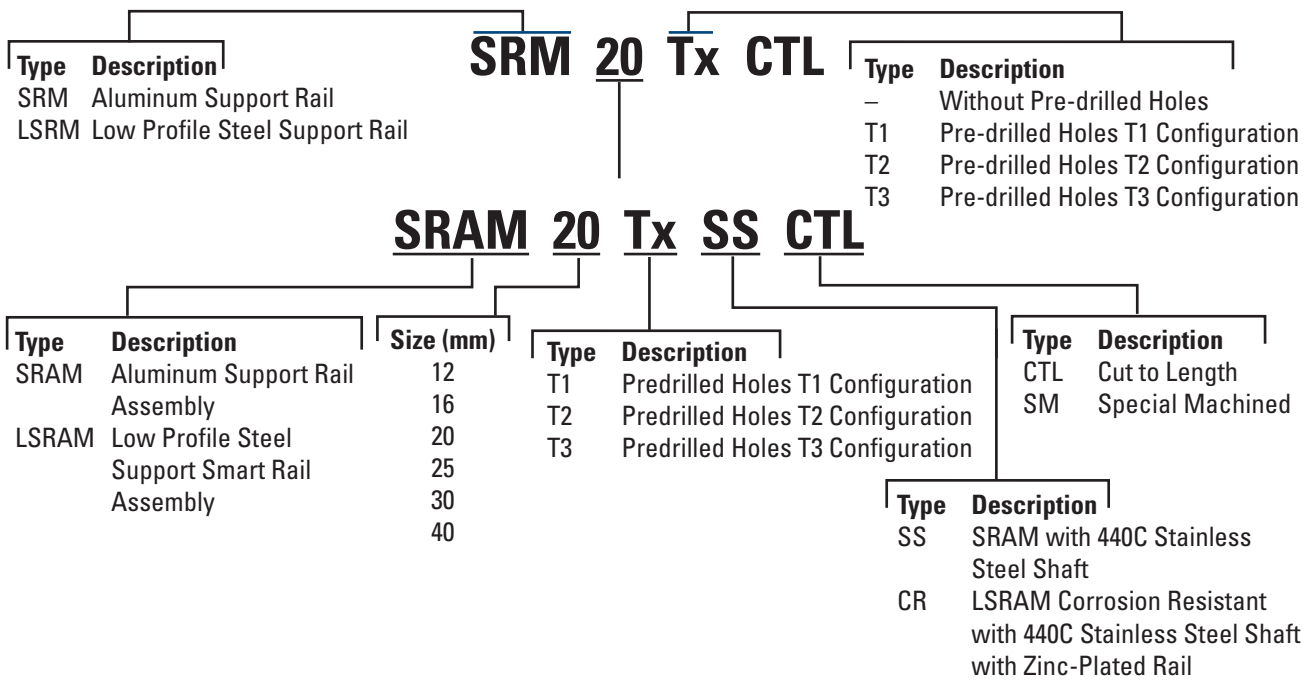

Not all options are available in all sizes.

See catalog pages or contact Thomson Customer Support for combination availability.

For additional information on material options, see page 264.

## Shaft Rail Supports Type SRM, SRMTx

### The low cost way of mounting Thomson 60 Case® shafts

Shaft supports simplify mounting of Thomson 60 Case shafts. Users of Thomson 60 Case shafting should carefully consider the use of these low-cost shaft supports. They are standard, available from stock, and simplify shaft mounting. In addition to many other benefits, they eliminate many problems encountered in designing and manufacturing shaft-supporting devices. These versatile mounts can be used horizontally or vertically, and in many different arrangements. Shaft support rails are available without predrilled holes (SRM), or predrilled (SRMTx) shaft rails to support 12 mm to 40 mm diameter shafts are available in standard 600 mm where shorter lengths are needed, rails are easily cut to length. For longer shafts, they can be mounted end to end, using shims or grout, if necessary, to compensate for slight variation within manufacturing tolerance. Thomson offers shaft support rails with predrilled holes to simplify shaft mounting.

## Low Shaft Support Rails Type LSRM, LSRMTx

### For compact designs

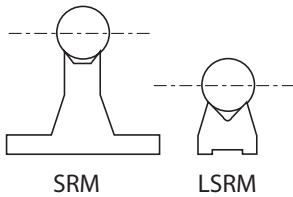

Low shaft rails allow the design of more compact linear motion systems. The height from the base to the mean shaft center ranges from 14 mm for supporting a 12 mm diameter shaft to a maximum 39 mm when supporting a 40 mm diameter shaft – 40% lower than standard support rails. Low shaft rails are made of steel to maintain optimum shaft rigidity. Either continuous or intermittent support is possible when using Thomson open-type linear ball bearings. Low shaft rails are furnished in standard 1200 mm lengths. Where shorter lengths are required, rails can easily be cut. For supporting longer shafts, rails can be mounted end-to-end without limit. Low shaft rails are available without predrilled mounting holes (LSRM) or with predrilled mounting holes (LSRMTx) to match Thomson drilled and tapped shafts (Tx).

**Note:** When using LSRMTx, the attachment bolts are from underneath, so you must have access under your machine base plate. The LSRAM assemblies highlighted below utilize attachment bolts from above. If one of the standard predrilled low shaft rails is not appropriate for your design needs, low shaft rails can be custom drilled by Thomson to your specifications. Send a print with all required dimensions, tolerances and quantities needed to our application engineering team.

## Pre-Assembled Shaft Rail Assemblies Type SRAM & LSRAM

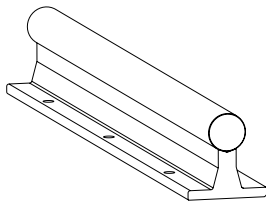

**SRAM**

Thomson 60 Case steel shafts mounted on shaft support rails are now available for instant bolt-down installation. Assemblies are supplied cut to any length with no limit on the overall length (long lengths are butt jointed together unless specified otherwise). Either solid or lightweight tubular shafting can be assembled to the standard Thomson support rails, which come with base mounting holes spaced evenly along the overall length of the assembly. The LSRAM uses a special shaft unlike the LSRMTx. The attachment bolts for the LSRAM are from the top down so you can easily mount into a machine base plate. The LSRAM bolt pattern closely matches profile rail linear guides and can easily be used as a drop-in substitute to replace linear guides (ensure you review loading requirements).



# 60 Case® LinearRace® Support Rails for Continuously Supported Applications

## Type SRM/SRMTx LinearRace Support Rails (Dimensions in mm)

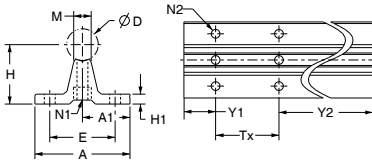

Material: Aluminum Alloy

Without Holes	With T1 Hole Spacing	With T2 Hole Spacing	With T3 Hole Spacing	D h6	H ±.02	H1	A	A1 ±.02	M	E ±.15	Bolt Hole					Weight (kg/600 mm)
											Spacing			Sizes		
											T1	T2	T3	N1	N2	
SRM12	SRM12T1	SRM12T2	SRM12T3	12	28	5	43	21.5	9	29	75	120	75	M4	4.5	0.62
SRM16	SRM16T1	SRM16T2	SRM16T3	16	30	5	48	24.0	10	33	100	150	75	M5	5.5	0.72
SRM20	SRM20T1	SRM20T2	SRM20T3	20	38	6	56	28.0	11	37	100	150	75	M6	6.6	1.02
SRM25	SRM25T1	SRM25T2	SRM25T3	25	42	6	60	30.0	14	42	120	200	75	M8	6.6	1.23
SRM30	SRM30T1	SRM30T2	SRM30T3	30	53	8	74	37.0	14	51	150	200	100	M10	8.6	1.89
SRM40	SRM40T1	SRM40T2	SRM40T3	40	60	8	78	39.0	18	55	200	300	100	M10	8.6	2.28

N1 Hole Dia. includes counterbore for socket head cap screw. Alignment and location of holes are ±.15, noncumulative. Maximum Length 600 mm. Y1=Y2 unless specified by customer.

## Type LSRM/LSRMTx LinearRace Support Rails (Dimensions in mm)

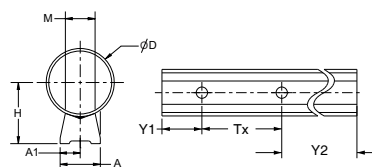

Material: Steel

Without Holes	With T1 Hole Spacing	With T2 Hole Spacing	With T3 Hole Spacing	D h6	H ±.02	A	A1 ±.02	M	E ±.15	Bolt Hole				Weight (kg/1200 mm)
										Spacing			Sizes	
										T1	T2	T3	N	
LSRM12	LSRM12T1	LSRM12T2	LSRM12T3	12	14	12	6.0	6.0	75	120	75	M4	0.68	
LSRM16	LSRM16T1	LSRM16T2	LSRM16T3	16	18	14	7.0	7.0	100	150	75	M5	0.99	
LSRM20	LSRM20T1	LSRM20T2	LSRM20T3	20	22	17	8.5	8.3	100	150	75	M6	1.45	
LSRM25	LSRM25T1	LSRM25T2	LSRM25T3	25	26	21	10.5	10.8	120	200	75	M8	2.06	
LSRM30	LSRM30T1	LSRM30T2	LSRM30T3	30	30	23	11.5	11.0	150	200	100	M10	2.39	
LSRM40	LSRM40T1	LSRM40T2	LSRM40T3	40	36	23.6	11.8	17.5	200	300	100	M12	4.05	

Maximum Length 1200 mm. Y1=Y2 unless specified by customer.

## Type SRAMTx LinearRace Shafting Support Rail Assemblies (Dimensions in mm)

Part Number			d	H ±.02	H1	A	A1 ±.02	M	E ±.15	N1	N2	T1	T2	T3	Weight (kg/m) <sup>(1)</sup>
SRAMT1 Assembly with LinearRace shafting	SRAMT2 Assembly with LinearRace shafting	SRAMT3 Assembly with LinearRace shafting													
SRAM12T1	SRAM12T2	SRAM12T3	12	28	5	43	21.5	9	29	M4	4.5	75	120	75	1.91
SRAM16T1	SRAM16T2	SRAM16T3	16	30	5	48	24	10	33	M5	5.5	100	150	75	2.75
SRAM20T1	SRAM20T2	SRAM20T3	20	38	6	56	28	11	37	M6	6.6	100	150	75	4.15
SRAM25T1	SRAM25T2	SRAM25T3	25	42	6	60	30	14	42	M8	6.6	120	200	75	5.86
SRAM30T1	SRAM30T2	SRAM30T3	30	53	8	74	37	14	51	M10	8.6	150	200	100	8.65
SRAM40T1	SRAM40T2	SRAM40T3	40	60	8	78	39	18	55	M10	8.6	200	300	100	13.6

(1) Assembly weights do not include hardware. Y1=Y2 unless specified by customer.

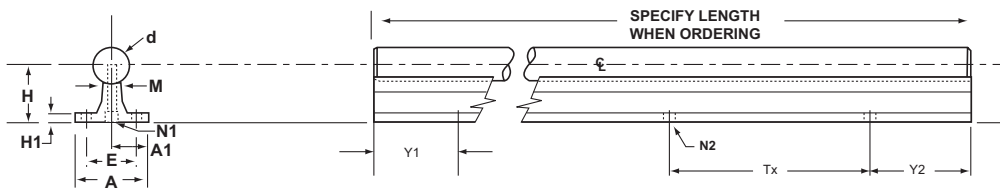

## Type LSRAM Smart Rail Assemblies (Dimensions in mm)

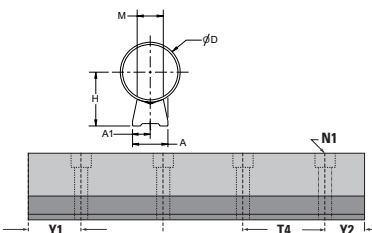

Material: Steel Alloy

Part Number <sup>(3)</sup>		LinearRace Diameter h6	H ±.02	A	A1 ±.02	M ±.15	Bolt Hole		Weight (kg/m) <sup>(4)</sup>
Smart Rail Assembly <sup>(1)</sup> Shafting	Smart Rail Assembly <sup>(2)</sup> Shafting						T4	N1	
LSRAM16	LSRAM16-CR	16	18	14	7.0	7.0	40	M3	2.56
LSRAM20	LSRAM20-CR	20	22	17	8.5	8.3	60	M4	3.93
LSRAM25	LSRAM25-CR	25	26	21	10.5	10.8	60	M5	5.97
LSRAM30	LSRAM30-CR	30	30	23	11.5	11.7	80	M6	8.12
LSRAM40	LSRAM40-CR	40	36	23.6	11.8	17.5	105	M10	14.27

(1) Consists of black oxide steel rail and high carbon steel LinearRace shafting (HRC 60 min.).  
 (2) Consists of zinc plated steel rail and 440C stainless steel LinearRace shafting (HRC 50 min.).  
 (3) Specify length of Smart Rail when ordering. For example, LSRAM20 x 1200 mm. Y dimension is equal on each end unless specified by customer.  
 (4) Assembly weights do not include hardware.  
 NOTE: LSRAMs do not use standard "PD" shafting. The shafting requires a different hole pattern and configuration.  
 NOTE: Use only with Super Smart open pillow blocks.

# Support Block for End-Supported Applications

## Part Number Description

### ASBM 16

Type	Description	Size (mm)	
ASBM	Low Profile 60 Case LinearRace End Support Block	8	25
SBM	Standard 60 Case LinearRace End Support Block	12	30
		16	40
		20	

## Shaft Support Blocks – Type SBM and ASBM

### For end support or intermittent support

Shaft support blocks are used for end or intermittent support where loads are light and deflection between supports is not a problem. Unlike shaft support rails, blocks do not permit longitudinal passage of open-type Ball Bushing® Bearings. Type SBM shaft support blocks enable clamping of shafts and eliminate the need for bolts, etc. to maintain shaft position. Shimming is suggested for high-precision applications to eliminate the effect of variations in surface of base or manufacturing tolerances between supports.



Type ASBM shaft blocks, manufactured from high-strength, extruded aluminum, provide either end or intermittent support in applications where loads are designed with a reference edge on one side of the base. This provides a surface parallel to the center of the shaft within ±.025 mm that can be used to simplify shaft alignment.

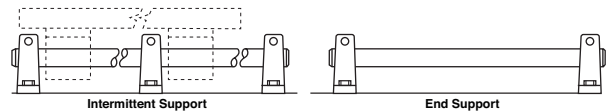

### Type SBM 60 Case LinearRace Shaft End Support Blocks (Dimensions in mm)

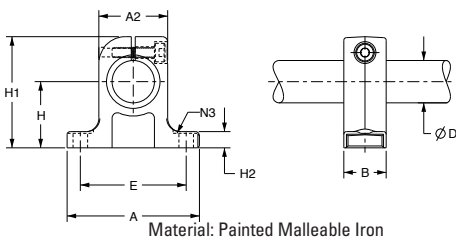

Material: Painted Malleable Iron

Part Number	d	H ±.025	H1	H2	A	A1 ±.30	B	E ±.30	N	Support Block Mass (kg)
SBM08	8	15	27	5.2	32	16	10	25	4.5	0.03
SBM12	12	20	35	5.5	40	21	12	32	5.5	0.06
SBM16	16	25	42	6.5	50	25	16	40	5.5	0.11
SBM20	20	30	50	8.0	60	30	20	45	5.5	0.21
SBM25	25	35	58	9.0	74	37	25	60	6.6	0.35
SBM30	30	40	68	10.0	84	42	28	68	9.0	0.52
SBM40	40	50	86	12.0	108	54	32	86	11.0	0.92

### Type ASBM 60 Case LinearRace Shaft End Support Blocks (Dimensions in mm)

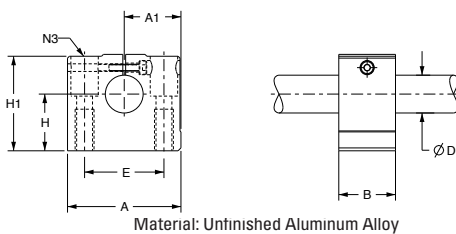

Material: Unfinished Aluminum Alloy

Part Number	d	H ±.025	H1	H2	A	A1 ±.30	B	E ±.30	N	N2	Support Block Mass (kg)
ASBM08	8	15	28	9	32	16.0	18	22	3.5	M4	0.04
ASBM12	12	20	36	13	43	21.5	20	30	5.3	M6	0.10
ASBM16	16	25	43	18	53	26.5	24	38	6.6	M8	0.15
ASBM20	20	30	51	22	60	30.0	30	42	8.4	M10	0.23
ASBM25	25	35	61	26	78	39.0	38	56	10.5	M12	0.41
ASBM30	30	40	71	26	87	43.5	40	64	10.5	M12	0.53
ASBM40	40	50	88	34	108	54.0	48	82	13.5	M16	0.99



# Thomson 60 Case® Quick Shaft

“Quick shaft” is precut and packaged stock length shafting in popular:

- Inch and metric sizes
- L tolerance class and MM tolerance class
- Materials (carbon steel, 440C stainless steel, lightweight 52100 tubular)
- Standard options (predrilled and chrome-plated plain ends)



Thomson 60 Case quick shaft can be easily stocked by authorized Thomson distributors or end users.

You may want to have a few pieces of Thomson quick shaft in your stock room if you are not sure of the exact length you may need for that potential third-shift breakdown or you perform your own special machining of various lengths and do not want to carry different cut-to-length sizes.

All Thomson quick shaft shafting are oil preserved and placed in a VCI bag for long-term storage and labeled for your convenience.

## Part Number Description

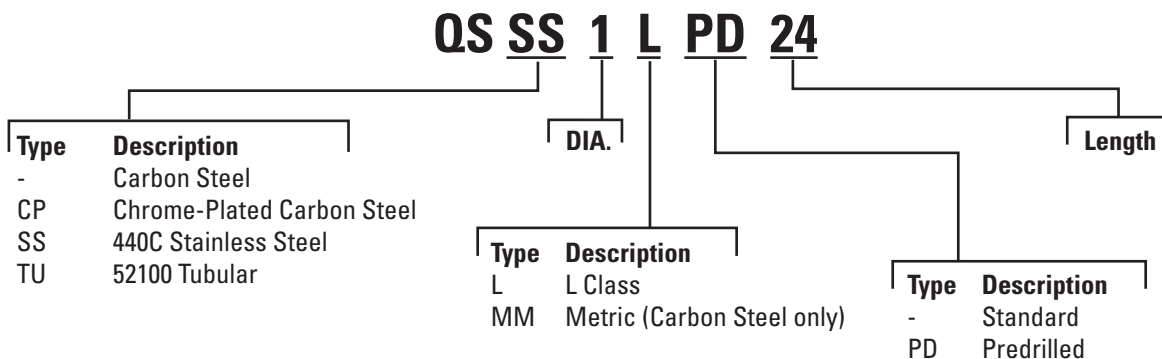

Not all options are available in all sizes.  
 See catalog pages or contact Thomson Customer Support for combination availability.  
 For additional information on material options, see page 264.

# 60 Case Quick Shaft

## Carbon Steel - Inch

Hardness: 60 ROCKWELL C Min.  
Surface Finish: 8 Ra microinch Max  
Roundness: .000080"

Straightness: .001" Per Foot Cumulative  
Taper: .0001"

Part Number	Stock Lengths (in)	Diameter Tolerance (in)	Min. Hardness Depth (in)	Weight Per Inch (lb)
QS 1/4 L	6, 9, 12, 15, 18, 24, 30, 36, 42, 48, 60	.2495	.027	.014
		.2490		
QS 3/8 L	6, 12, 18, 24, 30, 36, 48, 60	.3745	.027	.031
		.3740		
QS 1/2 L	6, 9, 12, 15, 18, 24, 30, 36, 42, 48, 54, 60	.4995	.040	.055
		.4990		
QS 5/8 L	12, 15, 18, 24, 30, 36, 42, 48, 54, 60	.6245	.040	.086
		.6240		
QS 3/4 L	12, 15, 18, 24, 30, 36, 42, 48, 60, 66, 72	.7495	.060	.125
		.7490		
QS 1 L	12, 18, 24, 30, 36, 42, 48, 60, 66, 72	.9995	.080	.222
		.9990		
QS 1 1/4 L	12, 18, 24, 30, 36, 42, 48, 54, 60, 72	1.2495	.080	.348
		1.2490		
QS 1 1/2 L	12, 18, 24, 30, 36, 42, 48, 54, 60, 66, 72	1.4994	.080	.500
		1.4989		
QS 1 3/4 L	12, 18, 24, 30, 36, 42, 48, 60, 72	1.7495	.100	.681
		1.7490		
QS 2 L	12, 18, 24, 30, 36, 42, 48, 60, 72	1.9994	.100	.890
		1.9987		

## Carbon Steel - Metric

Hardness: 60 ROCKWELL C Min.  
Surface Finish: 8 Ra microinch Max  
Roundness: .000080"

Straightness: .001" Per Foot Cumulative  
Taper: .0001"

Part Number	Stock Lengths (mm)	Diameter		Min. Hardness Depth		Weight Per m	Weight Per inch
		(mm)	(in)	(mm)	(in)	(kg)	(lb)
QS 10 MM	500, 1000	10.00	.3937	.069	.027	0.63	.035
		9.99	.3932				
QS 12 MM	250, 500, 750, 1000, 1200, 1500, 2000	12.00	.4724	1.02	.040	0.89	.05
		11.99	.4720				
QS 16 MM	250, 500, 750, 1000, 1200, 1500, 2000	16.00	.6299	1.02	.040	1.57	.088
		15.99	.6295				
QS 20 MM	250, 500, 750, 1000, 1200, 1500, 2000	20.00	.7874	1.52	.060	2.33	.13
		19.99	.7869				
QS 25 MM	500, 750, 1000, 1200, 1500, 2000	25.00	.9843	2.03	.080	3.87	.216
		24.99	.9838				
QS 30 MM	500, 750, 1000, 1500, 2000	30.00	1.1811	2.03	.080	5.57	.311
		29.99	1.1806				
QS 40 MM	500, 750, 1000, 1500, 2000	40.00	1.5748	2.03	.080	9.90	.553
		39.99	1.5743				



### 440C Stainless Steel - Inch

Hardness: 50 ROCKWELL C Min.  
 Surface Finish: 8 Ra microinch Max  
 Roundness: .000080"

Straightness: .001" Per Foot Cumulative  
 Taper: .0001"

Part Number	Stock Lengths (in)	Diameter Tolerance (in)	Min. Hardness Depth (in)	Weight Per Inch (lb)
QSSS 1/4 L	6, 12, 18, 24, 30, 36, 48, 60	.2495	.027	.014
		.2490		
QSSS 3/8 L	6, 12, 18, 24, 30, 36, 48, 60	.3745	.027	.031
		.3740		
QSSS 1/2 L	12, 18, 24, 30, 36, 42, 48, 54, 60	.4995	.040	.055
		.4990		
QSSS 5/8 L	12, 18, 24, 30, 36, 42, 48, 54, 60	.6245	.040	.086
		.6240		
QSSS 3/4 L	12, 18, 24, 30, 36, 42, 48, 54, 60, 66, 72	.7495	.060	.125
		.7490		
QSSS 1 L	18, 24, 30, 36, 42, 48, 54, 60, 66, 72	.9995	.080	.222
		.9990		
QSSS 1 1/4 L	12, 18, 24, 30, 36, 42, 48, 54, 60, 72	1.2495	.080	.348
		1.2490		
QSSS 1 1/2 L	18, 24, 30, 36, 42, 48, 54, 60, 66, 72	1.4994	.080	.500
		1.4989		

### 52100 Tubular - Inch

Hardness: 58 ROCKWELL C Min.  
 Surface Finish: 8 Ra microinch Max  
 Roundness: .000080"

Straightness: .001" Per Foot Cumulative  
 Taper: .0001"

Part Number	Stock Lengths (in)	Nominal I.D. (in)	Diameter Tolerance (in)	Min. Hardness Depth (in)	Weight Per Inch (lb/in)
QSTU 1 L	12, 18, 24, 48, 60	.599 ± 5%	.9995	.080	.158
			.9990		
QSTU 1 1/2 L	12, 18, 24, 48, 60	.890 ± 5%	1.4994	.080	.328
			1.4989		
QSTU 2 L	12, 24, 48, 60	1.250 ± 5%	1.9994	.100	.542
			1.9987		

### Carbon Steel Predrilled - Inch

Hardness: 60 ROCKWELL C Min.  
 Surface Finish: 8 Ra microinch Max  
 Roundness: .000080"  
 Straightness: .001" Per Foot Cumulative  
 Taper: .0001"  
 Y1 = Y2 Standard

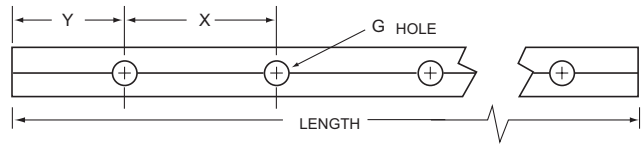

Part Number	Stock Lengths (in)	Diameter Tolerance (in)	X (in)	G Thread Size	Min. Hardness Depth (in)	Weight Per Inch (lb)
QS 1/2 L PD	12, 18, 24, 30, 36, 42, 48, 54, 60, 72	.4995	4	#6-32	.040	.055
		.4990				
QS 5/8 L PD	12, 18, 24, 30, 36, 42, 48, 54, 60, 72	.6245	4	#8-32	.040	.086
		.6240				
QS 3/4 L PD	12, 18, 24, 30, 36, 42, 48, 54, 60, 72	.7490	6	#10-32	.060	.125
		.7485				
QS 1 L PD	18, 24, 30, 36, 42, 48, 54, 60, 72	.9995 .9990	6	1/4-20	.080	.222
QS 1 1/4 L PD	18, 24, 30, 36, 42, 48, 54, 60, 72	1.2490	6	5/16-18	.080	.348
		1.2485				
QS 1 1/2 L PD	18, 24, 30, 36, 42, 48, 54, 60, 72	1.4994 1.4989	8	3/8-16	.080	.500

### 440C Stainless Steel Predrilled - Inch

Hardness: 50 ROCKWELL C Min.  
 Surface Finish: 8 Ra microinch Max  
 Roundness: .000080"

Straightness: .001" Per Foot Cumulative  
 Taper: .0001"  
 Y1 = Y2 Standard

Part Number	Stock Lengths (in)	Diameter Tolerance (in)	X (in)	G Thread Size	Min. Hardness Depth (in)	Weight Per Inch (lb)
QSSS 1/2 L PD	24, 30, 36, 42, 48, 60, 72	.4995	4	#6-32	.040	.055
		.4990				
QSSS 5/8 L PD	24, 30, 36, 42, 48, 54, 60, 72	.6245	4	#8-32	.040	.086
		.6240				
QSSS 3/4 L PD	24, 30, 36, 42, 48, 54, 60, 72	.7490	6	#10-32	.060	.125
		.7485				
QSSS 1 L PD	18, 24, 30, 36, 42, 48, 54, 60, 72	.9995 .9990	6	1/4-20	.080	.222
QSSS 1 1/4 L PD	18, 24, 30, 36, 42, 48, 54, 60, 72	1.2490	6	5/16-18	.080	.348
		1.2485				
QSSS 1 1/2 L PD	18, 24, 30, 36, 42, 48, 54, 60, 72	1.4994 1.4989	8	3/8-16	.080	.500

### Chrome Plated Plain Ends - Inch

Hardness: 60 ROCKWELL C Min.  
 Surface Finish: 8 Ra microinch Max  
 Roundness: .000080"

Straightness: .001" Per Foot Cumulative  
 Taper: .0001"

Part Number	Stock Lengths (in)	Diameter Tolerance (in)	Min. Hardness Depth (in)	Weight Per Inch (lb)
QSCP 1/2 L	6, 12, 18, 24, 30, 36, 42, 48, 60	.4995	.040	.055
		.4990		
QSCP 5/8 L	12, 18, 24, 30, 36, 42, 48, 54, 60	.6245	.040	.086
		.6240		
QSCP 3/4 L	12, 18, 24, 30, 36, 42, 48, 54, 60	.7595	.060	.125
		.7490		
QSCP 1 L	12, 18, 24, 30, 36, 42, 48, 54, 60, 72	.9995 .9990	.080	.222
QSCP 1 1/4 L	18, 24, 30, 36, 42, 48, 54, 60, 66, 72	1.2495	.080	.348
		1.2490		
QSCP 1 1/2 L	18, 24, 30, 36, 42, 48, 54, 60, 66, 72	1.4994	.080	.500
		1.4989		



## Special Machining

For more than 75 years, Thomson has been providing custom special machining on 60 Case® linear shafting. Our skilled machinists can perform a wide variety of special machining operations on the ends or along the length of the 60 Case shaft to provide exactly the part needed for your application.

Standard 60 Case shafting, which is available from stock, can be cut with special length tolerances. 60 Case shafting may also be drilled with a variety of radial holes and tapped if needed. Shafts can be supplied with flats, keyways and reduced diameters. Shafts can also be plated.

There is an extra charge for all special machining operations. For specific prices, send your drawing or technical description to Thomson or utilize a copy of the request for quotation and templates found on pages 210 - 227.

### Special Length Tolerances

Standard length tolerance is for  $\pm 1/32''$  for shafts less than 2" diameter and  $\pm 1/16''$  for 2" diameter and larger. Special length tolerances of  $\pm .010''$ ,  $\pm .005''$  and  $\pm .002''$  can be achieved on shafts up to 4" in diameter.

### Special Straightness Tolerances

Standard straightness is .001" per foot, cumulative (.002" TIR). Special straightness tolerance is .0005" per foot, cumulative (.001" TIR), for all diameters.

### Special Chamfer

$1/32'' \times 45^\circ$  for diameters less than 1" and  $1/16'' \times 45^\circ$  for diameters 1" and larger. Special chamfers at any angle can be supplied for an additional charge.

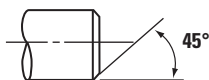

### Machining Shaft Ends

For all machining requirements with turned ends, Thomson will anneal the end. The annealing process may cause approximately  $1/4''$  to  $1/2''$  of heat travel from machined area (depending on major shaft O.D.). Hardness of major shaft diameter near the machined area will be below the Rockwell hardness for the material. If annealing effects are objectionable, alternate machining processes can be used which prevent major diameter softening. Contact Thomson Customer Support for special options. See relevant sections following.

### Threaded Shaft Diameter

Standard threads are either Unified National Coarse

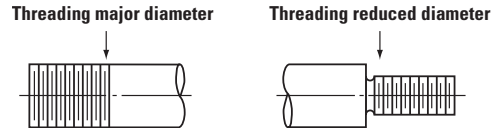

or Unified National Fine, Class 2-A fit. Shafts will be annealed and soft around the circumference of threaded areas within the case.

### Reduced Shaft Diameter

Standard diameter tolerance on turned down diameters



is  $\pm .001''$ . Special tolerance of  $\pm .0001''$  is available. Runout is within .001" total indicator reading. Shafts are annealed and soft in turned down sections within case. Two-step shaft diameter reduction is also available.

### Radial Holes Drilled and Tapped to Center of Shaft

U.N.C. or U.N.F. Class 2-B thread. Tolerances for hole alignment and location are  $\pm 1/64''$ ,  $\pm .010''$  and  $\pm .005''$ .

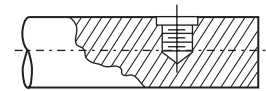

### Radial Holes Drilled and Tapped thru Shaft

U.N.C. or U.N.F. Class 2-B thread. Alignment and location tolerance  $\pm .010''$  shaft annealed and soft around circumference in hole area.

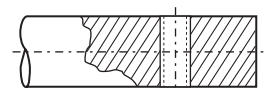

### Radial Holes Drilled through Shaft

Alignment and location tolerance  $\pm .010''$ .

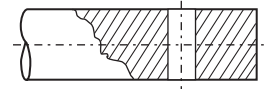

**For requests for quotation and ordering custom machined 60 Case LinearRace® shafting, see the convenient templates on pages 210 - 227.**

### Radial Holes Drilled and Reamed through Shafts

Alignment and location tolerance  $\pm .010"$ . Hole diameter tolerance  $\pm .001"$ . Shaft annealed and soft around circumference in hole area.

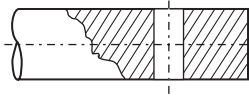

### Radial Holes Drilled through Shaft and Counterbored for Cap Screw

Alignment and location tolerance  $\pm .010"$ . Tolerance for body diameter and head diameter for American Std. cap screw is  $+ 1/32"$ . Shaft remains hard in hole area (not annealed).

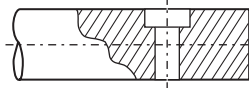

### Radial Hole Location Tolerance

Unless specified standard location tolerance between holes is  $\pm 1/64"$ , optional  $\pm .010"$  capability exists for all through hole  $\pm .005"$  for hole to center.

### Coaxial Holes Drilled and Tapped in Center of End of Shaft

U.N.C. or U.N.F. Class 2-B thread. Concentricity  $\pm .005"$ . Certain diameters and materials will be annealed and remain soft around the circumference. Note: Holes may also be located on a "bolt" circle. Location tolerance is  $.010"$ .



### Retaining Ring Groove

Location tolerances between grooves  $\pm 1/64"$  or  $\pm .005"$ . Tolerance of  $\pm .005"$  for maximum ring groove spacing is  $96"$ .



### Joining Shafts to Obtain Longer Lengths

Threaded and ground joints for  $3/4"$  through  $4"$  and 20mm thru 80 mm diameter shaft for lengths up to 20 feet. Dowled joints with concentricity  $\pm .010"$  for  $1/2"$  thru  $4"$  and 12 mm thru 80 mm diameter shaft. The feasibility of butted joints should be considered as possibly the most economical solution before considering either of the previous alternatives.

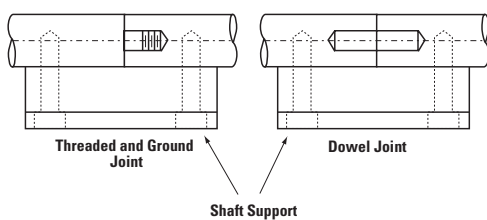

### Butted Joints

Ends machined square, no chamfer. Available for all nominal shaft diameters.

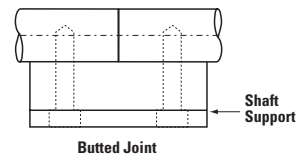

### Flats

Flats are available. Flats extending over large portion or entire length of shaft are not available. Cutting into hardened layer would cause considerable warping and subsequent straightening cost is prohibitive.

### One Flat on a Shaft

Location tolerance  $\pm .015"$ .



### Multiple Flats on a Shaft

Alignment and location tolerance  $\pm .005"$ .

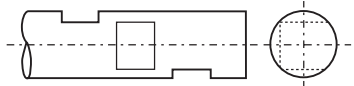

### Drilled Spot for Set Screws

Location tolerance  $\pm 1/64"$ . Capability exists for  $\pm .002"$ . Drill sizes  $1/8"$  thru  $3/4"$ .

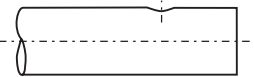

### Keyways

Keyways may be square, flat or American Standard Woodruff. Available for nominal shaft diameters from  $1/2"$  through  $4"$ .

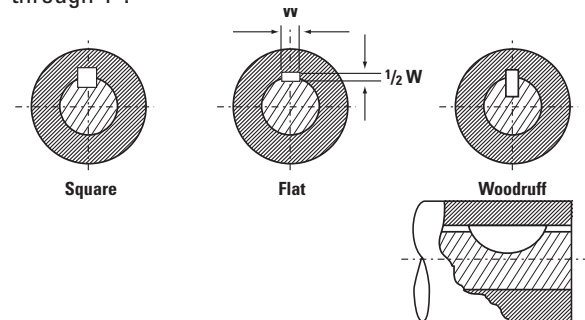

For requests for quotation and ordering custom machined 60 Case LinearRace shafting, see the convenient templates on pages 210 - 227.



## Example of Our Popular Plating Options

### Chrome Plating

The Thomson standard chrome option is pure chrome with a thickness of .00005" - .0001". (Process per AMS 2460, Class 1 (Corrosion Protective Plating), Type II (Satin finish), but with no nickel underlayer.) Other plating options are available for quote, including but not limited to Thin Dense Chrome plating per MIL-S-13165 and MIL-R-81841.

As a result of the plating process and the need to hold parts during plating, coaxial holes may be added as follows:

Up to 1 1/4" diameter shaft any length over 72".

Over 1 1/4" to 2" diameter shaft any length over 48".

Over 2" diameter shaft all lengths.

**Note:** Our chrome plated with plain ends (CPPE) do not have coaxial holes in any length, but the chamfered edges are not plated.

### Black Oxide

The benefits of black oxide is corrosion resistance and black color. The Thomson standard black oxide option meets MIL-DTL-13924D Class 1.

### ARMOLOY™

The benefits of Armoloy plating are a 78 RC surface finish, reduction of wear and friction in moving parts, and absolute adhesion to base metal (no chipping, cracking, flaking or peeling will occur). The Armoloy thickness is .0001". Final plated shaft is within specified tolerance class.

As a result of the plating process and the need to hold parts during plating, coaxial holes may be added as follows:

Up to 1 1/4" diameter shaft any length over 66".

Over 1 1/4" all lengths.

Military and industrial specifications satisfied with Armoloy plating are AMS-2438, AMS QQ-C-320 and AMS-2406.

Each supplier used for plating has different capabilities to hold the parts, so requirements for coaxial holes may change over time. These should be used as a rule of thumb with an understanding that longer lengths may have coaxial holes. These holes allow the plater to hold the shaft during the plating process. When a coaxial hole is not used, it means special tooling is available or the ability exists to pinch the part. If coaxial holes are a problem, please contact us and we can work with our supplier to determine what options exist.

# Special Machining Quoting

Thomson will be happy to quote any of your special machining needs. In order for us to properly quote the product, we will require an original product drawing or technical description to be sent to our Application Engineering support team at [thomson@regalrexnord.com](mailto:thomson@regalrexnord.com) (email) or 1-540-639-4162 (fax). Our Application Engineering team will contact you if they have any questions, require more information, or a better drawing or sketch. This drawing is important to us to ensure we quote exactly what is required at time of quotation instead of when you place your order. Upon ordering, it is important that you reference the quotation number listed at the top right of the quote and have reviewed the entire quotation, including all the notes associated and exceptions to the line item you are ordering. Quantity quoted and price listed is based on one time manufacturing lot quantity not blanket order unless otherwise stated. Thomson reserves the right to requote if quantity ordered is less than quoted quantity. Upon receipt of order, Thomson assumes you have read and understand the quotation and Thomson will assume no responsibility of exceptions on quotation and failure by customer to read.

Our standard quotations are in the format shown below.

**THOMSON™**

203A West Rock Road  
Radford, VA 24141  
United States

**QUOTATION**

Quote No : 196522 - 1  
Page : 1 of 1  
Date : 01-JAN-2016  
Customer No : 37721  
Expiration Date : 31-DEC-2016

**Internal Sales Contact:**  
First and Last Name  
FirstName.LastName@thomsonlinear.com  
Tel: 540-633-3549  
Fax: 540-639-4162

**Customer Information**

Contact Info: CONTACT PERSON  
PHONE  
CUSTOMER NAME  
CUSTOMER ADDRESS  
ANYWHERE, VA, 55555

Line	Product	Qty	Units	UNIT Net Price (USD)
10.000	1 L SM 1 L SM X 24.000IN Reference Item: 60_CASE * Shaft diameter may be out of tolerance along the length of the axial hole(s).	16	EA	67.79

**Line Item Information**

**Estimated Lead Time**

Typical Lead Time ARO (Subject to availability): 5 DAYS  
Customer Part # / Drawing #, Rev #: \*PER TEMPLATE

**Length**

Overall Length: 24.000

**Special Machining Details**

Shaft Material: CS  
Axial Holes - Total Depth (in): 2.000

**Material**

**Customer Drawing Number**

**Noted Item Quoted and Possible Exceptions**

**Quote and General Terms and Conditions**

QUOTATION NUMBER MUST APPEAR ON ORDER TO INSURE PROPER BILLING. Prices quoted are considered firm for 30 days. The Buyer and Seller agree to be bound by the terms and conditions of sale referenced in the next sentence in connection with the sale of the Goods. These terms and conditions are located at [http://www.thomsonlinear.com/terms\\_conditions](http://www.thomsonlinear.com/terms_conditions). These terms and conditions are subject to change and the Buyer is advised to review Sellers website from time to time when it places a new order for Goods.

**Quotation Number and Version Number**

**Quote Date**

**Validity Period of Quote**

**Thomson Associate Name and Contact Data**

**Unit Price**



# Request for Quotation

Custom Machined Thomson 60 Case® LinearRace® Shafting

Customer: \_\_\_\_\_

Address: \_\_\_\_\_

City: \_\_\_\_\_ State: \_\_\_\_\_ Zip: \_\_\_\_\_

Contact Name: \_\_\_\_\_

Phone: \_\_\_\_\_ Fax: \_\_\_\_\_

E-mail: \_\_\_\_\_

Template Number	Quantity
_____	_____
_____	_____
_____	_____
_____	_____
_____	_____

1. Send a copy of your drawing or sketch. If you do not have one, select the Thomson 60 Case LinearRace shaft template that best matches your requirements.

- A. Fill in all available data with tolerances in either inch or metric units.
- B. If a feature is not on the template that you are using, add it, and the applicable dimensions.
- C. If a feature is not required but is on the template, draw a line through the feature, and mark the dimension block with a line or N/A.
- D. Make any additional notes to the template to aid in quoting and manufacturing.

2. Fax this information with the template drawing to: Quotation Department at 1-540-639-4162.

For any questions or help in determining the best solution to your Thomson 60 Case LinearRace shafting requirements, please contact Application Engineering at:

Phone: 1-540-633-3549

E-mail: [thomson@regalrexnord.com](mailto:thomson@regalrexnord.com)

<p style="text-align: center;">STD. MACHINED CHAMFER UNLESS NOTED IN ANGLE 'C' (TYP.)</p> <p style="text-align: center;">D</p> <p style="text-align: center;">B (TYP)</p> <p style="text-align: center;">A</p>	<p>LENGTH 'A':</p> <p>DIAMETER 'D':</p> <p>CLASS:</p> <p>ANGLE 'C':</p> <p>CHAMFER 'B':</p>	<p>DEFAULT PRINT TOL: (INCH) FRACTIONS: ± 1/32" -H= ±.015" -HH= ±.010" -HHH= ±.005" ANGLES: ± 1/2°</p> <p>DEFAULT PRINT TOL: (METRIC) FRACTIONS: ± 1mm -H= ±.25mm -HH= ±.13mm ANGLES: ± 1/2°</p>	<p><b>THOMSON</b> Linear Motion. Optimized.<sup>™</sup></p> <p>TITLE: <b>MACHINED TO LENGTH 60 CASE TEMPLATE 1</b></p> <p>MATERIAL: (OTHER MATERIALS AVAILABLE UPON REQUEST)  <input type="checkbox"/> 1566    <input type="checkbox"/> 440C    <input type="checkbox"/> 52100  <input type="checkbox"/> TUBING  <input type="checkbox"/> OTHER: _____</p> <p>PLATING TYPE: _____ APPROVAL _____ DATE _____          DRAWN BY _____ DATE _____</p> <p>DO NOT SCALE DRAWING</p>
<p>CUSTOMER AUTHORIZATION: _____</p>			

FAX A COPY OF THIS FORM TO QUOTATION DEPARTMENT, THOMSON 1-540-639-4162



1	2	3	4
A	B	C	D
E	F		
<p>STD. MACHINED CHAMFERS UNLESS NOTED IN ANGLE 'H' (TYP) F</p>			
<p>LENGTH 'A':</p> <p>DIAMETER 'D':</p> <p>CLASS:</p> <p>THREAD 'C':</p> <p>MIN. DEPTH 'E':</p> <p>THREAD 'F':</p> <p>MIN. DEPTH 'G':</p> <p>ANGLE 'H':</p> <p>CHAMFER 'B':</p>			
<p>DEFAULT PRINT TOL: (INCH)</p> <p>FRACTIONS: <math>\pm 1/32</math>"</p> <p>.R= <math>\pm .015</math>"</p> <p>.RR= <math>\pm .010</math>"</p> <p>.RRR= <math>\pm .005</math>"</p> <p>ANGLES: <math>\pm 1/2^\circ</math></p>		<p>DEFAULT PRINT TOL: (METRIC)</p> <p>FRACTIONS: <math>\pm 1mm</math></p> <p>.R= <math>\pm .25mm</math></p> <p>.RR= <math>\pm .13mm</math></p> <p>ANGLES: <math>\pm 1/2^\circ</math></p>	
<p>CUSTOMER AUTHORIZATION: _____</p>			
<p>MATERIAL: (OTHER MATERIALS AVAILABLE UPON REQUEST)</p> <p><input type="checkbox"/> 1566 <input type="checkbox"/> 440C <input type="checkbox"/> 52100 TUBING</p> <p><input type="checkbox"/> OTHER: _____</p>		<p>APPROVAL DATE</p> <p>DRAWN BY DATE</p>	
<p>PLATING TYPE: _____</p>		<p>DO NOT SCALE DRAWING</p>	
<p><b>THOMSON</b> Linear Motion. Optimized.<sup>™</sup></p> <p><b>CO-AXIAL DRILL and TAP</b></p> <p><b>60 CASE TEMPLATE 2</b></p> <p>DRAWG NO. _____</p>			
A	B	C	D
E	F		

FAX A COPY OF THIS FORM TO QUOTATION DEPARTMENT, THOMSON 1-540-639-4162

A	B	C	D
E	F		
1	2	3	4
LENGTH 'A':	DIAMETER 'D':	CLASS:	HOLE PATTERN
THREAD 'E':	ANGLE 'C':	CHAMFER 'B':	LENGTH 'Y1':
			LENGTH 'Y2':
			No. of Holes for 'X':
DEFAULT PRINT TOL: (INCH) FRACTIONS: $\pm 1/32"$ .R= $\pm .015"$ .XR= $\pm .010"$ .RR= $\pm .005"$ ANGLES: $\pm 1/2^\circ$	DEFAULT PRINT TOL: (METRIC) FRACTIONS: $\pm 1mm$ .R= $\pm .25mm$ .XR= $\pm .13mm$ ANGLES: $\pm 1/2^\circ$	MATERIAL: (OTHER MATERIALS AVAILABLE UPON REQUEST) <input type="checkbox"/> 1566 <input type="checkbox"/> 440C <input type="checkbox"/> 52100 TUBING <input type="checkbox"/> OTHER: _____	
CUSTOMER AUTHORIZATION: _____		PLATING TYPE: _____ APPROVAL _____ DATE _____ DRAWN BY _____ DATE _____ DO NOT SCALE DRAWING	
TITLE: <b>RADIAL DRILL &amp; TAP 60 CASE TEMPLATE 3</b>		DRAWING NO. _____	
A	B	C	D
E	F	RADIAL DRILL & TAP 60 CASE TEMPLATE 3	

FAX A COPY OF THIS FORM TO QUOTATION DEPARTMENT, THOMSON 1-540-639-4162



1	2	3	4																		
A	B	C	D																		
E	F																				
<table border="1" style="width: 100%; border-collapse: collapse;"> <tr> <td style="width: 50%;">LENGTH 'A':</td> <td style="width: 50%;"></td> </tr> <tr> <td>DIAMETER 'D':</td> <td></td> </tr> <tr> <td>CLASS:</td> <td></td> </tr> <tr> <td>DIAMETER 'C':</td> <td></td> </tr> <tr> <td>MIN. DEPTH 'E':</td> <td></td> </tr> <tr> <td>DIAMETER 'F':</td> <td></td> </tr> <tr> <td>MIN. DEPTH 'G':</td> <td></td> </tr> <tr> <td>ANGLE 'H':</td> <td></td> </tr> <tr> <td>CHAMFER 'B':</td> <td></td> </tr> </table>				LENGTH 'A':		DIAMETER 'D':		CLASS:		DIAMETER 'C':		MIN. DEPTH 'E':		DIAMETER 'F':		MIN. DEPTH 'G':		ANGLE 'H':		CHAMFER 'B':	
LENGTH 'A':																					
DIAMETER 'D':																					
CLASS:																					
DIAMETER 'C':																					
MIN. DEPTH 'E':																					
DIAMETER 'F':																					
MIN. DEPTH 'G':																					
ANGLE 'H':																					
CHAMFER 'B':																					
<table border="1" style="width: 100%; border-collapse: collapse;"> <tr> <td style="width: 33%;">           DEFAULT PRINT TOL: (INCH)            FRACTIONS: ± 1/32"            .X= ±.015"            .XX= ±.010"            .XXX= ±.005"            ANGLES: ± 1/2°         </td> <td style="width: 33%;">           DEFAULT PRINT TOL: (METRIC)            FRACTIONS: ± 1mm            .X= ±.25mm            .XX= ±.13mm            ANGLES: ± 1/2°         </td> <td style="width: 34%;">           MATERIAL: (OTHER MATERIALS AVAILABLE UPON REQUEST)  <input type="checkbox"/> 1566   <input type="checkbox"/> 440C   <input type="checkbox"/> 52100 TUBING  <input type="checkbox"/> OTHER: _____         </td> </tr> <tr> <td colspan="2">           CUSTOMER AUTHORIZATION: _____         </td> <td>           PLATING TYPE: _____            APPROVAL DATE: _____            DRAWN BY DATE: _____         </td> </tr> <tr> <td colspan="2"></td> <td style="text-align: center;"> <b>DO NOT SCALE DRAWING</b> </td> </tr> </table>				DEFAULT PRINT TOL: (INCH) FRACTIONS: ± 1/32" .X= ±.015" .XX= ±.010" .XXX= ±.005" ANGLES: ± 1/2°	DEFAULT PRINT TOL: (METRIC) FRACTIONS: ± 1mm .X= ±.25mm .XX= ±.13mm ANGLES: ± 1/2°	MATERIAL: (OTHER MATERIALS AVAILABLE UPON REQUEST) <input type="checkbox"/> 1566 <input type="checkbox"/> 440C <input type="checkbox"/> 52100 TUBING <input type="checkbox"/> OTHER: _____	CUSTOMER AUTHORIZATION: _____		PLATING TYPE: _____ APPROVAL DATE: _____ DRAWN BY DATE: _____			<b>DO NOT SCALE DRAWING</b>									
DEFAULT PRINT TOL: (INCH) FRACTIONS: ± 1/32" .X= ±.015" .XX= ±.010" .XXX= ±.005" ANGLES: ± 1/2°	DEFAULT PRINT TOL: (METRIC) FRACTIONS: ± 1mm .X= ±.25mm .XX= ±.13mm ANGLES: ± 1/2°	MATERIAL: (OTHER MATERIALS AVAILABLE UPON REQUEST) <input type="checkbox"/> 1566 <input type="checkbox"/> 440C <input type="checkbox"/> 52100 TUBING <input type="checkbox"/> OTHER: _____																			
CUSTOMER AUTHORIZATION: _____		PLATING TYPE: _____ APPROVAL DATE: _____ DRAWN BY DATE: _____																			
		<b>DO NOT SCALE DRAWING</b>																			
<table border="1" style="width: 100%; border-collapse: collapse;"> <tr> <td colspan="2" style="text-align: center;"> <b>THOMSON</b>  <i>Linear Motion. Optimized.</i> </td> </tr> <tr> <td colspan="2" style="text-align: center;"> <b>CO-AXIAL DRILLED HOLES</b>  <b>60 CASE TEMPLATE 4</b> </td> </tr> <tr> <td colspan="2" style="text-align: center;">           DRAWG NO. _____         </td> </tr> </table>				<b>THOMSON</b> <i>Linear Motion. Optimized.</i>		<b>CO-AXIAL DRILLED HOLES</b> <b>60 CASE TEMPLATE 4</b>		DRAWG NO. _____													
<b>THOMSON</b> <i>Linear Motion. Optimized.</i>																					
<b>CO-AXIAL DRILLED HOLES</b> <b>60 CASE TEMPLATE 4</b>																					
DRAWG NO. _____																					
1	2	3	4																		
A	B	C	D																		
E	F																				

FAX A COPY OF THIS FORM TO QUOTATION DEPARTMENT, THOMSON 1-540-639-4162

1	2	3	4	F	E	D	C	B	A												
<table border="1" style="width:100%; border-collapse: collapse;"> <tr> <td style="width:33%;">LENGTH 'A':</td> <td style="width:33%;">DIAMETER 'D':</td> <td style="width:33%;">CLASS</td> </tr> <tr> <td>DIAMETER 'C':</td> <td>LENGTH 'Y':</td> <td>WIDTH 'E':</td> </tr> <tr> <td>ANGLE 'F':</td> <td>CHAMFER 'B':</td> <td></td> </tr> </table>										LENGTH 'A':	DIAMETER 'D':	CLASS	DIAMETER 'C':	LENGTH 'Y':	WIDTH 'E':	ANGLE 'F':	CHAMFER 'B':				
LENGTH 'A':	DIAMETER 'D':	CLASS																			
DIAMETER 'C':	LENGTH 'Y':	WIDTH 'E':																			
ANGLE 'F':	CHAMFER 'B':																				
<table border="1" style="width:100%; border-collapse: collapse;"> <tr> <td style="width:33%;">                 DEFAULT PRINT TOL: (INCH)                  FRACTIONS: ± 1/32"                  .R= ±.015"                  .XX= ±.010"                  .XXX= ±.005"                  ANGLES: ± 1/2°             </td> <td style="width:33%;">                 DEFAULT PRINT TOL: (METRIC)                  FRACTIONS: ± 1mm                  .R= ±.25mm                  .XX= ±.13mm                  ANGLES: ± 1/2°             </td> <td style="width:33%;">                 MATERIAL: (OTHER MATERIALS AVAILABLE UPON REQUEST)  <input type="checkbox"/> 1566    <input type="checkbox"/> 440C    <input type="checkbox"/> 52100 TUBING  <input type="checkbox"/> OTHER: _____             </td> </tr> <tr> <td colspan="3">                 CUSTOMER AUTHORIZATION: _____             </td> </tr> <tr> <td colspan="3">                 PLATING TYPE: _____             </td> </tr> <tr> <td colspan="3">                 DO NOT SCALE DRAWING             </td> </tr> </table>										DEFAULT PRINT TOL: (INCH) FRACTIONS: ± 1/32" .R= ±.015" .XX= ±.010" .XXX= ±.005" ANGLES: ± 1/2°	DEFAULT PRINT TOL: (METRIC) FRACTIONS: ± 1mm .R= ±.25mm .XX= ±.13mm ANGLES: ± 1/2°	MATERIAL: (OTHER MATERIALS AVAILABLE UPON REQUEST) <input type="checkbox"/> 1566 <input type="checkbox"/> 440C <input type="checkbox"/> 52100 TUBING <input type="checkbox"/> OTHER: _____	CUSTOMER AUTHORIZATION: _____			PLATING TYPE: _____			DO NOT SCALE DRAWING		
DEFAULT PRINT TOL: (INCH) FRACTIONS: ± 1/32" .R= ±.015" .XX= ±.010" .XXX= ±.005" ANGLES: ± 1/2°	DEFAULT PRINT TOL: (METRIC) FRACTIONS: ± 1mm .R= ±.25mm .XX= ±.13mm ANGLES: ± 1/2°	MATERIAL: (OTHER MATERIALS AVAILABLE UPON REQUEST) <input type="checkbox"/> 1566 <input type="checkbox"/> 440C <input type="checkbox"/> 52100 TUBING <input type="checkbox"/> OTHER: _____																			
CUSTOMER AUTHORIZATION: _____																					
PLATING TYPE: _____																					
DO NOT SCALE DRAWING																					
<table border="1" style="width:100%; border-collapse: collapse;"> <tr> <td style="width:33%; text-align:center;"> </td> <td style="width:33%; text-align:center;">                 Linear Motion. Optimized.™             </td> <td style="width:33%; text-align:center;">                 TITLE:                  SNAP RING GROOVE                  60 CASE TEMPLATE 5             </td> </tr> </table>											Linear Motion. Optimized.™	TITLE: SNAP RING GROOVE 60 CASE TEMPLATE 5									
	Linear Motion. Optimized.™	TITLE: SNAP RING GROOVE 60 CASE TEMPLATE 5																			
1	2	3	4	F	E	D	C	B	A												

FAX A COPY OF THIS FORM TO QUOTATION DEPARTMENT, THOMSON 1-540-639-4162



A	B	C	D	E	F
<p>STD. MACHINED CHAMFER UNLESS NOTED IN ANGLE 'H'</p> <p>.015 RAD. TYP.</p>					
<p>LENGTH 'A':</p> <p>DIAMETER 'D':</p> <p>CLASS:</p> <p>DIAMETER 'C':</p> <p>LENGTH 'G':</p> <p>DIAMETER 'E':</p> <p>LENGTH 'F':</p> <p>ANGLE 'H':</p> <p>CHAMFER 'B':</p>					
<p>DEFAULT PRINT TOL: (INCH)</p> <p>FRACTIONS: <math>\pm 1/32</math>"</p> <p>.X= <math>\pm .015</math>"</p> <p>.XX= <math>\pm .010</math>"</p> <p>.XXX= <math>\pm .005</math>"</p> <p>ANGLES: <math>\pm 1/2^\circ</math></p>		<p>DEFAULT PRINT TOL: (METRIC)</p> <p>FRACTIONS: <math>\pm 1\text{mm}</math></p> <p>.X= <math>\pm .25\text{mm}</math></p> <p>.XX= <math>\pm .13\text{mm}</math></p> <p>ANGLES: <math>\pm 1/2^\circ</math></p>		<p>CUSTOMER AUTHORIZATION: _____</p>	
<p>MATERIAL: (OTHER MATERIALS AVAILABLE UPON REQUEST)</p> <p><input type="checkbox"/> 1566 <input type="checkbox"/> 440C</p> <p><input type="checkbox"/> OTHER: _____</p>			<p>TITLE: <b>SHAFT REDUCTION 60 CASE TEMPLATE 6</b></p> <p>DRAWG NO. _____</p>		
<p>PLATING TYPE: _____</p> <p>APPROVAL DATE _____</p> <p>DRAWN BY DATE _____</p>		<p>DO NOT SCALE DRAWING</p>			
A	B	C	D	E	F

FAX A COPY OF THIS FORM TO QUOTATION DEPARTMENT, THOMSON 1-540-639-4162

<p><b>STD. MACHINED CHAMFER UNLESS NOTED IN ANGLE 'F' (TYP.)</b></p>	<p><b>SHAFT REDUCTION 60 CASE TEMPLATE 7</b></p>	<p><b>DO NOT SCALE DRAWING</b></p>	<p><b>DO NOT SCALE DRAWING</b></p>
<p>1</p>	<p>2</p>	<p>3</p>	<p>4</p>
<p>LENGTH 'A':</p> <p>DIAMETER 'D':</p> <p>CLASS:</p> <p>DIAMETER 'C':</p> <p>LENGTH 'E':</p> <p>ANGLE 'F':</p> <p>CHAMFER 'B':</p>		<p>DEFULT PRINT TOL: (INCH)</p> <p>FRACTIONS: ± 1/32"</p> <p>.X= ±.015"</p> <p>.XX= ±.010"</p> <p>.XXX= ±.005"</p> <p>ANGLES: ± 1/2°</p>	
<p>MATERIAL: (OTHER MATERIALS AVAILABLE UPON REQUEST)</p> <p><input type="checkbox"/> 1566 <input type="checkbox"/> 440C <input type="checkbox"/> 52100 TUBING</p> <p><input type="checkbox"/> OTHER: _____</p>		<p>DEFULT PRINT TOL: (METRIC)</p> <p>FRACTIONS: ± 1mm</p> <p>.X= ±.25mm</p> <p>.XX= ±.13mm</p> <p>ANGLES: ± 1/2°</p>	
<p>CUSTOMER AUTHORIZATION: _____</p>		<p>PLATING TYPE: _____</p> <p>APPROVAL DATE: _____</p> <p>DRAWN BY DATE: _____</p>	
<p>TITLE: <b>SHAFT REDUCTION 60 CASE TEMPLATE 7</b></p> <p>DRWG NO. _____</p>		<p>APPROVAL DATE: _____</p> <p>DRAWN BY DATE: _____</p>	

FAX A COPY OF THIS FORM TO QUOTATION DEPARTMENT, THOMSON 1-540-639-4162



A	B	C	D	E	F
<p><b>STD. MACHINED CHAMFER UNLESS NOTED IN ANGLE 'G' (TYP.)</b></p>					
<p><b>1</b></p>					
<p><b>2</b></p>					
<p><b>3</b></p>					
<p><b>4</b></p>					
<p>LENGTH 'A':</p>		<p>DIAMETER 'D':</p>		<p>CLASS:</p>	
<p>MIN. KEYWAY LENGTH 'C':</p>		<p>WIDTH 'E':</p>		<p>KEYWAY DEPTH 'F':</p>	
<p>ANGLE 'G':</p>		<p>CHAMFER 'B':</p>			
<p>DEFAULT PRINT TOL: (INCH) FRACTIONS: ± 1/32" .H= ±.015" .HH= ±.010" .HHH= ±.005" ANGLES: ± 1/2°</p>		<p>DEFAULT PRINT TOL: (METRIC) FRACTIONS: ± 1mm .H= ±.25mm .HH= ±.13mm ANGLES: ± 1/2°</p>		<p><b>THOMSON</b> Linear Motion. Optimized.<sup>™</sup></p> <p>TITLE: <b>KEYWAY SLOT 60 CASE TEMPLATE 8</b></p>	
<p>CUSTOMER AUTHORIZATION: _____</p>		<p>MATERIAL: (OTHER MATERIALS AVAILABLE UPON REQUEST)</p> <p><input type="checkbox"/> 1566 <input type="checkbox"/> 440C <input type="checkbox"/> 52100 TUBING</p> <p><input type="checkbox"/> OTHER: _____</p>		<p>APPROVAL _____ DATE _____</p> <p>DRAWN BY _____ DATE _____</p>	
		<p>PLATING TYPE: _____</p>		<p>DO NOT SCALE DRAWING</p>	
A	B	C	D	E	F

FAX A COPY OF THIS FORM TO QUOTATION DEPARTMENT, THOMSON 1-540-639-4162





A	B	C	D	E	F
<p>STD. MACHINED CHAMFER UNLESS NOTED IN ANGLE 'H'</p> <p>-.015 RAD. TYP.</p> <p>STD.</p>					
<p>LENGTH 'A': _____</p> <p>DIAMETER 'D': _____</p> <p>CLASS: _____</p> <p>DIAMETER 'C': _____</p> <p>LENGTH 'G': _____</p> <p>THREAD 'E': _____</p> <p>MIN. THREAD LENGTH 'F': _____</p> <p>ANGLE 'H': _____</p> <p>CHAMFER 'B': _____</p>					
<p>DEFAULT PRINT TOL: (INCH) FRACTIONS: ± 1/32" .H= ±.015" .HH= ±.010" .HHH= ±.005" ANGLES: ± 1/2°</p>		<p>DEFAULT PRINT TOL: (METRIC) FRACTIONS: ± 1mm .H= ±.25mm .HH= ±.13mm ANGLES: ± 1/2°</p>		<p>MATERIAL: (OTHER MATERIALS AVAILABLE UPON REQUEST)</p> <p><input type="checkbox"/> 1566 <input type="checkbox"/> 440C</p> <p><input type="checkbox"/> OTHER: _____</p>	
<p>CUSTOMER AUTHORIZATION: _____</p>					
<p>PLATING TYPE: _____</p>			<p>APPROVAL _____ DATE _____</p>		<p>DRAWN BY _____ DATE _____</p>
<p>DO NOT SCALE DRAWING</p>					
<p>THOMSON® Linear Motion. Optimized.™</p>		<p>SHAFT REDUCTION With THREAD 60 CASE TEMPLATE 10 DRAWG NO.</p>			

FAX A COPY OF THIS FORM TO QUOTATION DEPARTMENT, THOMSON 1-540-639-4162

1	2	3	4	A	B	C	D	E	F																		
<p style="text-align: center;">STD. MACHINED CHAMFER UNLESS NOTED IN ANGLE 'H' (TYP.)</p> <p style="text-align: center;">.015 RAD. (TYP.)</p> <p style="text-align: center;">B (TYP)</p>																											
<table border="1" style="width:100%; border-collapse: collapse;"> <tr> <td style="width: 50%;">LENGTH 'A':</td> <td style="width: 50%;"></td> </tr> <tr> <td>DIAMETER 'D':</td> <td></td> </tr> <tr> <td>CLASS:</td> <td></td> </tr> <tr> <td>DIAMETER 'E':</td> <td></td> </tr> <tr> <td>LENGTH 'F':</td> <td></td> </tr> <tr> <td>DIAMETER 'C':</td> <td></td> </tr> <tr> <td>LENGTH 'G':</td> <td></td> </tr> <tr> <td>ANGLE 'H':</td> <td></td> </tr> <tr> <td>CHAMFER 'B':</td> <td></td> </tr> </table>										LENGTH 'A':		DIAMETER 'D':		CLASS:		DIAMETER 'E':		LENGTH 'F':		DIAMETER 'C':		LENGTH 'G':		ANGLE 'H':		CHAMFER 'B':	
LENGTH 'A':																											
DIAMETER 'D':																											
CLASS:																											
DIAMETER 'E':																											
LENGTH 'F':																											
DIAMETER 'C':																											
LENGTH 'G':																											
ANGLE 'H':																											
CHAMFER 'B':																											
<p>DEFAULT PRINT TOL: (INCH) <math>\pm 1/32"</math></p> <p>FRACTIONS: .H= <math>\pm .015"</math></p> <p>.HX= <math>\pm .010"</math></p> <p>.HXX= <math>\pm .005"</math></p> <p>ANGLES: <math>\pm 1/2^\circ</math></p>			<p>DEFAULT PRINT TOL: (METRIC)</p> <p>FRACTIONS: <math>\pm 1mm</math></p> <p>.H= <math>\pm .25mm</math></p> <p>.HX= <math>\pm .13mm</math></p> <p>ANGLES: <math>\pm 1/2^\circ</math></p>			<p><b>THOMSON</b> Linear Motion. Optimized.<sup>™</sup></p> <p>MATERIAL: (OTHER MATERIALS AVAILABLE UPON REQUEST)</p> <p><input type="checkbox"/> 1566 <input type="checkbox"/> 440C <input type="checkbox"/> 52100 TUBING</p> <p><input type="checkbox"/> OTHER: _____</p>				<p>TITLE: <b>SHAFT REDUCTION 60 CASE TEMPLATE 11</b></p> <p>DRAWING NO. _____</p>																	
<p>CUSTOMER AUTHORIZATION: _____</p>			<p>PLATING TYPE: _____</p> <p>APPROVAL _____ DATE _____</p> <p>DO NOT SCALE DRAWING</p> <p>DRAWN BY _____ DATE _____</p>																								
<p><b>FAX A COPY OF THIS FORM TO QUOTATION DEPARTMENT, THOMSON 1-540-639-4162</b></p>																											



A	B	C	D	E	F																		
<table border="1" style="width: 100%; border-collapse: collapse;"> <tr> <td style="width: 50%;">LENGTH 'A':</td> <td style="width: 50%;">B (TYP)</td> </tr> <tr> <td>DIAMETER 'D':</td> <td></td> </tr> <tr> <td>CLASS:</td> <td></td> </tr> <tr> <td colspan="2" style="text-align: center;"><b>HOLE PATTERN</b></td> </tr> <tr> <td>DIAMETER 'E':</td> <td>LENGTH 'Y1': 'Y2':</td> </tr> <tr> <td>DEPTH 'C':</td> <td>LENGTH 'X':</td> </tr> <tr> <td>DIAMETER 'F':</td> <td>No. of Holes for 'X':</td> </tr> <tr> <td>ANGLE 'H':</td> <td></td> </tr> <tr> <td>CHAMFER 'B':</td> <td></td> </tr> </table>						LENGTH 'A':	B (TYP)	DIAMETER 'D':		CLASS:		<b>HOLE PATTERN</b>		DIAMETER 'E':	LENGTH 'Y1': 'Y2':	DEPTH 'C':	LENGTH 'X':	DIAMETER 'F':	No. of Holes for 'X':	ANGLE 'H':		CHAMFER 'B':	
LENGTH 'A':	B (TYP)																						
DIAMETER 'D':																							
CLASS:																							
<b>HOLE PATTERN</b>																							
DIAMETER 'E':	LENGTH 'Y1': 'Y2':																						
DEPTH 'C':	LENGTH 'X':																						
DIAMETER 'F':	No. of Holes for 'X':																						
ANGLE 'H':																							
CHAMFER 'B':																							
<table border="1" style="width: 100%; border-collapse: collapse;"> <tr> <td style="width: 25%; vertical-align: top;"> <b>THOMSON</b>  <i>Linear Motion. Optimized.</i> </td> <td colspan="2" style="vertical-align: top;">           MATERIAL: (OTHER MATERIALS AVAILABLE UPON REQUEST)  <input type="checkbox"/> 1566    <input type="checkbox"/> 440C  <input type="checkbox"/> OTHER: _____         </td> <td colspan="2" style="vertical-align: top;">           TITLE:  <b>DRILL &amp; COUNTER BORE            60 CASE TEMPLATE 12</b> </td> <td style="vertical-align: top;">           DRAWING NO.         </td> </tr> <tr> <td colspan="2" style="vertical-align: top;">           DEFAULT PRINT TOL: (METRIC)            FRACTIONS: ± 1mm            .R= ±.25mm            .RX= ±.13mm            ANGLES: ± 1/2°         </td> <td colspan="2" style="vertical-align: top;">           PLATING TYPE: _____            APPROVAL _____ DATE _____            DRAWN BY _____ DATE _____         </td> <td colspan="2" style="vertical-align: top;">           DO NOT SCALE DRAWING         </td> </tr> <tr> <td colspan="6" style="vertical-align: top;">           CUSTOMER AUTHORIZATION: _____         </td> </tr> </table>						<b>THOMSON</b> <i>Linear Motion. Optimized.</i>	MATERIAL: (OTHER MATERIALS AVAILABLE UPON REQUEST) <input type="checkbox"/> 1566 <input type="checkbox"/> 440C <input type="checkbox"/> OTHER: _____		TITLE: <b>DRILL &amp; COUNTER BORE            60 CASE TEMPLATE 12</b>		DRAWING NO.	DEFAULT PRINT TOL: (METRIC) FRACTIONS: ± 1mm .R= ±.25mm .RX= ±.13mm ANGLES: ± 1/2°		PLATING TYPE: _____ APPROVAL _____ DATE _____ DRAWN BY _____ DATE _____		DO NOT SCALE DRAWING		CUSTOMER AUTHORIZATION: _____					
<b>THOMSON</b> <i>Linear Motion. Optimized.</i>	MATERIAL: (OTHER MATERIALS AVAILABLE UPON REQUEST) <input type="checkbox"/> 1566 <input type="checkbox"/> 440C <input type="checkbox"/> OTHER: _____		TITLE: <b>DRILL &amp; COUNTER BORE            60 CASE TEMPLATE 12</b>		DRAWING NO.																		
DEFAULT PRINT TOL: (METRIC) FRACTIONS: ± 1mm .R= ±.25mm .RX= ±.13mm ANGLES: ± 1/2°		PLATING TYPE: _____ APPROVAL _____ DATE _____ DRAWN BY _____ DATE _____		DO NOT SCALE DRAWING																			
CUSTOMER AUTHORIZATION: _____																							

FAX A COPY OF THIS FORM TO QUOTATION DEPARTMENT, THOMSON 1-540-639-4162

<p>LENGTH 'A':</p> <p>DIAMETER 'D':</p> <p>CLASS:</p> <p>DIAMETER 'C':</p> <p>LENGTH 'Y':</p> <p>ANGLE 'E':</p> <p>CHAMFER 'B':</p>	<p>LENGTH 'A':</p> <p>DIAMETER 'D':</p> <p>CLASS:</p> <p>DIAMETER 'C':</p> <p>LENGTH 'Y':</p> <p>ANGLE 'E':</p> <p>CHAMFER 'B':</p>	<p>LENGTH 'A':</p> <p>DIAMETER 'D':</p> <p>CLASS:</p> <p>DIAMETER 'C':</p> <p>LENGTH 'Y':</p> <p>ANGLE 'E':</p> <p>CHAMFER 'B':</p>	<p>LENGTH 'A':</p> <p>DIAMETER 'D':</p> <p>CLASS:</p> <p>DIAMETER 'C':</p> <p>LENGTH 'Y':</p> <p>ANGLE 'E':</p> <p>CHAMFER 'B':</p>
<p>DEFAULT PRINT TOL: (INCH) FRACTIONS: ± 1/52" .X= ±.015" .XX= ±.010" .XXX= ±.005" ANGLES: ± 1/2°</p>	<p>DEFAULT PRINT TOL: (METRIC) FRACTIONS: ± 1mm .X= ±.25mm .XX= ±.13mm ANGLES: ± 1/2°</p>	<p>MATERIAL: (OTHER MATERIALS AVAILABLE UPON REQUEST)  <input type="checkbox"/> 1566 <input type="checkbox"/> 440C <input type="checkbox"/> 52100 TUBING  <input type="checkbox"/> OTHER: _____</p>	<p><b>THOMSON</b> Linear Motion. Optimized. TITLE: <b>THRU PIN HOLE</b> <b>60 CASE TEMPLATE 13</b> DRAWG NO. _____</p>
<p>CUSTOMER AUTHORIZATION: _____</p>		<p>PLATING TYPE: _____ APPROVAL _____ DATE _____ DRAWN BY _____ DATE _____</p>	<p>DO NOT SCALE DRAWING</p>

FAX A COPY OF THIS FORM TO QUOTATION DEPARTMENT, THOMSON 1-540-639-4162



	<p><b>THOMSON</b> Linear Motion. Optimized.<sup>™</sup></p>	<p>OTHER MATERIALS AVAILABLE UPON REQUEST</p> <p>MATERIAL: <input type="checkbox"/> 1566 <input type="checkbox"/> 440C <input type="checkbox"/> 52100 TUBING <input type="checkbox"/> OTHER: _____</p>	<p>TITLE: <b>MACHINED SLOTS</b> <b>60 CASE TEMPLATE 15</b></p> <p>DRWG NO. _____</p>
<p>STANDARD TOLERANCES (UNLESS NOTED OTHERWISE):</p> <p>LENGTH 'A': _____</p> <p>DIAMETER 'D': _____</p> <p>CLASS: _____</p> <p>LENGTH 'Y': _____</p> <p>LENGTH 'C': _____</p> <p>DEPTH 'E': _____</p> <p>ANGLE 'F': _____</p> <p>CHAMFER 'B': _____</p>	<p>DEFAULT PRINT TOL: (METRIC)</p> <p>FRACTIONS: ± 1mm</p> <p>.R= ±.25mm</p> <p>.RH= ±.13mm</p> <p>ANGLES: ± 1/2°</p>	<p>PLATING TYPE: _____</p> <p>APPROVAL _____ DATE _____</p> <p>DRAWN BY _____ DATE _____</p> <p>DO NOT SCALE DRAWING</p>	<p>CUSTOMER AUTHORIZATION: _____</p>

FAX A COPY OF THIS FORM TO QUOTATION DEPARTMENT, THOMSON 1-540-639-4162



<p style="text-align: center;">STD. MACHINED CHAMFER UNLESS NOTED IN ANGLE 'F' (TYP.)</p> <p style="text-align: center;">STD. RELIEF</p> <p style="text-align: center;">SPlice LOCATION(S)</p> <p style="text-align: center;">B (TYP)</p>	<p style="text-align: center;"><b>HOLE PATTERN</b></p> <p style="text-align: center;">SPlice LOCATION(S)</p>	<p style="text-align: center;">MATERIAL: (OTHER MATERIALS AVAILABLE UPON REQUEST)</p> <p style="text-align: center;"><input type="checkbox"/> 1566    <input type="checkbox"/> 440C</p> <p style="text-align: center;"><input type="checkbox"/> OTHER:</p>	<p style="text-align: center;"><b>THOMSON</b><sup>®</sup> <i>Linear Motion. Optimized.™</i></p> <p style="text-align: center;">TITLE: <b>DOWEL JOINT</b> <b>60 CASE TEMPLATE 17</b></p> <p style="text-align: center;">DRUG NO.</p>
<p>LENGTH 'A':</p> <p>DIAMETER 'D':</p> <p>CLASS:</p>	<p>LENGTH 'Y1':</p> <p>LENGTH 'Y2':</p> <p>No. of Holes for 'H':</p>	<p>DEFAULT PRINT TOL: (INCH)</p> <p>FRACTIONS: ± 1/32"</p> <p>.H= ±.015"</p> <p>.HH= ±.010"</p> <p>.HHH= ±.005"</p> <p>ANGLES: ± 1/2°</p>	<p>DEFAULT PRINT TOL: (METRIC)</p> <p>FRACTIONS: ± 1mm</p> <p>.H= ±.25mm</p> <p>.HH= ±.13mm</p> <p>ANGLES: ± 1/2°</p>
<p>THREAD 'E':</p> <p>ANGLE 'F':</p> <p>CHAMFER 'B':</p>	<p>CUSTOMER AUTHORIZATION:</p>	<p>PLATING TYPE:</p> <p>APPROVAL</p> <p>DATE</p> <p>DO NOT SCALE DRAWING</p>	<p>APPROVAL</p> <p>DATE</p> <p>DRAWN BY</p> <p>DATE</p>

FAX A COPY OF THIS FORM TO QUOTATION DEPARTMENT, THOMSON 1-540-639-4162



## RoundRail Linear Guides

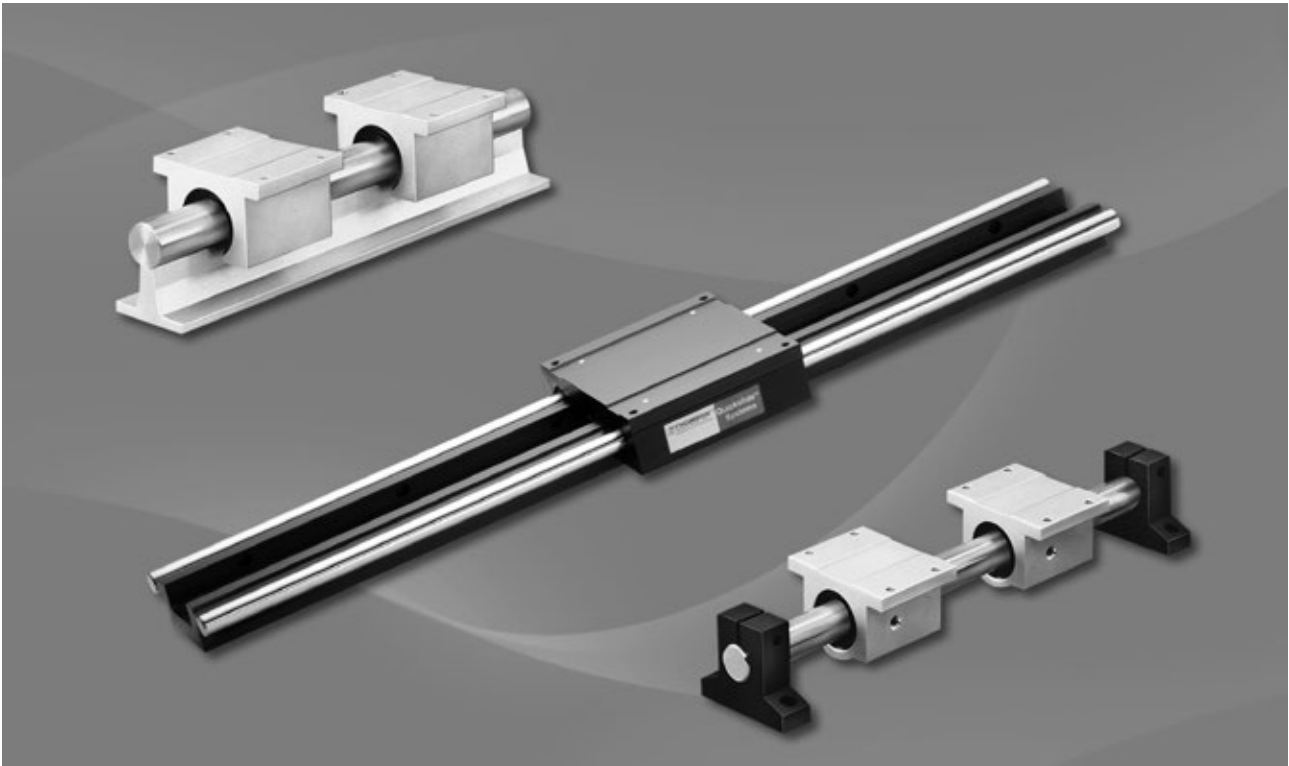

<b>RoundRail Linear Guides</b> .....	<b>228</b>
End Support 1BA.....	231
End Support 1NA .....	233
Continuous Support 1CA .....	235
Continuous Support 1PA.....	238
FluoroNyliner® 1VA.....	240
Side Mounted 1DA.....	243
Dual Shaft Rail 2DA.....	246
Twin Shaft Web 2CA.....	249
Accessories.....	252

Pre-assembled, ready-to-install stages providing low friction, smooth, accurate motion for a wide range of moment or normal loading configurations. Market applications include factory automation, medical, packaging, machine tool, semiconductor, printing, automotive assembly, aerospace and food processing. Slide tables are available as customizable linear guides to multi-axis, turnkey systems complete with motors, drives, controls and electromechanical accessories.

- Applications typically on factory machinery where accurate, smooth linear positioning is required.
- Available with servo/stepper motor and drive packages.
- Max thrust to 3100 lb.
- Strokes to 120".
- Loads from 5 - 2000 lb.
- Repeatability to 0.0002".

RoundRail linear guides are the non-driven building blocks for linear slide tables. They offer the end user flexibility to fit specific envelopes by allowing customized separations between shafts and between bearings on shafts to produce higher moment capacity. When combined with ball screw assemblies, they become a driven slide table.

Because RoundRail linear guides are offered in a wide range of sizes, bearing types and mounting configurations, they are typically selected by the qualitative attributes that are most appropriate for a given application (i.e. environmental considerations, mounting footprint). For this reason, we are providing the following selection chart and selection criteria for consideration:

### Systems Quick Reference Guide

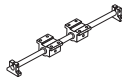
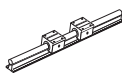
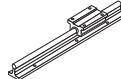
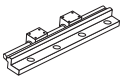
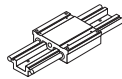
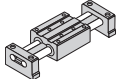
Application Criteria	End Support	Continuous Support	FluoroNyliner	Side Mounted	Dual Shaft Rail	Twin Shaft Web
						
	<b>1BA / 1NA</b>	<b>1CA / 1PA</b>	<b>1VA</b>	<b>1DA</b>	<b>2DA</b>	<b>2CA</b>
<b>High Loads</b>		•	•			
<b>Equivalent Loads in All Directions</b>	•				•	
<b>Ultra Compactness</b>	•					•
<b>Extreme Smoothness</b>	•	•		•		•
<b>End Supported</b>	•				•	•
<b>Single Rail</b>						•
<b>Harsh Environment</b>			•			
<b>Low-Cost Installation (multiple rail)</b>	•	•	•	•		
<b>Complete Axis Solution</b>						•
<b>Available Sizes:</b>	<b>Inch</b>	4 thru 24	8 thru 24	8 thru 24	•	•
	<b>Metric</b>	8 thru 40	12 thru 40		8 thru 16	8 thru 16
<b>Page Number</b>	231/233	236/238	241	244	247	250

### Linear Guide Selection Criteria

- Load/Life
- Travel Accuracy
- Rigidity
- Smoothness of Travel
- Speed & Acceleration
- Envelope
- Environment
- Cost of Product
- Cost of Installation
- Cost of Replacement

### Application Examples

- Machine Tools
- Packaging Machinery
- Automotive Assembly Equipment
- Semiconductor Equipment
- Medical Equipment
- Food Processing Equipment



## End Support Linear Ball Guides

**Easy to install, smooth operation,  
self aligning, high speed**

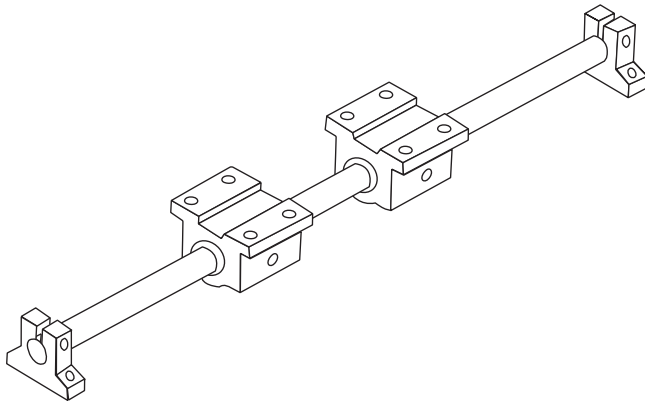

### **End Support Linear Ball Guides Offer:**

- Increased life within the same envelope. RoundRail linear guides feature the new patented Super Smart Ball Bushing® Bearings for up to 216X the life or 6X the load capacity of conventional bearings.
- Cost savings: save time and money preparing your mounting surfaces before bolting down RoundRail linear guides.
- End supported for gantry style or 'bridge' applications.
- The RoundRail Advantage. The inherent self-aligning-in-all-directions design of the Super Smart Ball Bushing Bearing allows for ultra-smooth travel when mounted to wider-toleranced prepared surfaces.
- The Super Smart Ball Bushing Bearing... the most technologically advanced and most robust linear bearing in the world.
- Corrosion-resistant versions for maximum performance in harsh environments.

# End Support 1BA

## End-Supported, Industry Standard Dimension Inch

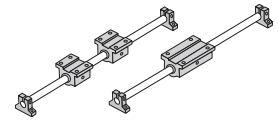

### Features

- Requires only one part number to specify entire linear guide.
- Available with 60 Case® LinearRace® shaft end support blocks in either lightweight aluminum or rigid iron materials.
- Used to provide increased stability or torque resistance in linear system applications.

### Components

- 2 Super Smart Ball Bushing pillow blocks or 1 Super Smart Ball Bushing twin pillow block.
- 1 60 Case LinearRace shaft.
- 2 shaft end support blocks.

### Specifying this Thomson Linear Guide

1. Determine the proper Linear Guide for your load and life requirements.
2. Select the part number.
3. Add the letter "L" followed by the overall length in inches, as a suffix to the part number.

### Part Numbering System

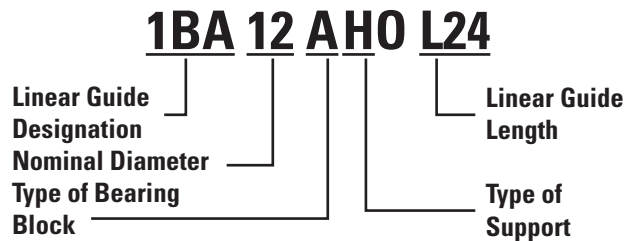

### Dimensions (Inch)

#### Type ASB End Support Block

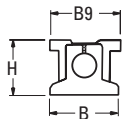

#### Type SB End Support Block

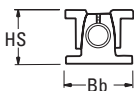

#### Type SSUPB Super Smart and SPB Super Ball Bushing Pillow Blocks

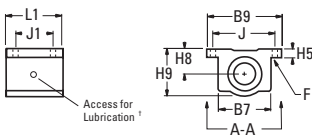

#### Type SSUTWN Super Smart and TWN Super Ball Bushing Twin Pillow Blocks

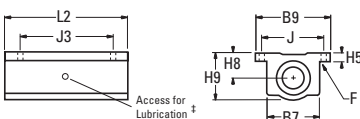

‡ Sizes .250, .375 and .500 have oil lubricant fitting. Sizes .625 and above have 1/4-28 access for lubrication.

#### Single End Supported Linear Guide with 2 Pillow Blocks

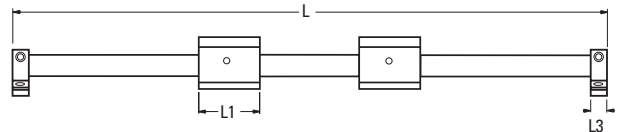

#### Single End Supported Linear Guide with 1 Twin Pillow Block

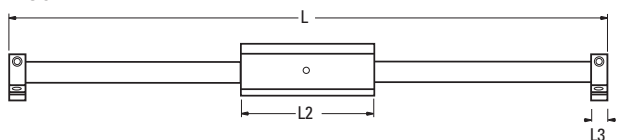

### Aluminum

#### Type ASB LinearRace Shaft End Support Block

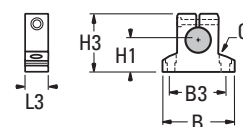

### Steel

#### Type SB LinearRace Shaft End Support Block

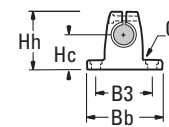

#### Type SPB Super Ball Bushing Pillow Block Mounting Hole Position for Sizes .250 and .375

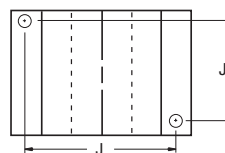

View A-A



### End-Support Linear Guide 1BA with 2 Pillow Blocks (Dimensions in inches)

Part Number		Nominal Diameter	L1	L3	H	HS	B	Bb	B9	Pillow Block	Shaft Support	
With Type ASB Shaft Supports	With Type SB Shaft Supports										Type ASB	Type SB
1BA04AHO	–	.250	1.19	.50	.937	–	1.50	–	1.63	SPB4-XS	ASB4-XS	–
1BA06AHO	–	.375	1.31	.56	10.62	–	1.63	–	1.75	SPB6-XS	ASB6-XS	–
1BA08AHO	1BA08AJ0	.500	1.69	.63	1.562	1.687	2.00	2.00	2.00	SSUPB8-XS	ASB8-XS	SB8-XS
1BA12AHO	1BA12AJ0	.750	2.06	.75	2.062	2.187	2.50	2.75	2.75	SSUPB12-XS	ASB12-XS	SB12-XS
1BA16AHO	1BA16AJ0	1.000	2.81	1.00	2.562	2.687	3.25	3.25	3.25	SSUPB16-XS	ASB16-XS	SB16-XS
–	1BA20AJ0	1.250	3.63	1.13	–	3.250	–	–	4.00	SSUPB20-XS	–	SB20-XS
1BA24AHO	1BA24AJ0	1.500	4.00	1.25	3.750	3.750	4.75	4.75	4.75	SSUPB24-XS	ASB24-XS	SB24-XS

### End-Support Linear Guide 1BA with 1 Twin Pillow Block (Dimensions in inches)

Part Number		Nominal Diameter	L2	L3	H	HS	B	Bb	B9	Max Stroke Length	Pillow Block	Shaft Support	
With Type ASB Shaft Supports	With Type SB Shaft Supports											Type ASB	Type SB
1BA04BHO	–	.250	2.50	.50	.937	–	1.50	–	1.63	L-(3.50)	TWN4-XS	ASB4-XS	–
1BA06BHO	–	.375	2.75	.56	10.62	–	1.63	–	1.75	L-(3.88)	TWN6-XS	ASB6-XS	–
1BA08BHO	1BA08BJ0	.500	3.50	.63	1.562	1.687	2.00	2.00	2.00	L-(4.75)	SSUTWN8-XS	ASB8-XS	SB8-XS
1BA12BHO	1BA12BJ0	.750	4.50	.75	2.062	2.187	2.50	2.75	2.75	L-(6.00)	SSUTWN12-XS	ASB12-XS	SB12-XS
1BA16BHO	1BA16BJ0	1.000	6.00	1.00	2.562	2.687	3.25	3.25	3.25	L-(8.00)	SSUTWN16-XS	ASB16-XS	SB16-XS
–	1BA20BJ0	1.250	7.50	1.13	–	3.250	–	–	4.00	L-(9.75)	SSUTWN20-XS	–	SB20-XS
1BA24BHO	1BA24BJ0	1.500	9.00	1.25	3.750	3.750	4.75	4.75	4.75	L-(11.50)	SSUTWN24-XS	ASB24-XS	SB24-XS

Shaft Deflection Note: Load limit may be below the dynamic load rating due to shaft deflection. Bearings can accommodate up to 1/2° deflection. See Engineering section (page 269) for Deflection calculations.

### Dynamic Load Capacity Matrix (4 million inches travel)

Linear Guide Assembly Part Number	Dynamic Load Capacity (lb.) (Even Distribution)	Pillow Block Part Number	Pillow Block Dynamic Load Capacity (lb.)
1BA04AHO	100	SPB4-XS	50
1BA06AHO	160	SPB6-XS	80
1BA08AHO	800	SSUPB8-XS	400
1BA12AHO	1800	SSUPB12-XS	900
1BA16AHO	3000	SSUPB16-XS	1500
–	3730	SSUPB20-XS	1865
1BA24AHO	6160	SSUPB24-XS	3080

### Dynamic Load Capacity Matrix (4 million inches travel)

Linear Guide Assembly Part Number	Dynamic Load Capacity (lb.) (Even Distribution)	Pillow Block Part Number	Pillow Block Dynamic Load Capacity (lb.)
1BA04BHO	100	TWN4-XS	100
1BA06BHO	160	TWN6-XS	160
1BA08BHO	800	SSUTWN8-XS	800
1BA12BHO	1800	SSUTWN12-XS	1800
1BA16BHO	3000	SSUTWN16-XS	3000
–	3730	SSUTWN20-XS	3730
1BA24BHO	6160	SSUTWN24-XS	6160

† Super Ball Bushing Bearings are used in .250 and .375 inch size pillow blocks.

## Replacement Component Dimensions

### Type SPB and SSUPB Pillow Blocks (Dimensions in inches)

Part Number	Nom. Dia.	L1	H9	H8	H5	B9	B7	J	J1	F		Wt. (lb)
										Bolt	Hole	
SPB4-XS	.250	1.19	.81	.437	.19	1.63	1.00	1.31	.75 <sup>(2)</sup>	#6	.16	.10
SPB6-XS	.375	1.31	.94	.500	.19	1.75	1.12	1.44	.88 <sup>(2)</sup>	#6	.16	.13
SSUPB8-XS	.500	1.69	1.25	.687	.25	2.00	1.38	1.69	1.00	#6	.16	.20
SSUPB12-XS	.750	2.06	1.75	.937	.31	2.75	1.88	2.38	1.25	#8	.19	.62
SSUPB16-XS	1.000	2.81	2.19	1.187	.38	3.25	2.38	2.88	1.75	#10	.22	1.24
SSUPB20-XS	1.250	3.63	2.81	1.500	.43	4.00	3.00	3.50	2.00	#10	.22	2.57
SSUPB24-XS	1.500	4.00	3.25	1.750	.50	4.75	3.50	4.12	2.50	1/4	.28	3.94

Housing Material: Aluminum Alloy Black Anodized. (2) Two mounting holes as shown in view A-A for sizes .250 and

### Type TWN and SSUTWN Pillow Blocks

Part Number	Nom. Dia.	L2	J3	Wt. (lb)
TWN4-XS	.25	2.50	2.00	.19
TWN6-XS	.375	2.75	2.25	.25
SSUTWN8-XS	.500	3.50	2.50	.40
SSUTWN12-XS	.750	4.50	3.50	1.24
SSUTWN16-XS	1.000	6.00	4.50	2.48
SSUTWN20-XS	1.250	7.50	5.50	5.14
SSUTWN24-XS	1.500	9.00	6.50	8.08

Housing Material: Aluminum Alloy Black Anodized .375.

### Type ASB LinearRace Shaft End-Support Block (Dim. in in.)

Part Number	Nom. Dia.	L3	H3	H1	B	B3	F		Wt. (lb)
							Bolt	Hole	
ASB4-XS	.250	.50	.88	.500	1.50	1.12	#6	.16	.06
ASB6-XS	.375	.56	1.00	.562	1.62	1.25	#6	.16	.08
ASB8-XS	.500	.63	1.48	.875	2.00	1.50	#8	.19	.11
ASB12-XS	.750	.75	1.95	1.125	2.50	2.00	#10	.22	.22
ASB16-XS	1.000	1.00	2.48	1.375	3.25	2.50	1/4	.28	.44
ASB24-XS	1.500	1.25	3.50	2.000	4.75	3.50	5/16	.34	1.16

End-Support Material: Aluminum Alloy Black Anodized

### Type SB LinearRace® Shaft End-Support Block (Dim. in in.)

Part Number	Nom. Dia.	L3	Hh	Hc	Bb	B3	F		Wt. (lb)
							Bolt	Hole	
SB8-XS	.500	.63	1.62	1.000	2.00	1.50	#8	.16	.3
SB12-XS	.750	.75	2.12	1.250	2.75	2.00	#10	.16	.5
SB16-XS	1.000	1.00	2.56	1.500	3.25	2.50	1/4	.19	1.0
SB20-XS	1.250	1.13	3.00	1.750	4.00	3.00	5/16	.22	2.0
SB24-XS	1.500	1.25	3.50	2.000	4.75	3.50	5/16	.28	2.6

Material: Iron

# End Support 1NA

## End-Supported, Industry Standard Dimension Metric

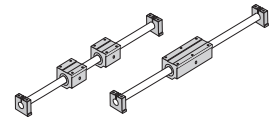

### Features

- Requires only one part number to specify entire linear guide.
- Available with 60 Case® LinearRace® shaft end support blocks in either lightweight aluminum or rigid iron materials.
- Used to provide increased stability or torque resistance in linear system applications.

### Components

- 2 Super Smart Ball Bushing® pillow blocks or 1 Super Smart Ball Bushing twin pillow block.
- 1 60 Case LinearRace shaft.
- 2 shaft end support blocks.

### Specifying this Thomson Linear Guide

1. Determine the proper linear guide for your load and life requirements.
2. Select the part number.
3. Add the letter "L" followed by the overall length in inches, as a suffix to the part number.

### Part Numbering System

**1NA M12 NMO L600**

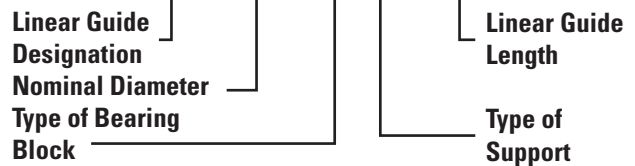

### Dimensions (Inch)

#### Type ASB End Support Block

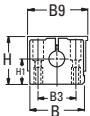

#### Type SB End Support Block

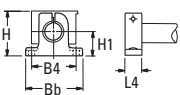

#### Type SPPB Super and SSEPB Super Smart Ball Bushing Pillow Blocks

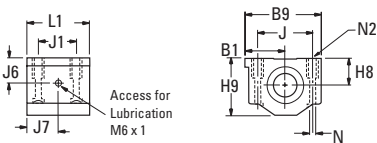

#### Type SPTWN Super and SSETWN Super Smart Ball Bushing Twin Pillow Blocks

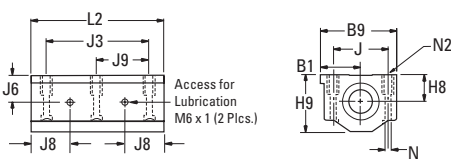

#### Supported Linear Guide with 2 Pillow Blocks

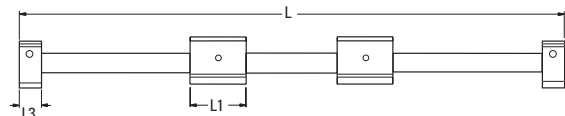

#### Supported Linear Guide with 1 Twin Pillow Block

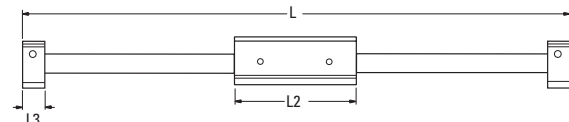

Maximum Stroke Length is determined by subtracting pillow block length (L2) and 2x support block length (L3) or (L4) from total Linear Guide length (L).

### Aluminum

Type ASB LinearRace Shaft End Support Block

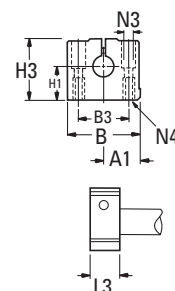

### Steel

Type SB LinearRace Shaft End Support Block

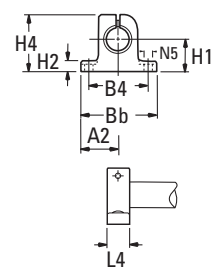



### End-Support Linear Guide 1NA with 2 Pillow Blocks (Dimensions in mm)

Part Number		Nom. Dia.	L1	L3	L4	H	H1	B	Bb	B9	Pillow Block	Shaft Support	
With Type ASB Shaft Supports	With Type SB Shaft Supports											Type ASB	Type SB
1NAM08NMO	1NAM08NNO	8	32	18	10	30	15	32	32	35	SPPBM08-XS	ASBM08-XS	SBM08-XS
1NAM12NMO	1NAM12NNO	12	39	20	12	38	20	43	42	43	SSEPBM12-XS	ASBM12-XS	SBM12-XS
1NAM16NMO	1NAM16NNO	16	43	24	16	47	25	43	50	53	SSEPBM16-XS	ASBM16-XS	SBM16-XS
1NAM20NMO	1NAM20NNO	20	54	30	20	55	30	60	60	60	SSEPBM20-XS	ASBM20-XS	SBM20-XS
1NAM25NMO	1NAM25NNO	25	67	38	25	65	35	78	74	78	SSEPBM25-XS	ASBM25-XS	SBM25-XS
1NAM30NMO	1NAM30NNO	30	79	40	28	75	40	87	84	87	SSEPBM30-XS	ASBM30-XS	SBM30-XS
1NAM40NMO	1NAM40NNO	40	91	48	32	95	50	108	108	108	SSEPBM40-XS	ASBM40-XS	SBM40-XS

### End-Support Linear Guide 1NA with 1 Twin Pillow Block (Dimensions in mm)

Part Number		Nom. Dia.	L2	L3	L4	H	H1	B	Bb	B9	Pillow Block	Shaft Support	
With Type ASB Shaft Supports	With Type SB Shaft Supports											Type ASB	Type SB
1NAM08PMO	1NAM08PNO	8	62	18	10	30	15	32	32	35	SPTWNM08-XS	ASBM08-XS	SBM08-XS
1NAM12PMO	1NAM12PNO	12	76	20	12	38	20	43	42	43	SSETWNM12-XS	ASBM12-XS	SBM12-XS
1NAM16PMO	1NAM16PNO	16	84	24	16	47	25	43	50	53	SSETWNM16-XS	ASBM16-XS	SBM16-XS
1NAM20PMO	1NAM20PNO	20	104	30	20	55	30	60	60	60	SSETWNM20-XS	ASBM20-XS	SBM20-XS
1NAM25PMO	1NAM25PNO	25	130	38	25	65	35	78	74	78	SSETWNM25-XS	ASBM25-XS	SBM25-XS
1NAM30PMO	1NAM30PNO	30	152	40	28	75	40	87	84	87	SSETWNM30-XS	ASBM30-XS	SBM30-XS
1NAM40PMO	1NAM40PNO	40	176	48	32	95	50	108	108	108	SSETWNM40-XS	ASBM40-XS	SBM40-XS

Shaft Deflection Note: Load limit may be below the dynamic load rating due to shaft deflection. Bearings can accommodate up to 1/2° deflection. See Engineering section (page 269) for Deflection calculations.

### Dynamic Load Capacity Matrix (100 km travel)

Linear Guide Assembly Part Number	Dynamic Load Capacity (lb.) (Even Distribution)	Pillow Block Part Number	Pillow Block Dynamic Load Capacity (lb.)
1NAM08NMO	100	SPPBM08-XS	50
1NAM12NMO	160	SSEPBM12-XS	80
1NAM16NMO	800	SSEPBM16-XS	400
1NAM20NMO	1800	SSEPBM20-XS	900
1NAM25NMO	3000	SSEPBM25-XS	1500
1NAM30NMO	3730	SSEPBM30-XS	1865
1NAM40NMO	6160	SSEPBM40-XS	3080

### Dynamic Load Capacity Matrix (100 km travel)

Linear Guide Assembly Part Number	Dynamic Load Capacity (lb.) (Even Distribution)	Pillow Block Part Number	Pillow Block Dynamic Load Capacity (lb.)
1NAM08PMO	100	SPTWNM08-XS	100
1NAM12PMO	160	SSETWNM12-XS	160
1NAM16PMO	800	SSETWNM16-XS	800
1NAM20PMO	1800	SSETWNM20-XS	1800
1NAM25PMO	3000	SSETWNM25-XS	3000
1NAM30PMO	3730	SSETWNM30-XS	3730
1NAM40PMO	6160	SSETWNM40-XS	6160

† Super Ball Bushing® Bearings are used in 8 mm size pillow blocks.

## Replacement Component Dimensions

### Type SPPB and SSEPB Pillow Blocks (Dimensions in mm)

Part Number	Nom. Dia.	L1	H8	H9	B1	B9	J	J1	J6	J7	N Dia.	N2	Mass (kg)
SPPBM08-XS	8	32	15	28	17.5	35	25	20	15	19.5	3.3	M4	0.07
SSEPBM12-XS	12	39	18	35	21.5	43	32	23	18	23.0	4.3	M5	0.13
SSEPBM16-XS	16	43	22	42	26.5	53	40	26	22	25.0	5.3	M6	0.20
SSEPBM20-XS	20	54	25	50	30.0	60	45	32	25	30.5	6.6	M8	0.35
SSEPBM25-XS	25	67	30	60	39.0	78	60	40	30	37	8.4	M10	0.66
SSEPBM30-XS	30	79	35	70	43.5	87	68	45	35	43	8.4	M10	0.99
SSEPBM40-XS	40	91	45	90	54.0	108	86	58	45	49	10.5	M12	1.83

Housing Material: Aluminum Alloy Grey Anodized.

### Type SPTWN and SSETWN Pillow Blocks

Part Number	Nom. Dia.	L2	J3	J8	J9	Mass (kg)
SPTWNM08-XS	8	62	50	19.5	25	0.15
SSETWNM12-XS	12	76	56	23.0	28	0.27
SSETWNM16-XS	16	84	64	25.0	32	0.41
SSETWNM20-XS	20	104	76	30.5	38	0.73
SSETWNM25-XS	25	130	94	37.0	47	1.37
SSETWNM30-XS	30	152	106	43.0	53	2.04
SSETWNM40-XS	40	176	124	49.0	62	3.73

Housing Material: Aluminum Alloy Grey Anodized

### Type ASB LinearRace Shaft End Support Block (Dim. in mm)

Part Number	Nom. Dia.	A1	B	B3	H1	H3	L3	N3 Bolt	N4	Mass (kg)
ASBM08-XS	8	16.0	32	22	15	28	18	3.5	M4	0.04
ASBM12-XS	12	21.5	43	30	20	36	20	5.3	M6	0.10
ASBM16-XS	16	26.5	53	38	25	43	24	6.6	M8	0.15
ASBM20-XS	20	30.0	60	42	30	51	30	8.4	M10	0.23
ASBM25-XS	25	39.0	78	56	35	61	38	10.5	M12	0.41
ASBM30-XS	30	43.5	87	64	40	71	40	10.5	M12	0.53
ASBM40-XS	40	54.0	108	82	50	88	48	13.5	M16	0.99

End Support Material: Aluminum Alloy Grey Anodized

### Type SB LinearRace Shaft End Support Block (Dim. in mm)

Part Number	Nom. Dia.	A2	B4	Bb	H1	H2	H4	L4	N5 Dia.	Mass (kg)
SBM08-XS	8	16	25	32	15	5.2	27	10	4.5	0.03
SBM12-XS	12	21	32	42	20	5.5	35	12	5.5	0.06
SBM16-XS	16	25	40	50	25	6.5	42	16	5.5	0.11
SBM20-XS	20	30	45	60	30	8.0	50	20	5.5	0.21
SBM25-XS	25	37	60	74	35	9.0	58	25	6.6	0.35
SBM30-XS	30	42	68	84	40	10.0	68	28	9.0	0.52
SBM40-XS	40	54	86	108	50	12.0	86	32	11.0	0.92

End Support Material: Iron

## Continuous Support Linear Ball Guides

**High speed, smooth operation,  
easy to install**

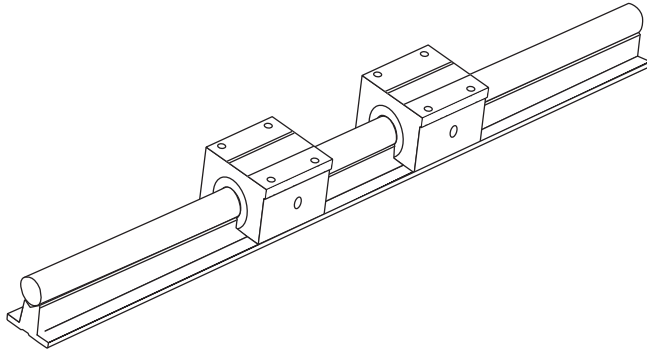

### **Continuous Support Linear Ball Guides Offer:**

- Increased life within the same envelope. RoundRail linear guides feature the new patented Super Smart Ball Bushing® Bearings for up to 216X the life or 6X the load capacity of conventional bearings.
- Cost savings: save time and money preparing your mounting surfaces before bolting down RoundRail linear guides.
- Superior performance. Continuously supported for maximum down- and side-load applications without concerns for shaft deflection.
- The RoundRail Advantage. The inherent self-aligning-in-all-directions design of the Super Smart Ball Bushing Bearing allows for ultra-smooth travel when mounted to wider-toleranced prepared surfaces.
- Unlimited travel lengths without concerns for machined reference edges or butt joint alignment.
- The Super Smart Ball Bushing Bearing... the most technologically advanced and most robust linear bearing in the world.



# Continuous Support 1CA

Fully Supported, Highest Performance, Industry Standard Dimension Inch

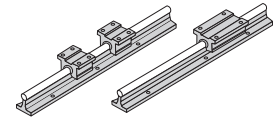

## Features

- Requires only one part number to specify the entire linear guide.
- Used as a load support, transport and guidance solution.
- Used in continuously supported applications when rigidity is required.

## Components

- 2 Super Smart Ball Bushing® open type pillow blocks or 1 Super Smart Ball Bushing open twin pillow blocks.
- 1 60 Case® LinearRace® shaft support rail assembly.

## Specifying this Thomson Linear Guide

1. Determine the proper linear guide for your load and life requirements.
2. Select the part number.
3. Add the letter "L" followed by the overall length in inches, as a suffix to the part number.

## Part Numbering System

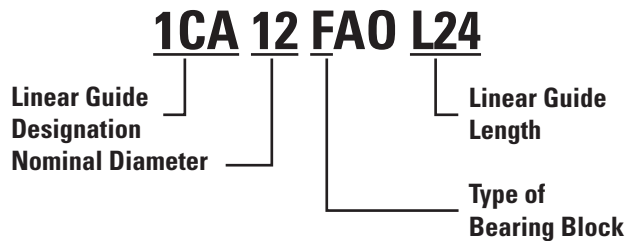

## Dimensions (Inch)

Single Continuously Supported Linear Guide with 2 Pillow Blocks

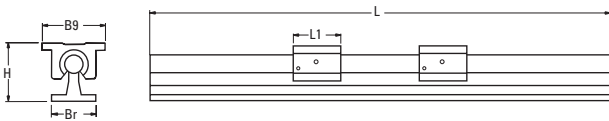

Single Continuously Supported Linear Guide with 1 Twin Pillow Block

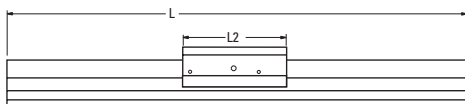

Type SSUPBO Open Type Super Smart and SPB-OPN Open Type Ball Bushing Pillow Blocks

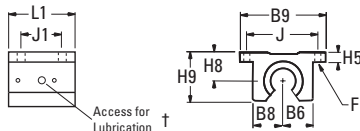

Type SSUTWN Open Type Super Smart and TWN-OPN Open Type Ball Bushing Twin Pillow Blocks

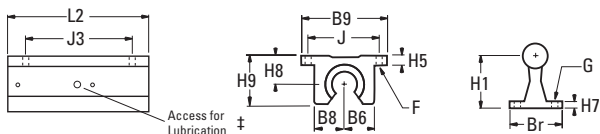

## Load Rating and Limit by Direction

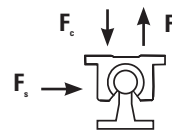

	Dynamic Load Rating	Load Limit
$F_c$	C	C
$F_t$	0.5C	0.5C
$F_s$	C	0.5C

Dynamic Load Rating: Load value used in life calculation.  
 Load Limit: Maximum allowable load applied to bearing.

## Type SRA LinearRace Shaft Support Rail Assembly

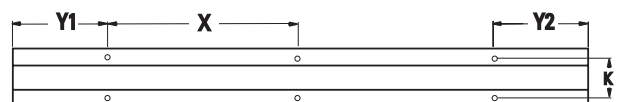

† Size .500 inch has oil lubricant fitting.  
 ‡ Sizes .625 and above have 1/4-28 access for lubrication.

**Continuously Supported Linear Guide 1CA Single with 2 Pillow Blocks** (Dimensions in inches)

Part Number	Nominal Diameter	L1	H	Br	B9	Pillow Block	Shaft Support Rail Assembly
1CA08FAO	.500	1.50	1.812	1.50	2.00	SPB80PN-XS	SRA8-XS
1CA12FAO	.750	1.88	2.437	1.75	2.75	SSUPB012-XS	SRA12-XS
1CA16FAO	1.000	2.63	2.937	2.13	3.25	SSUPB016-XS	SRA16-XS
1CA20FAO	1.250	3.38	3.625	2.50	4.00	SSUPB020-XS	SRA20-XS
1CA24FAO	1.500	3.75	4.250	3.00	4.75	SSUPB024-XS	SRA24-XS

**Continuously Supported Linear Guide 1CA Single with 1 Twin Pillow Block** (Dimensions in inches)

Part Number	Nominal Diameter	L2	H	Br	B9	Maximum Stroke Length	Pillow Block	Shaft Support Rail Assembly
1CA08HAO	.50	3.5	1.812	1.50	2.00	L-(3.5)	TWN80PN-XS	SRA8-XS
1CA12HAO	.75	4.5	2.437	1.75	2.75	L-(4.5)	SSUTWNO12-XS	SRA12-XS
1CA16HAO	1.00	6.0	2.937	2.13	3.25	L-(6.0)	SSUTWNO16-XS	SRA16-XS
1CA20HAO	1.25	7.5	3.625	2.50	4.00	L-(7.5)	SSUTWNO20-XS	SRA20-XS
1CA24HAO	1.50	9.0	4.250	3.00	4.75	L-(9.0)	SSUTWNO24-XS	SRA24-XS

**Dynamic Load Capacity Matrix** (4 million inches travel)

Linear Guide Assembly Part Number	Dynamic Load Capacity (lb.) (Even Distribution)	Pillow Block Part Number	Pillow Block Dynamic Load Capacity (lb.)
1CA08FAO	290	SPB80PN-XS	400
1CA12FAO	1800	SSUPB012-XS	900
1CA16FAO	3000	SSUPB016-XS	1500
1CA20FAO	3730	SSUPB020-XS	1865
1CA24FAO	6160	SSUPB024-XS	3080

**Dynamic Load Capacity Matrix** (4 million inches travel)

Linear Guide Assembly Part Number	Dynamic Load Capacity (lb.) (Even Distribution)	Pillow Block Part Number	Pillow Block Dynamic Load Capacity (lb.)
1CA08HAO	290	TWN80PN-XS	800
1CA12HAO	1800	SSUTWNO12-XS	1800
1CA16HAO	3000	SSUTWNO16-XS	3000
1CA20HAO	3730	SSUTWNO20-XS	3730
1CA24HAO	6160	SSUTWNO24-XS	6160

† Super Ball Bushing Bearings are used in .500 inch size pillow blocks.

**Replacement Component Dimensions**

**Type SPB-OPN and SSUPB0 Pillow Blocks** (Dimensions in inches)

Part Number	Nom. Dia.	L1	H9	H8	H5	B9	B8	B6	J	J1	F		Wt. (lb)
											Bolt	Hole	
SPB80PN-XS	.500	1.69	1.25	.687	.25	2.00	.75	.69	1.69	1.00	#6	.16	.20
SSUPB012-XS	.750	2.06	1.75	.937	.31	2.75	1.00	.94	2.38	1.25	#8	.19	.62
SSUPB016-XS	1.000	2.81	2.19	1.187	.38	3.25	1.25	1.19	2.88	1.75	#10	.22	1.24
SSUPB020-XS	1.250	3.63	2.81	1.500	.43	4.00	1.63	1.50	3.50	2.00	#10	.22	2.57
SSUPB024-XS	1.500	4.00	3.25	1.750	.50	4.75	1.88	1.75	4.12	2.50	1/4	.28	3.94

**Type TWN-OPN and SSUTWNO**

**Pillow Blocks** (Dimensions in inches)

Part Number	Nom. Dia.	L2	J3	Wt. (lb)
TWN80PN-XS	.500	3.50	2.50	.40
SSUTWNO12-XS	.750	4.50	3.50	1.24
SSUTWNO16-XS	1.000	6.00	4.50	2.48
SSUTWNO20-XS	1.250	7.50	5.50	5.14
SSUTWNO24-XS	1.500	9.00	6.50	8.08

Housing Material: Aluminum Alloy Black Anodized

**Type SRA LinearRace Shaft Support Rail Assembly** (Dimensions in inches)

Part Number	Nom. Dia.	H1	H7	Br	K	X	G		Wt. (lb/ft)
							Bolt	Hole	
SRA8-XS	.500	1.125	.19	1.50	1.00	4	#8	.17	1.26
SRA12-XS	.750	1.500	.25	1.75	1.25	6	#10	.22	2.50
SRA16-XS	1.000	1.750	.25	2.13	1.50	6	1/4	.28	4.06
SRA20-XS	1.250	2.125	.31	2.50	1.88	6	5/16	.34	6.30
SRA24-XS	1.500	2.500	.38	3.00	2.25	8	5/16	.34	8.60

LinearRace Shaft Support Rail Material: Aluminum Alloy Black Anodized

Support rails are supplied in 24 inch lengths unless quoted otherwise. Maximum length of LinearRace Shaft Support Rail is 72 inches. If longer continuous one-piece LinearRace Shaft Support Rails are required, contact the Thomson Linear Guides Application Engineering department.

Y = distance from end of rail to the center of first mounting hole, Y1 = Y2 unless specified.



# Continuous Support 1PA

## Fully Supported, Highest Performance, Industry Standard Dimension Metric

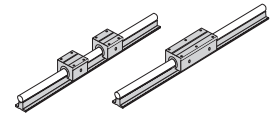

### Features

- Requires only one part number to specify the entire linear guide.
- Used as a load support, transport and guidance solution.
- Used in continuously supported applications when rigidity is required.

### Components

- 2 Super Smart Ball Bushing® open type pillow blocks or 1 Super Smart Ball Bushing open twin pillow blocks.
- 1 60 Case LinearRace shaft support rail assembly.

### Dimensions (Inch)

Single Continuously Supported Linear Guide with 2 Pillow Blocks

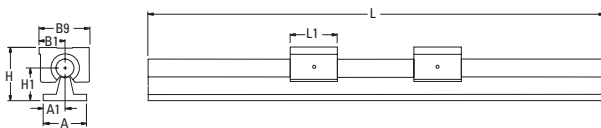

Single Continuously Supported Linear Guide with 1 Twin Pillow Block

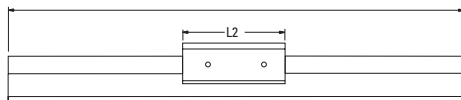

Type SSEPBO Open Type Super Smart Ball Bushing Pillow Blocks

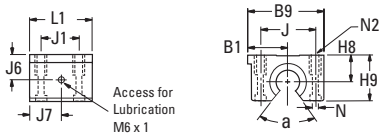

Type SSETWNO Open Type Super Smart Ball Bushing Twin Pillow Blocks

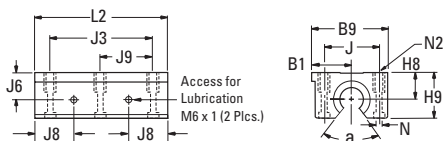

### Specifying this Thomson Linear Guide

1. Determine the proper linear guide for your load and life requirements.
2. Select the part number.
3. Add the letter "L" followed by the overall length in inches, as a suffix to the part number.

### Part Numbering System

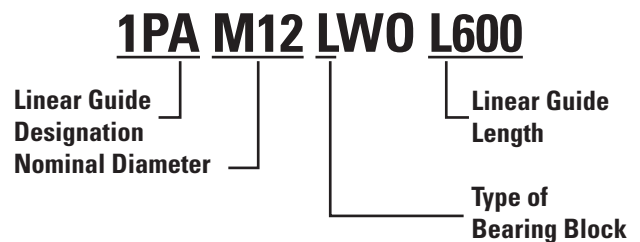

### Load Rating and Limit by Direction

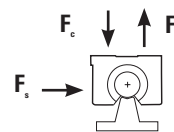

	Dynamic Load Rating	Load Limit
$F_c$	C	C
$F_t$	0.5C	0.5C
$F_s$	C	0.5C

Dynamic Load Rating: Load value used in life calculation.  
Load Limit: Maximum allowable load applied to bearing.

### Type SRA LinearRace Shaft Support Rail Assembly

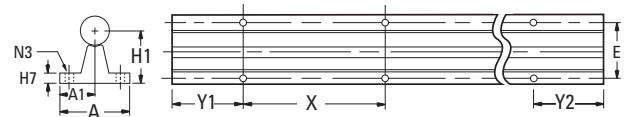

**Continuously Supported Linear Guide 1PA Single with 2 Pillow Blocks** (Dimensions in mm)

Part Number	Nominal Diameter	L1	H	H1	A	A1	B1	B9	Pillow Block	Shaft Support Rail Assembly
1PAM12LWO	12	39	46	28	43	21.5	21.5	43	SPPBOM12-XS <sup>†</sup>	SRAM12-XS
1PAM16LWO	16	43	52	30	48	24.0	26.5	53	SSEPBO16-XS	SRAM16-XS
1PAM20LWO	20	54	63	38	56	28.0	30.0	60	SSEPBO20-XS	SRAM20-XS
1PAM25LWO	25	67	72	42	60	30.0	39.0	78	SSEPBO25-XS	SRAM25-XS
1PAM30LWO	30	79	88	53	74	37.0	43.5	87	SSEPBO30-XS	SRAM30-XS
1PAM40LWO	40	91	105	60	78	39.0	54.0	108	SSEPBO40-XS	SRAM40-XS

**Continuously Supported Linear Guide 1PA Single with 1 Twin Pillow Block** (Dimensions in mm)

Part Number	Nominal Diameter	L2	H	H1	A	A1	B1	B9	Maximum Stroke Length	Pillow Block	Shaft Support Rail Assembly
1PAM12MWO	12	76	46	28	43	21.5	21.5	43	L-(76)	SPTWNOM12-XS <sup>†</sup>	SRAM12-XS
1PAM16MWO	16	84	52	30	48	24.0	26.5	53	L-(84)	SSETWNOM16-XS	SRAM16-XS
1PAM20MWO	20	104	63	38	56	28.0	30.0	60	L-(104)	SSETWNOM20-XS	SRAM20-XS
1PAM25MWO	25	130	72	42	60	30.0	39.0	78	L-(130)	SSETWNOM25-XS	SRAM25-XS
1PAM30MWO	30	152	88	53	74	37.0	43.5	87	L-(152)	SSETWNOM30-XS	SRAM30-XS
1PAM40MWO	40	176	105	60	78	39.0	54.0	108	L-(176)	SSETWNOM40-XS	SRAM40-XS

**Dynamic Load Capacity Matrix** (100 km travel)

Linear Guide Assembly Part Number	Dynamic Load Capacity (N) (Even Distribution)	Pillow Block Part Number	Pillow Block Dynamic Load Capacity (N)
1PAM12LWO	1500	SPPBOM12-XS	750
1PAM16LWO	4400	SSEPBO16-XS	2200
1PAM20LWO	8000	SSEPBO20-XS	4000
1PAM25LWO	13400	SSEPBO25-XS	6700
1PAM30LWO	16600	SSEPBO30-XS	8300
1PAM40LWO	27400	SSEPBO40-XS	13700

**Dynamic Load Capacity Matrix** (100 km travel)

Linear Guide Assembly Part Number	Dynamic Load Capacity (N) (Even Distribution)	Pillow Block Part Number	Pillow Block Dynamic Load Capacity (N)
1PAM12MWO	1220	SPTWNOM12-XS	1500
1PAM16MWO	4400	SSETWNOM16-XS	4400
1PAM20MWO	8000	SSETWNOM20-XS	8000
1PAM25MWO	13400	SSETWNOM25-XS	13400
1PAM30MWO	16600	SSETWNOM30-XS	16600
1PAM40MWO	27400	SSETWNOM40-XS	27400

† Super Ball Bushing Bearings are used in 12 mm size pillow blocks.

**Replacement Component Dimensions**

**Type SSEPBO Pillow Blocks** (Dimensions in mm)

Part Number	Nom. Dia.	L1	H8	H9	B1	B9	J6	J7	J	J1	N		a	Mass (kg)
											Di.	M5		
SPPBOM12-XS	12	39	18	28	215	43	16.7	19.5	32	23	43	M5	66	0.11
SSEPBO16-XS	16	43	22	35	265	53	22.0	21.5	40	26	53	M6	66	0.17
SSEPBO20-XS	20	54	25	41	300	60	25.0	27.0	45	32	66	M8	60	0.30
SSEPBO25-XS	25	67	30	50	390	78	31.5	33.5	46	40	84	M10	60	0.57
SSEPBO30-XS	30	79	35	60	435	87	33.0	39.5	68	45	84	M10	60	0.87
SSEPBO40-XS	40	91	45	77	540	108	43.5	45.5	86	58	105	M12	60	1.62

Housing Material: Aluminum Alloy Grey Anodized.

**Type SSETWNO Pillow Blocks** (Dim. in mm)

Part Number	Nom. Dia.	L2	J3	J8	J9	Mass (kg)
SSETWNOM16-XS	16	84	64	21.5	32	0.34
SSETWNOM20-XS	20	104	76	27.0	38	0.63
SSETWNOM25-XS	25	130	94	33.6	47	1.18
SSETWNOM30-XS	30	152	106	39.5	53	1.70
SSETWNOM40-XS	40	176	124	45.5	62	3.18

Housing Material: Aluminum Alloy Grey Anodized

**Type SRA LinearRace Shaft Support Rail Assembly** (Dimensions in mm)

Part Number	Nom. Dia.	H1	H7	A	A1	E	X	N3	Mass (kg/m)
								Di.	
SRAM12-XS	12	28	5	43	21.5	29	75	4.5	4.1
SRAM16-XS	16	30	5	48	24.0	33	100	5.5	6.2
SRAM20-XS	20	38	6	56	28.0	37	100	6.6	9.5
SRAM25-XS	25	42	6	60	30.0	42	120	6.6	13.7
SRAM30-XS	30	53	8	74	37.0	51	150	8.6	20.0
SRAM40-XS	40	60	8	78	39.0	55	200	8.6	32.5

LinearRace Shaft Support Rail Material: Aluminum Alloy Grey Anodized

Support rails are supplied in 600mm lengths unless quoted otherwise. Maximum length of LinearRace Shaft Support Rail is 600mm. If longer continuous one-piece LinearRace Shaft Support Rails are required, contact the Thomson Linear Guides Application Engineering department.

Y = distance from end of rail to the center of first mounting hole, Y1 = Y2 unless specified.



## FluoroNyliner<sup>®</sup> Linear Guides

**Corrosion resistant, smooth, quiet,  
industry standard envelope**

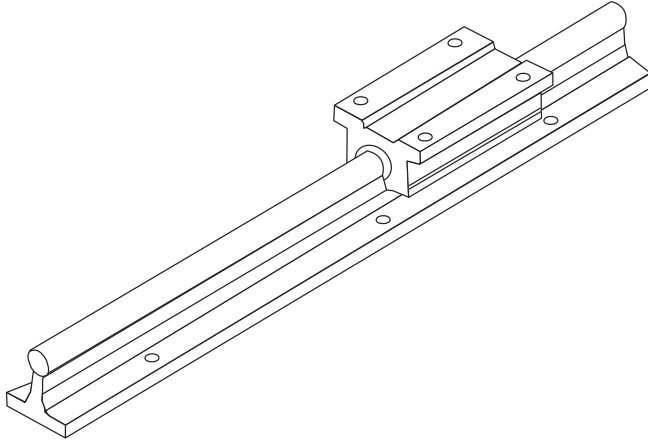

### **FluoroNyliner Linear Guides Offer:**

- Thomson FluoroNyliner Bushing Bearings that are made from the most advanced polymer components to achieve maximum performance levels
- Contamination resistance. The FluoroNyliner linear guides are practically immune to adverse environments, such as water washdown conditions and magnetic interference.
- Self-aligning pillow blocks for ease of use.
- Increased bearing load capacities (or 'PV' ratings) and obtainable travel life when used with Thomson 60 Case<sup>®</sup> LinearRace<sup>®</sup> shaft, and when compared to competitive assemblies.
- Specification conformance with FDA and non-lubricated applications.
- Use in linear and rotary motion applications.
- Operates in temperatures from -400 to 550°F (-240 to 287°C).

# FluoroNyliner 1VA

## Corrosive/Contaminated Environments Inch

### Features

- Requires only one part number to specify the entire linear guide.
- Used as a load support, transport and guidance solution.
- Used in continuously supported applications when rigidity is required.

### Components

- 2 self-aligning FluoroNyliner Bushing Bearing open pillow blocks or
- 1 self-aligning FluoroNyliner Bushing Bearing open twin pillow block
- 1 stainless steel 60 Case LinearRace shaft support rail assembly

### Dimensions (Inch)

Single Continuously Supported Linear Guide with 2 Pillow Blocks

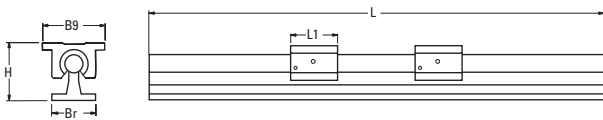

Single Continuously Supported System with 1 Twin Pillow Block

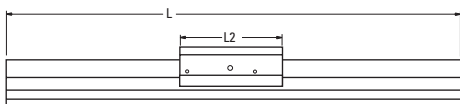

FluoroNyliner Linear Guide Pillow Block Dimensions

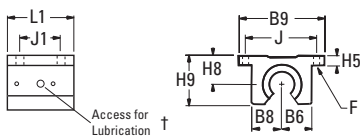

FluoroNyliner Linear Guide Twin Pillow Block Dimensions

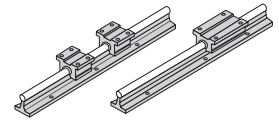
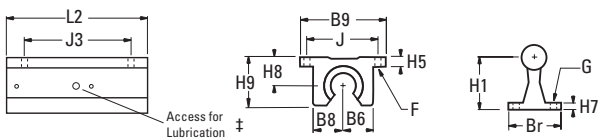

### Specifying this Thomson Linear Guide

1. Determine the proper linear guide for your load and life requirements.
2. Select the part number.
3. Add the letter "L" followed by the overall length in inches as a suffix to the part number.

### Part Numbering System

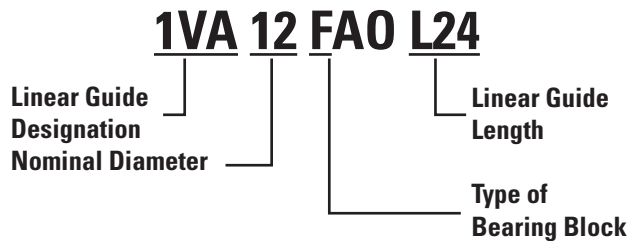

### Load Rating and Limit by Direction

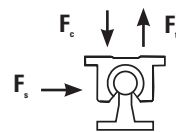

	Dynamic Load Rating	Load Limit
$F_c$	C	C
$F_t$	0.5C	0.5C
$F_s$	C	0.5C

Dynamic Load Rating: PV value used in life calculation.  
Load Limit: Maximum allowable PV applied to bearing.

### Type SRA LinearRace Shaft Support Rail Assembly

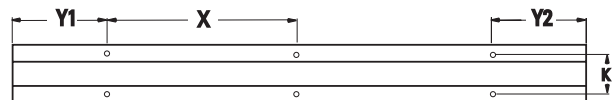



### FluoroNyliner® Linear Guide 1VA Single Continuously Supported with 2 Pillow Blocks (Dimensions in inches)

Part Number	Nominal Diameter	L1	H	Br	B9	Pillow Block	Shaft Support Rail Assembly
1VA08FAO	.500	1.50	1.812	1.50	2.00	FNYBUPB008A-XS	SRA8-SS-XS
1VA12FAO	.750	1.88	2.437	1.75	2.75	FNYBUPB012A-XS	SRA12-SS-XS
1VA16FAO	1.000	2.63	2.937	2.13	3.25	FNYBUPB016A-XS	SRA16-SS-XS
1VA20FAO	1.250	3.38	3.625	2.50	4.00	FNYBUPB020A-XS	SRA20-SS-XS
1VA24FAO	1.500	3.75	4.250	3.00	4.75	FNYBUPB024A-XS	SRA24-SS-XS

### FluoroNyliner Linear Guide 1VA Single Continuously Supported with 1 Twin Pillow Block (Dimensions in inches)

Part Number	Nominal Diameter	L2	H	Br	B9	Maximum Stroke Length	Pillow Block	Shaft Support Rail Assembly
1VA08HAO	.50	3.5	1.812	1.50	2.00	L-(3.5)	FNYBUTWNO08A-XS	SRA8-SS-XS
1VA12HAO	.75	4.5	2.437	1.75	2.75	L-(4.5)	FNYBUTWNO12A-XS	SRA12-SS-XS
1VA16HAO	1.00	6.0	2.937	2.13	3.25	L-(6.0)	FNYBUTWNO16A-XS	SRA16-SS-XS
1VA20HAO	1.25	7.5	3.625	2.50	4.00	L-(7.5)	FNYBUTWNO20A-XS	SRA20-SS-XS
1VA24HAO	1.50	9.0	4.250	3.00	4.75	L-(9.0)	FNYBUTWNO24A-XS	SRA24-SS-XS

### Maximum Operating Parameters per Bearing

Characteristic	Limit
Linear Temperature Range	-240°C to 288°C (-400°F to 550°F)
Velocity, dry	42.7 m/min. Continuous
Velocity, dry	122 m/min. Intermittent
Velocity, lubricated	122 m/min. Continuous
Pressure	10.35 MPa
PV	21 MPa/m/min

## Replacement Component Dimensions

#### Self-Aligning Pillow Blocks (Dimensions in inches)

Part Number	Nom. Dia.	L1	H9	H8	H5	B9	B8	B7	J	J1	F		Wt. (lb)	Part Number	Nom. Dia.	L2	J3	Wt. (lb)
											Bolt	Hole						
FNYBUPB008A-XS	.500	1.69	1.25	.687	.25	2.00	.75	.69	1.69	1.00	#6	.16	.20	FNYBUTWNO08A-XS	.500	3.50	2.50	.40
FNYBUPB012A-XS	.750	2.06	1.75	.937	.31	2.75	1.00	.94	2.38	1.25	#8	.19	.51	FNYBUTWNO12A-XS	.750	4.50	3.50	1.02
FNYBUPB016A-XS	1.000	2.81	2.19	1.187	.38	3.25	1.25	1.19	2.88	1.75	#10	.22	1.03	FNYBUTWNO16A-XS	1.000	6.00	4.50	2.06
FNYBUPB020A-XS	1.250	3.63	2.81	1.500	.43	4.00	1.63	1.50	3.50	2.00	#10	.22	2.15	FNYBUTWNO20A-XS	1.250	7.50	5.50	4.30
FNYBUPB024A-XS	1.500	4.00	3.25	1.750	.50	4.75	1.88	1.75	4.12	2.50	1/4	.28	3.29	FNYBUTWNO24A-XS	1.500	9.00	6.50	6.88

Housing Material: Aluminum Alloy Black Anodized

Housing Material: Aluminum Alloy Black Anodized

Performance Note: For detailed explanations of FluoroNyliner Linear Guide Dynamic and Static Load Capacities, Frictional Characteristics, Wear Rates, Speeds, and Life Expectancy please contact the Thomson Linear Guides Applications Engineering department.

Product Note: FluoroNyliner linear guides are shipped free of all lubricants. It is the responsibility of the product user to determine lubricant compatibility with the FluoroNyliner bearing material.

Product Options: FluoroNyliner linear guides are available with various inner race materials and platings to accommodate different environments.

### Type SRA LinearRace Shaft Support Rail Assembly (Dimensions in inches)

Part Number	Nom. Dia.	H1	H7	Br	K	X	G		Wt. (lb/ft)
							Bolt	Hole	
SRA8-XS	.500	1.125	.19	1.50	1.00	4	#8	.17	1.26
SRA12-XS	.750	1.500	.25	1.75	1.25	6	#10	.22	2.50
SRA16-XS	1.000	1.750	.25	2.13	1.50	6	1/4	.28	4.06
SRA20-XS	1.250	2.125	.31	2.50	1.88	6	5/16	.34	6.30
SRA24-XS	1.500	2.500	.38	3.00	2.25	8	5/16	.34	8.60

LinearRace® Shaft Support Rail Material: Aluminum Alloy Black Anodized

Support rails are supplied in 24 inch lengths unless quoted otherwise. Maximum length of LinearRace Shaft Support Rail is 72 inches. If longer continuous one-piece LinearRace Shaft Support Rails are required, contact the Thomson Linear Guide Application Engineering department.

Y = distance from end of rail to the center of first mounting hole, Y1 = Y2 unless specified.

## Side-Mounted Linear Ball Guides

**Low profile, high loads in all directions,  
easy to install**

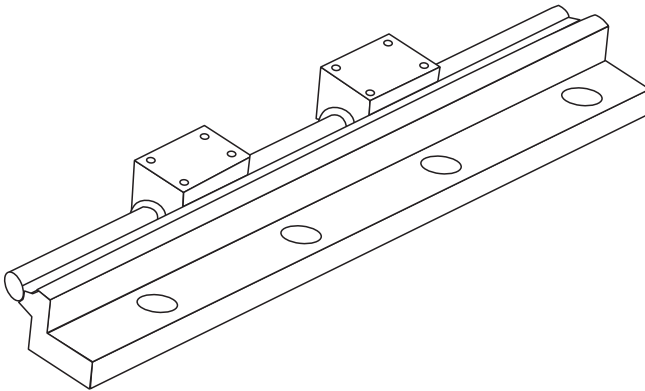

### Side-Mounted Linear Ball Guides Offer:

- Increased life within the same envelope. RoundRail linear guides feature the patented Super Smart Ball Bushing® Bearings for up to 216X the life or 6X the load capacity of conventional bearings.
- Cost savings: save time and money preparing your mounting surfaces before bolting down RoundRail linear guides.
- Side-mounted geometry for increased mounting flexibility.
- Superior performance. Continuously supported for maximum (down- and side-) load applications without concerns for shaft deflection.
- The RoundRail Advantage. The inherent self-aligning-in-all-directions design of the Super Smart Ball Bushing Bearing allows for ultra-smooth travel when mounted to wider-toleranced, prepared surfaces.
- Unlimited travel lengths without concerns for machined reference edges or butt joint alignment.
- The Super Smart Ball Bushing Bearing... the most technologically advanced and robust linear bearing in the world.
- Corrosion-resistant versions for maximum performance in harsh environments.



# Side-Mounted 1DA

## Side-Mounted for Low-Profile Inch

### Features

- Continuously supported design increases rigidity and provides for unlimited linear guide travel lengths.
- Versatile side support rail assembly geometry for optimizing mounting ability.
- Side-mounted design provides an increase in pull-off load capacity.

### Components

- 2 Super Smart Ball Bushing® modified open type pillow blocks or 1 Super Smart Ball Bushing modified open type twin pillow block.
- 1 60 Case LinearRace shaft side mounted support rail assembly

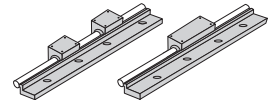

### Specifying this Thomson Linear Guide

1. Determine the proper linear guide for your load and life requirements.
2. Select the part number.
3. Add the letter "L" followed by the overall length in inches as a suffix to the part number.

### Part Numbering System

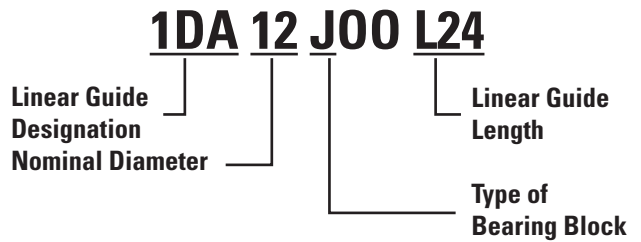

### Dimensions (Inch)

#### Single Side Mounted Linear Guide with 2 Pillow Blocks

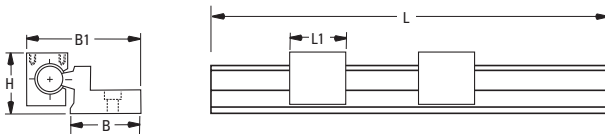

#### Single Side-Mounted Linear Guide with 1 Twin Pillow Block

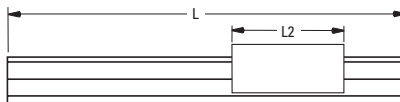

#### Type SSUPBO-MOD and SPB-OPN-MOD Open Type Pillow Blocks

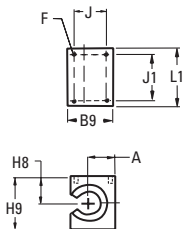

#### Type SSUTWNO-MOD and TWN-OPN-MOD Pillow Blocks

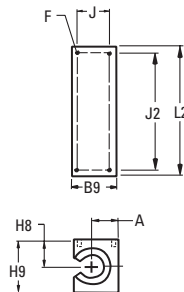

### Load Rating and Limit by Direction

	Dynamic Load Rating	Load Limit
$F_c$	C	C
$F_t$	0.5C	0.5C
$F_s$	C	0.5C

Dynamic Load Rating: Load value used in life calculation.  
Load Limit: Maximum allowable load applied to bearing.

### Type SSRA Side-Mounted LinearRace® Shaft Support Rail Assembly

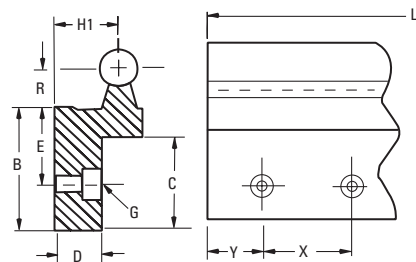

**Side-Mounted Linear Guide 1DA Single Side-Mounted with 2 Pillow Blocks** (Dimensions in inches)

Part Number	Nominal Diameter	H	B	B1	L1	Pillow Block	Shaft Support Rail Assembly
1DA08J00	.500	1.562	1.44	2.61	1.50	SPB80PN-MOD	SSRA08
1DA12J00	.750	2.062	1.94	3.55	1.88	SSUPB012-MOD	SSRA12
1DA16J00	1.000	2.562	2.44	4.49	2.63	SSUPB016-MOD	SSRA16

**Side-Mounted Linear Guide 1DA Single Side-Mounted with 1 Twin Pillow Block** (Dimensions in inches)

Part Number	Nominal Diameter	H	B	B1	L2	Maximum Stroke Length	Pillow Block	Shaft Support Rail Assembly
1DA08K00	.50	1.562	1.44	2.61	3.5	L-(3.5)	TWN80PN-MOD	SSRA08
1DA12K00	.75	2.062	1.94	3.55	4.5	L-(4.5)	SSUTWNO12-MOD	SSRA12
1DA16K00	1.00	2.562	2.44	4.49	6.0	L-(6.0)	SSUTWNO16-MOD	SSRA16

**Mounting Configurations**

The following mounting configurations depict ideas for combining the side-mounted continuously supported linear guides into your linear motion application. If you need further information, contact the Thomson Application Engineering Department.

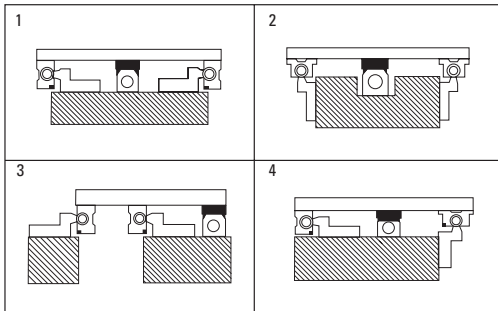

Pillow blocks shown are the standard SSUPBO or SPB-OPN style. To order System 1DA with standard pillow blocks, order the side-mounted shaft rail assembly (SSRA) and the SSUPBO or SPB-OPN separately.

**Dynamic Load Capacity Matrix** (4 million inches travel)

Linear Guide Assembly Part Number	Dynamic Load Capacity (N) (Even Distribution)	Pillow Block Part Number	Pillow Block Dynamic Load Capacity (N)
1DA08J00	240	SPB80PN-MOD	120
1DA12J00	1600	SSUPB012-MOD	800
1DA16J00	2700	SSUPB016-MOD	1350
1DA08K00	240	TWN80PN-MOD	240
1DA12K00	1600	SSUTWNO12-MOD	1600
1DA16K00	2700	SSUTWNO16-MOD	2700

† Super Ball Bushing Bearings are used in .500 inch size pillow blocks.

**Replacement Component Dimensions**

**Type SPBOPN-MOD and SSUPBO-MOD Pillow Block** (Dimensions in inches)

Part Number	Nom. Dia.	H8	H9	A	B9	L1	J	J1	F	Wt. (lb)
SPB80PN-MOD	.500	.687	1.44	.67	1.12	1.50	.812	1.250	#8-32	.18
SSUPB012-MOD	.750	.937	1.94	.92	1.56	1.88	1.187	1.562	#10-32	.45
SSUPB016-MOD	1.000	1.187	2.44	1.17	2.00	2.63	1.438	2.250	1/4-20	.98

Housing Material: Aluminum Alloy Black Anodized

**Type TWNOPN-MOD and SSUTWNO-MOD Pillow Blocks** (Dimensions in inches)

Part Number	Nom. Dia.	L2	J2	Wt. (lb)
TWN80PN-MOD	.500	3.5	3.00	.39
SSUTWNO12-MOD	.750	4.5	4.00	1.00
SSUTWNO16-MOD	1.000	6.0	5.25	2.11

Housing Material: Aluminum Alloy Black Anodized

**Type SSRA LinearRace Shaft Support Rail Assembly** (Dimensions in inches)

Part Number	Nom. Dia.	H1	B	R	E	D	C	X	G		Wt. (lb/ft)
									Bolt	Hole	
SSRA08	.500	.875	1.44	.500	1.00	.49	1.06	4	1/4	.28	2.05
SSRA12	.750	1.125	1.94	.688	1.31	.75	1.44	6	5/16	.34	4.00
SSRA16	1.000	1.375	2.44	.875	1.63	.88	1.81	6	3/8	.41	6.25

(1) For standard lengths LinearRace Shaft Support Rail Material: Aluminum Black Anodized  
Support rails are supplied in 24 inch lengths unless quoted otherwise. Maximum length of LinearRace Shaft Support Rail is 72 inches. If longer continuous one-piece LinearRace Shaft Support Rails are required, contact the Thomson Linear Guides Application Engineering department.  
Y = distance from end of rail to the center of first mounting hole, Y1 = Y2 unless specified.



## Dual Shaft

**Low profile, high loads in all directions, easy to install**

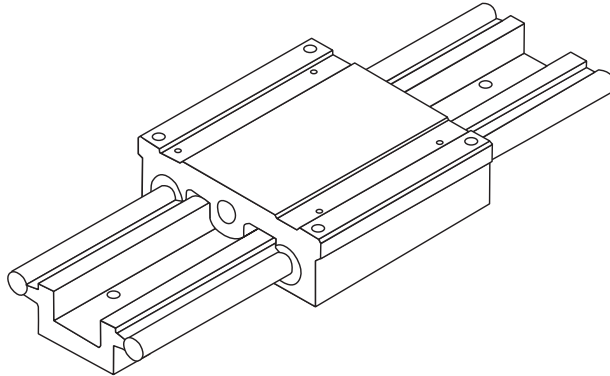

### Dual Shafts Offer:

- This performance proven linear guide has an extremely low profile and features external rails with maximum bearing spacing. This provides the user with high pitch, yaw and roll moment capability. The load capacity is the same when mounted in the inverted position.
- Corrosion-resistant options are also available for demanding environmental conditions. These include chrome-plated or stainless steel shafting and corrosion-resistant bearings.
- The inherent, self-aligning design of the Super Smart Ball Bushing® Bearings allow for more deviation in the flatness of the mounting surface. This can dramatically reduce the installed cost of the linear guide.
- The base extrusion has a reference edge for registration in your machine. Unlimited travel lengths can be realized by combining base and shaft segments. The shafts and bases are staggered to allow keying of the subsequent stage.

# Dual Shaft Rail 2DA with Integrated Carriage Unpack and Install Inch

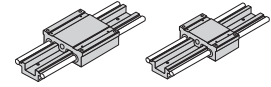

### Features

- Used in continuously supported applications when rigidity is required.
- Adaptable to any drive system.
- Pre-aligned and pre-assembled for immediate installation and use.
- Designed for medium to heavy loads.

### Components

- 1 Dual LinearRace® shaft rail assembly
- 1 integrated carriage with 4 open type Super Smart Ball Bushing Bearings

### Specifying this Thomson Linear Guide

1. Determine the proper linear guide for your load and life requirements.
2. Select the part number.
3. Add the letter "L" followed by the overall length in inches as a suffix to the part number.

### Part Numbering System

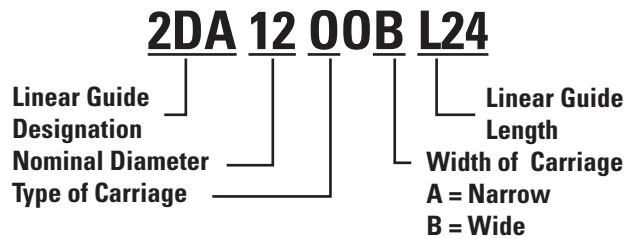

### Dimensions (Inch)

2DA XX 00B  
Rail Cross Section

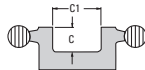

Dual Shaft Rail Linear Guide with Integrated Full Length Carriage

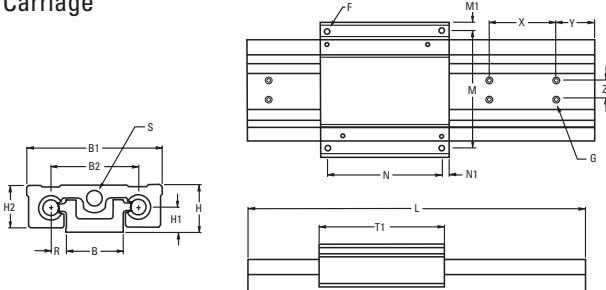

### Load Rating and Limit by Direction

	Dynamic Load Rating	Load Limit
$F_c$	C	0.5C
$F_t$	C	0.5C
$F_s$	0.5C	0.5C

Dynamic Load Rating: load value used in life calculation.  
Load Limit: Maximum allowable load applied to bearing.

2DA XX 00A  
Rail Cross Section

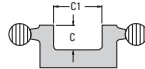

Dual Shaft Rail Linear Guide with Integrated Short Length Carriage

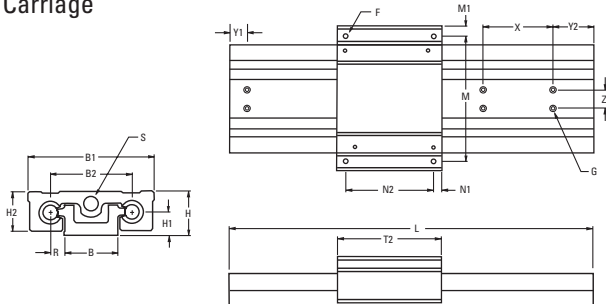

### Load Rating and Limit by Direction

	Dynamic Load Rating	Load Limit
$F_c$	C	0.5C
$F_t$	C	0.5C
$F_s$	0.5C	0.5C

Dynamic Load Rating: load value used in life calculation.  
Load Limit: Maximum allowable load applied to bearing.



### Dual Shaft Rail Linear Guide 2DA with Integrated Carriage (Dimensions in inches)

Part Number	Nominal Diameter	T1	H	H1	H2	B	R	B1	B2	C	C1
2DA0800B	.500	4.5	1.625	.875	1.43	2.00	.500	4.6	3.0	.64	1.25
2DA1200B	.750	6.0	2.125	1.125	1.93	2.63	.688	6.1	4.0	.75	1.662
2DA1600B	1.000	7.5	2.625	1.375	2.44	3.25	.875	7.6	5.0	.99	2.00

### Dual Shaft Rail Linear Guide 2DA with Integrated Carriage (Dimensions in inches)

Part Number	N	N1	M	M1	X	Z	S As Extruded	F	G		Maximum Stroke Length	Carriage	Dual Shaft Rail Assembly
									Bolt	Hole			
2DA0800B	4.00	.25	4.00	.30	4.0	.75	.50	#10-32	1/4	.28	L-(4.5)	DSRC08SB	DSRA08
2DA1200B	5.25	.37	5.25	.42	6.0	1.0	.70	1/4-20	5/16	.34	L-(6.0)	DSRC12SB	DSRA12
2DA1600B	6.75	.37	6.75	.42	6.0	1.25	.90	5/16-18	3/8	.41	L-(7.5)	DSRC16SB	DSRA16

Support rails are supplied in 24 inch lengths unless quoted otherwise.

Dual Shaft Rail Support Material: Black Anodized Aluminum Alloy

Maximum continuous length of support rails is 72". If longer continuous shaft support rails are required, please contact the Thomson Linear Guides Application Engineering department.

Y = distance from end of rail to the center of first mounting hole, Y1 = Y2 unless specified.

### Dynamic Load Capacity Matrix (4 million inches travel)

Linear Guide Assembly Part Number	Dynamic Load Capacity (lb.) (Even Distribution)	Dynamic Roll Moment (in-lb.)
2DA0800B	480	720
2DA1200B	3200	6400
2DA1600B	5400	13500

Note: Above load ratings used for life calculations. Load limit of assembly 50%.

### Dual Shaft Rail Linear Guide 2DA with Integrated Carriage (Dimensions in inches)

Part Number	Nominal Diameter	T2	H	H1	H2	B	R	B1	B2	C	C1
2DA0800A	.500	3.5	1.625	.875	1.43	2.00	.500	4.6	3.0	.64	1.25
2DA1200A	.750	4.5	2.125	1.125	1.93	2.63	.688	6.1	4.0	.75	1.662
2DA1600A	1.000	6.0	2.625	1.375	2.44	3.25	.875	7.6	5.0	.99	2.00

### Dual Shaft Rail Linear Guide 2DA with Integrated Carriage (Dimensions in inches)

Part Number	N	N2	M	M1	X	Z	S As Extruded	F	G		Maximum Stroke Length	Carriage	Dual Shaft Rail Assembly
									Bolt	Hole			
2DA0800A	.25	3.00	4.00	.30	4.0	.75	.50	#10-32	1/4	.28	L-(3.5)	DSRC08SA	DSRA08
2DA1200A	.37	3.75	5.25	.42	6.0	1.0	.70	1/4-20	5/16	.34	L-(4.5)	DSRC12SA	DSRA12
2DA1600A	.37	5.25	6.75	.42	6.0	1.25	.90	5/16-18	3/8	.41	L-(6.0)	DSRC16SA	DSRA16

Support rails are supplied in 24 inch lengths unless quoted otherwise.

Dual Shaft Rail Support Material: Black Anodized Aluminum Alloy

Maximum continuous length of support rails is 72". If longer continuous shaft support rails are required, please contact the Thomson Linear Guides Application Engineering department.

Y = distance from end of rail to the center of first mounting hole, Y1 = Y2 unless specified.

† Super Ball Bushing Bearings are used in 500 inch size carriages.

### Dynamic Load Capacity Matrix (4 million inches travel)

Linear Guide Assembly Part Number	Dynamic Load Capacity (lb.) (Even Distribution)	Dynamic Roll Moment (in-lb.)
2DA0800A	480	720
2DA1200A	3200	6400
2DA1600A	5400	13500

Note: Above load ratings used for life calculations. Load limit of assembly 50%.

## Twin Shaft Web

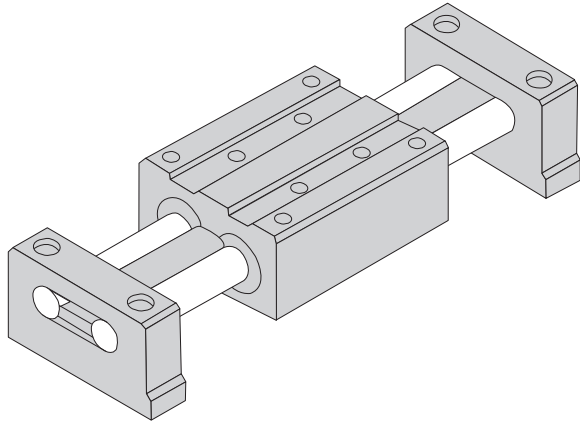

**High roll moment torque resistance,  
high rigidity, smooth, easy to install**

### **Twin Shaft Web Linear Ball Guides Offer:**

- Twin shaft web design for high roll moment capacity, high rigidity and ultra smooth travel.
- Pre-aligned shafts, end supported for gantry style or 'bridge' applications.
- Available in horizontal and vertical orientations for increased mounting flexibility.
- End supported for quicker and easy installation.
- The Super Smart Ball Bushing® Bearing... the most technologically advanced and most robust linear bearing in the world.
- The RoundRail Advantage. The inherent, self-aligning-in-all-directions design of the Super Smart Ball Bushing Bearing allows for ultra-smooth travel when mounted to wider-toleranced prepared surfaces.
- Cost savings: save time and money preparing your mounting surfaces before bolting down RoundRail linear guides.
- Corrosion-resistant versions for maximum performance in harsh environments.



# Twin Shaft Web 2CA with Universal Carriage Unpack and Install Inch

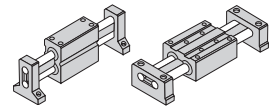

## Features

- Used when spanning or bridging a gap.
- Double LinearRace® shaft and welded integral web design maximizes torque and dramatically improves deflection characteristics.
- Pre-aligned for quick and easy installation.
- Designed to move medium loads with virtually frictionless travel.

## Components

- Universal integrated carriage with four open-type Super Smart Ball Bushing Bearings.
- Twin welded 60 Case® LinearRace shafts with integral web.
- 2 vertical or horizontal double end supports.

## Specifying this Thomson Linear Guide

1. Determine the proper linear guide for your load and life requirements.
2. Select the part number.
3. Add the letter "L" followed by the overall length in inches as a suffix to the part number.

## Part Numbering System

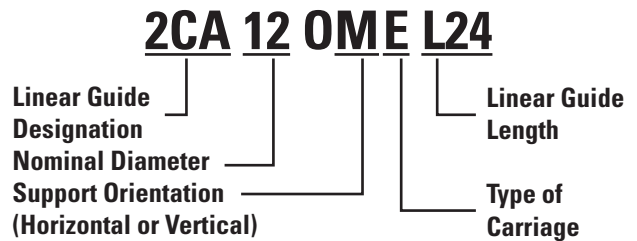

## Dimensions (Inch)

### Twin Shaft Web Linear Guide with Universal Carriage (Vertical Configuration)

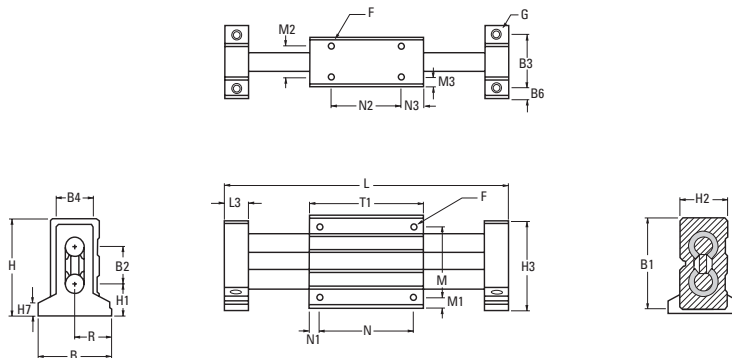

### Twin Shaft Web Linear Guide with Universal Carriage (Horizontal Configuration)

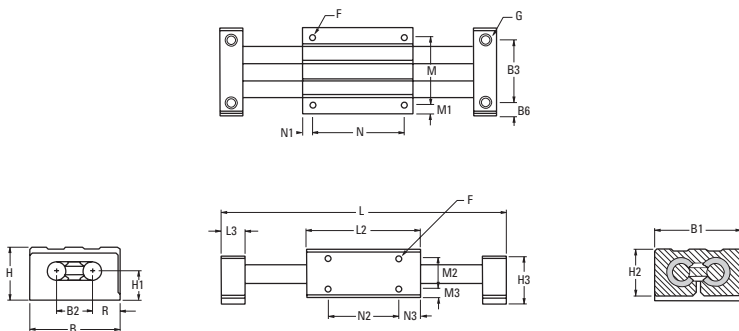

**Twin Shaft Web Linear Guide End Supported 2CA (Vertical Configuration)** (Dimensions in inches)

Part Number	Nominal Diameter	L3	H	H1	H3	H7	B	R	B2	B3	B4	B6	T1	N
2CA080KE	.500	.63	2.750	.875	2.56	.38	2.25	1.125	1.13	1.63	1.12	.31	3.5	3.00
2CA120KE	.750	.75	3.625	1.125	3.44	.56	3.00	1.500	1.50	2.25	1.63	.38	4.5	4.00
2CA160KE	1.000	1.00	4.625	1.375	4.50	.75	4.00	2.00	2.00	3.00	2.25	.50	6.0	5.25

**Twin Shaft Web Linear Guide End Supported 2CA (Vertical Configuration)** (Dimensions in inches)

Part Number	N1	N2	N3	H2	B1	M	M1	M2	M3	F	G		Maximum Stroke Length	Dual Shaft Rail Assembly
											Bolt	Hole		
2CA080KE	.25	2.5	.50	1.5	2.62	2.00	.31	.88	.31	#10-32	#10	.22	L-(4.75)	TSWA08
2CA120KE	.25	3.5	.50	2.0	3.50	2.87	.31	1.38	.31	1/4-20	1/4	.28	L-(6.00)	TSWA12
2CA160KE	.38	4.5	.75	2.5	4.50	3.62	.44	1.62	.44	5/16-18	5/16	.34	L-(8.00)	TSWA16

Maximum Length is 72 inches.

**2CA (Vertical Config.) Carriage and End Support Part No.**

Linear Guide Part Number	Carriage Part Number	End Support Part Number
2CA080KE	WC08	WSB08V
2CA120KE	WC12	WSB12V
2CA160KE	WC16	WSB16V

**Dynamic Load Capacity Matrix** (4 million inches travel)

Linear Guide Assembly Part Number	Dynamic Load Capacity (lb.) (Even Distribution)	Pillow Block Dynamic Load Capacity (lb.)
2CA080KE	290	165
2CA120KE	1800	1350
2CA160KE	3000	3000

Shaft Deflection Note:  
Load limit may be below the dynamic load rating due to shaft deflection.  
Bearings can accommodate up to 1/2° deflection.  
See Engineering section (page 269) for Deflection calculations.

† Super Ball Bushing Bearings are used in .500 inch size carriages.

**Twin Shaft Web Linear Guide End Supported 2CA (Horizontal Configuration)** (Dimensions in inches)

Part Number	Nominal Diameter	L3	H	H1	H3	B	R	B2	B3	B6	T1	N
2CA080ME	.500	.63	1.625	.875	1.50	2.62	.75	1.13	2.00	.31	3.5	3.00
2CA120ME	.750	.75	2.125	1.125	2.00	3.50	1.00	1.50	2.75	.37	4.5	4.00
2CA160ME	1.000	1.00	2.625	1.375	2.50	4.50	1.25	2.00	3.62	.50	6.0	5.25

**Twin Shaft Web Linear Guide End Supported 2CA (Horizontal Configuration)** (Dimensions in inches)

Part Number	N1	N2	N3	H2	B1	M	M1	M2	M3	F	G		Maximum Stroke Length	Dual Shaft Rail Assembly
											Bolt	Hole		
2CA080ME	.25	2.5	.50	1.5	2.62	2.00	.31	.88	.31	#10-32	#10	.22	L-(4.75)	TSWA08
2CA120ME	.25	3.5	.50	2.0	3.50	2.87	.31	1.38	.31	1/4-20	1/4	.28	L-(6.00)	TSWA12
2CA160ME	.38	4.5	.75	2.5	4.50	3.62	.44	1.62	.44	5/16-18	5/16	.34	L-(8.00)	TSWA16

Maximum Length is 72 inches.

**2CA (Horizontal Config.) Carriage and End Support Part No.**

Linear Guide Part Number	Carriage Part Number	End Support Part Number
2CA080ME	WC08	WSB08H
2CA120ME	WC12	WSB12H
2CA160ME	WC16	WSB16H

**Dynamic Load Capacity Matrix** (4 million inches travel)

Linear Guide Assembly Part Number	Dynamic Load Capacity (lb.) (Even Distribution)	Pillow Block Dynamic Load Capacity (lb.)
2CA080ME	290	165
2CA120ME	1800	1350
2CA160ME	3000	3000

Shaft Deflection Note:  
Load limit may be below the dynamic load rating due to shaft deflection.  
Bearings can accommodate up to 1/2° deflection.  
See Engineering section (page 269) for Deflection calculations.

† Super Ball Bushing Bearings are used in .500 inch size carriages.



## Accessories

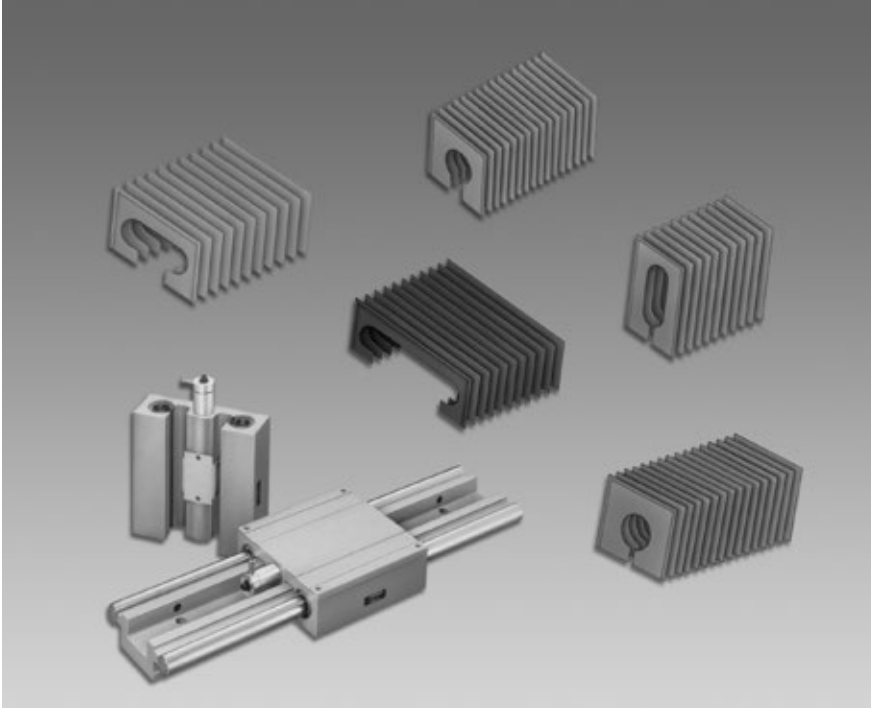

**We offer a variety of accessories for the Thomson line of RoundRail linear guides.**

- \* Protective bellows are available on select models for applications where protection of the RoundRail guides and carriage bearings are required within harsh or dirty operating environments.
- \* Some linear guide models are available with manually operated locking brakes for vertical applications and operations requiring unlimited carriage position alignment in the available range of stroke.
- \* We encourage you to inquire about linear guide accessories not shown here or any custom application needs that you may have.

**For a full list of available accessories, including Table Tops, visit [www.thomsonlinear.com](http://www.thomsonlinear.com).**

# Collapsible Bellows

Bellows will reduce available stroke length of slide by approximately 28%.  
Bellows P/N should be succeeded by a length when ordering.

- Bellows Materials:
- Polyester Cover
  - PVC Stiffeners

## BEL-1B (For 1BA) Moveable Protective Bellows (Dimensions in inches)

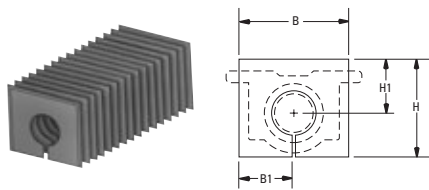

Part Number	Nominal Shaft Diameter	H	H1	B	CR
BEL1B04	1/4	1.187	.906	1.182	.163
BEL1B06	3/8	1.312	.968	1.937	.108
BEL1B08	1/2	1.687	1.156	2.062	.160
BEL1B12	3/4	2.000	1.156	2.312	.108
BEL1B16	1	2.375	1.281	2.625	.163
BEL1B24	1 1/2	3.062	1.531	3.125	.108

Each moveable bellows comes with 1 section of bellows and 2 pairs of Velcro® fasteners.

## BEL-1C (For 1CA) Moveable Protective Bellows (Dimensions in inches)

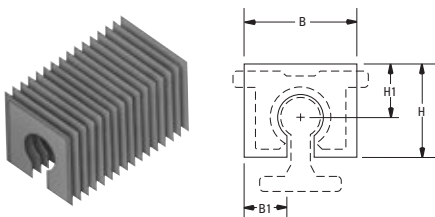

Part Number	Nominal Shaft Diameter	H	H1	B	CR
BEL1C08	1/2	1.375	.968	2.062	.088
BEL1C12	3/4	1.812	1.062	2.312	.120
BEL1C16	1	2.375	1.218	2.625	.088
BEL1C24	1 1/2	3.125	1.531	3.125	.088

Each moveable bellows comes with 1 section of bellows and 2 pairs of Velcro fasteners.

## BEL-2D (For QuickSlide System 2DA) Dual Shaft Rail Bellows (Dimensions in inches)

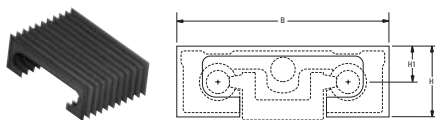

Part Number	Nominal Shaft Diameter	H	H1	B
BEL2DA08	1/2	1.50	.85	4.60
BEL2DB08	1/2	1.89	1.34	5.13
BEL2D12	3/4	2.406	1.437	6.00
BEL2D16	1	2.875	1.687	7.50

Each moveable bellows comes with 1 section of bellows and 2 mounting brackets and mounting screws (1/2" comes with Velcro fastener). Appropriate arrangements for affixing the bellows at each end of the QuickSlide 2DA System are required.

## BEL-2C-H (For Horizontal Twin Shaft Web QuickSlide System 2CA) Moveable Protective Bellows (Dimensions in inches)

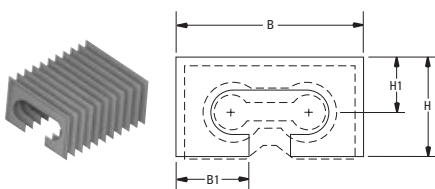

Part Number	Nominal Shaft Diameter	H	H1	B	CR
BEL2C08H	1/2	1.688	1.031	3.250	.108
BEL2C12H	3/4	2.062	1.156	3.812	.108
BEL2C16H	1	2.437	1.281	4.62	.108

Each moveable bellows comes with 1 section of bellows and 2 pairs of Velcro fasteners.

## BEL-2C-V (For Vertical Twin Shaft Web QuickSlide System 2CA) Dual Shaft Rail Bellows (Dim. in in.)

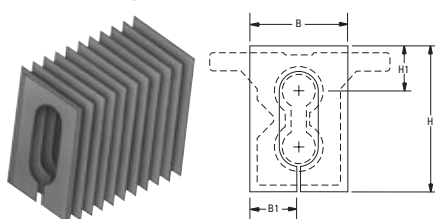

Part Number	Nominal Shaft Diameter	H	H1	B	CR
BEL2C08V	1/2	2.750	1.000	2.125	.163
BEL2C12V	3/4	3.750	1.125	2.375	.163
BEL2C16V	1	4.375	1.250	2.625	.108

Each moveable bellows comes with 1 section of bellows and 2 pairs of Velcro fasteners.



# 2DA QuickSlide System with Brake

## A manual locking mechanism for the Dual Shaft Rail System

### 2DA QuickSlide System with Brake offers:

- A manual locking mechanism with infinite positioning capability.
- No carriage mounting surface deflection when the locking mechanism is activated.
- Immediate off-the-shelf availability in 1/2-, 3/4- and 1-inch sizes.
- A locking mechanism that, when activated, will not apply an increase in load on the system's Ball Bushing® Bearing.
- Zero axial movement during the activation of the locking mechanism.
- A fully supported dual shaft assembly for maximum rigidity and unlimited travel.
- High load capacity in any direction.

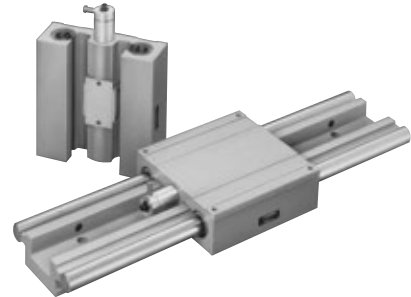

### Dual Shaft Rail Fully Supported System with Integrated Carriage

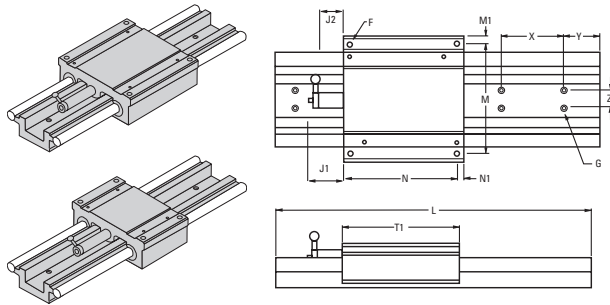

### Dual Shaft Rail Supported Cross-Section

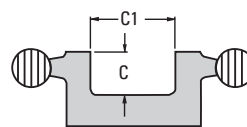

Maximum stroke length is determined by subtracting the carriage length (T1 or T2) plus the brake handle length (J1) from the total system length.

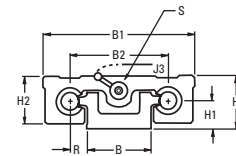

### Dual Shaft Rail Fully Supported System with Integrated Carriage (Long Style) (Dimensions in inches)

Part Number	Nominal Shaft Diameter	Max. Load on System <sup>(1)</sup> (lb.)	Max. Load on One Bearing <sup>(1)</sup> (lb.)	T1	H	H1	H2	B	R	B1	B2	C	C1
2DA0800L	1/2	600	150	4.50	1.625	0.875	1.43	2.00	0.500	4.60	3.00	.64	1.25
2DA1200L	3/4	1880	470	6.00	2.125	1.125	1.93	2.63	0.688	6.10	4.00	.75	1.62
2DA1600L	1	3120	780	7.50	2.625	1.375	2.44	3.25	0.875	7.60	5.00	.99	2.00

(1) For rated travel life of 2 million inches. Note: Manual Brake can be adjusted in order to position handle to any radial location. Dual Shaft Rail Support Material: Aluminum Alloy Black Anodized. Standard length of one-piece Aluminum Dual Shaft Rails is 72".

### Dual Shaft Rail Fully Supported System with Integrated Carriage (Long Style) (Dimensions in inches)

Part Number	N	N1	M	M1	X	Y	Z	J1	J2	J3	F	G		Max. Stroke Length	Carriage Part Number
												Bolt	Hole		
2DA0800L	4.00	.25	4.00	.30	4.00	2.00	.75	1.63	1.19	.88	#10-32	1/4	.28	L-(6.13)	DSRC08SL
2DA1200L	4.25	.37	5.25	.42	6.00	3.00	1.00	1.63	1.19	1.00	1/4-20	5/16	.34	L-(7.63)	DSRC12SL
2DA1600L	6.75	.37	6.75	.42	6.00	3.00	1.25	1.63	1.19	1.00	5/16-18	3/8	.41	L-(9.13)	DSRC16SL

### Dual Shaft Rail Fully Supported System with Integrated Carriage (Short Style) (Dim. in inches)

Part Number	Nom. Shaft Diameter	T2	N2	Max. Stroke Length	Carriage Part Number
2DA0800M	1/2	3.50	3.00	L-(5.13)	DSRC08SM
2DA1200M	3/4	4.50	3.75	L-(6.13)	DSRC12SM
2DA1600M	1	6.00	5.25	L-(7.63)	DSRC16SM

### System 2DA Standard Lengths (Dim. in inches)

System	8"	12"	16"	18"	20"	24"	28"	30"	32"	36"	40"	42"	44"	48"
2DA08	•	•	•	•	•	•	•	•	•	•	•	•	•	•
2DA12	•	•	•	•	•	•	•	•	•	•	•	•	•	•

### Quick Slide Brake Holding Force

System	Axial Holding Force (lb.)
2DA08	125
2DA12	130
2DA16	140

### Custom Lengths and Delivery Information

Custom length systems are available. For special requirements, please contact the Thomson Systems application engineering department.





# Engineering



The Engineering Appendix contains valuable information on the application and use of Thomson Ball Bushing® Bearings, pillow blocks, 60 Case® LinearRace® shafts and supports, and accessories.

<b>Engineering</b> .....	<b>256</b>
Performance Criteria .....	257
Ball Bushing Life Expectancy and Load Capacity.....	261
60 Case LinearRace Shafting Specifications.....	263
Load Consideration .....	264
Coefficient of Friction.....	265
System Maintenance and Service .....	266
Bearing Options .....	267
Material Engineering Specifications.....	268
60 Case LinearRace Deflection .....	269
How to Cut 60 Case LinearRace Shafting.....	270
Application Tips .....	271
Installation Guidelines .....	272
Tolerance Charts.....	273
Engineering Conversion Factors.....	274
Shafting Color Code Chart.....	275

# Performance Criteria

The following performance criteria relates to the use, installation and specification of Thomson Ball Bushing Bearings. Each performance criteria plays an important role in maximizing system effectiveness and life.

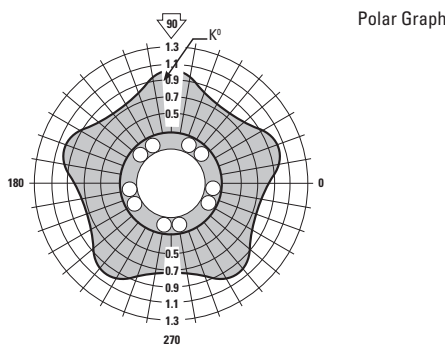
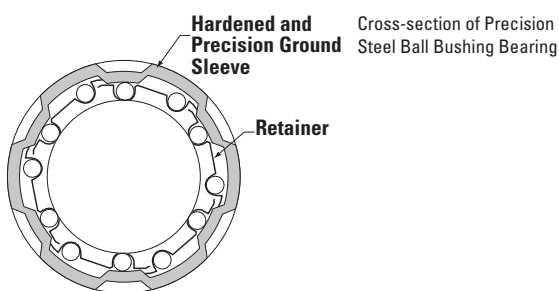
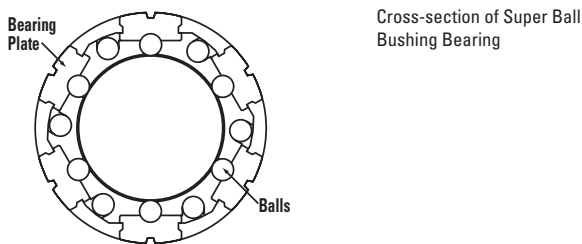
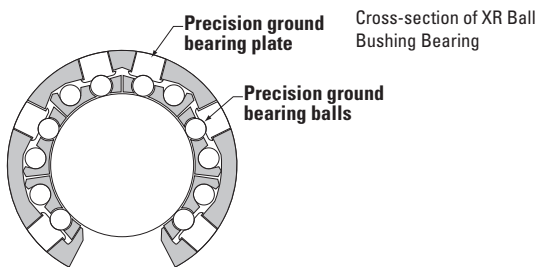
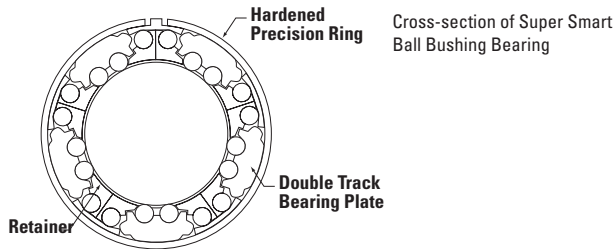

## Dynamic Load Capacity

The dynamic load capacity of a Ball Bushing Bearing is determined by the reaction between the rolling elements and the inner and outer race. The rolling elements in a Ball Bushing Bearing are a series of hardened and precision ground bearing balls. The inner race is a hardened and precision ground 60 Case LinearRace.

The outer race can be a hardened and precision ground, ball conforming, steel bearing plate or a hardened and precision ground steel bearing sleeve. The dynamic load capacity is also affected by the orientation of the ball tracks, the size of the balls, the shape of the ball conforming groove, the number of balls that are in load contact and more.

Since the introduction of the Ball Bushing Bearing in 1945, Thomson has designed and developed Ball Bushing Bearing products that have continuously achieved dramatic increases in dynamic load capacity and life. Our most recent innovation is the Super Smart Ball Bushing Bearing which has six times the dynamic load capacity or 216 times greater life than the traditional Ball Bushing Bearing.

This increase in load capacity was achieved by maximizing the load reaction between the inner and outer races. This breakthrough in load capacity rivals that of linear guides while still retaining the added benefits of the RoundRail Advantage enabling the linear bearing to avoid many of the derating factors that can diminish the load/life performance of square rail products.

The dynamic load capacity of all Thomson Ball Bushing Bearings is based on a L10 life of two million inches (100 km for metric bearings) of travel. The dynamic load capacity can be affected by the orientation of the bearing with respect to the load or the direction of the applied load. A polar graph is included with each product specification to assist you in optimizing the load capacity as well as the performance of the Ball Bushing Bearing. To determine the resultant load capacity, find the angle at which the load is applied to the bearing and move in radially along that line until it intersects the curve. Move around circumferentially to the polar correction value located on the vertical axis. Next, multiply the proper correction factor by the dynamic load capacity listed in each product specification table.



## The RoundRail Advantage

The RoundRail Advantage is the inherent ability of a RoundRail bearing to accommodate torsional misalignment (caused by inaccuracies in carriage or base machining or by machine deflection) with little increase in stress to bearing components (Figure 1). This important feature to all Thomson Ball Bushing® Bearing systems reduces installation time and cost, while

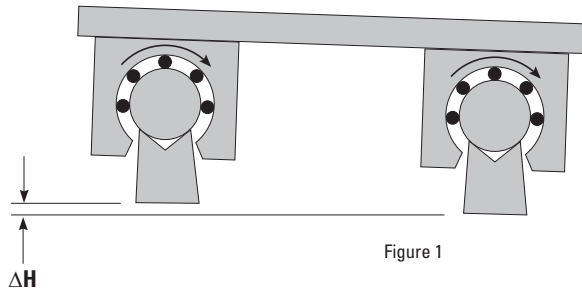

maximizing performance.

### Ball Bushing Bearing vs. Linear Guide

The major difference between a Ball Bushing Bearing and linear guide system is primarily in the design of the inner race. The linear guide inner race has two, four or six ground grooves that guide the carriage and the precision balls. Due to the ball-conforming nature of the grooves, the carriage is prevented from accommodating torsional misalignment (Figure 2). If torsional misalignment is introduced to a linear guide system, the component stress increases, reducing life and performance. In a Ball Bushing Bearing system, the inner race is a hardened and ground 60 Case® LinearRace®. Since there are no grooves, the Ball Bushing Bearing

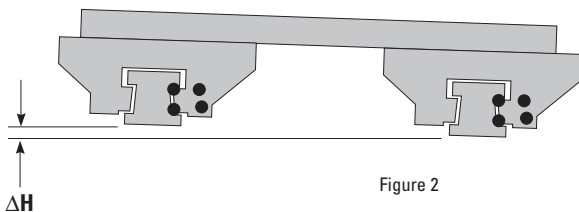

system can accommodate torsional misalignment and operate without added stress to bearing components.

### 60 Case LinearRace/Ball Bushing Bearing Fit-up

There are three basic fit-up conditions of a Ball Bushing Bearing and 60 Case LinearRace: clearance, line-to-line and preload. In most product sections there are specification tables that detail the Ball Bushing Bearing working bore diameter and 60 Case LinearRace diameter tolerance as well as the fit-up between them. The clearance, line-to-line and preload conditions are shown by the abbreviation C for clearance, P for preload and .0000 for a line-to-line condition.

258

### Clearance

The clearance between a Ball Bushing Bearing and a 60 Case LinearRace is a result of the Ball Bushing Bearing working bore diameter and the diameter tolerance of the 60 Case LinearRace. The working bore diameter of a Super Smart or Super Ball Bushing Bearing is a function of the housing bore diameter tolerance. In applications where high accuracy and repeatability is not required, clearance is acceptable. Clearance can be achieved by following the recommended housing bore guidelines found in the product specification sections. To check for a clearance condition, rotate the 60 Case LinearRace inside the Ball Bushing Bearing while installed in a housing bore. If you can freely rotate the 60 Case LinearRace then a clearance condition is present. For more details see the product specification sections.

### Preload

In applications where accuracy and repeatability are critical, the Super Smart, Super and Precision Steel Ball Bushing Bearings can be adjusted to a preload fit-up. The Super Smart and Super Ball Bushing Bearings are inherently adjustable and when installed in an adjustable housing bore a preload condition can be achieved. In a nonadjustable housing a preload condition can be obtained by making the size of the housing bore smaller or by increasing the diameter of the 60 Case LinearRace. To test for a preload condition in an adjustable or nonadjustable housing, simply rotate the 60 Case LinearRace inside the Ball Bushing Bearing while it is installed in the housing bore. If a slight drag is felt then a preload condition is present. When an adjustable housing is used the preload can be altered slightly. The Super Smart and Super Ball Bushing Bearing are more tolerant to preload than the Precision Steel Ball Bushing Bearing. Preload on a Super Smart and Super Ball Bushing Bearing should be a maximum of .001 inch per inch of 60 Case LinearRace diameter. Preload on a Precision Steel Ball Bushing Bearing should be a maximum of .0001 inch per inch of 60 Case LinearRace diameter. When all Ball Bushing Bearings are preloaded, extra care must be taken in mounting the 60 Case LinearRace parallel.

### Line-to-Line

A line-to-line fit-up condition between a Ball Bushing Bearing and 60 Case LinearRace is when no clearance or preload is present. A line-to-line fit-up can be achieved in an adjustable or fixed diameter housing. For more details see the product specification sections.

Examples of Ball Bushing Bearing/60 Case LinearRace Fit-ups (in.)

Ball Bushing Bearing Part Number	Working Bore Diameter	Recommended Housing Bore Diameter (fixed)	Actual Working Bore Diameter	60 Case LinearRace Diameter	Ball Bushing Bearing/60 Case LinearRace Fit Up
SUPER 20	1.2500/1.2494	2.0008/2.0000	1.2508/1.2494	1.2495/1.2490	.0018C/.0001P
A203242	1.2500/1.2494	—	1.2500/1.2494	1.2490/1.2485	.0015C/.0004C
XA203242	1.2500/1.2496	—	1.2500/1.2496	1.2495/1.2490	.0010C/.0001C

The Super Smart Ball Bushing Bearing represents a major advancement in linear bearing technology worldwide. The Super Smart Ball Bushing Bearing offers twice the load capacity or eight times the travel life of the industry standard Super Ball Bushing Bearing. An enormous technological breakthrough, considering the Super Ball Bushing Bearing already offers three times the load capacity or 27 times the travel life of conventional Ball Bushing Bearings.

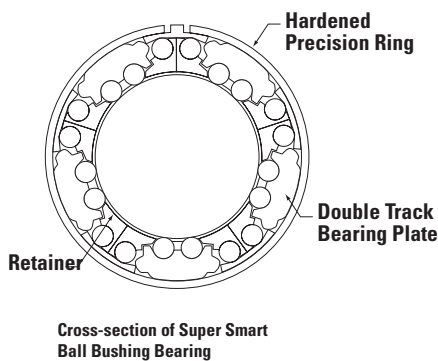

Figure 1  
Cross-section of  
Super Smart Ball  
Bushing Bearing

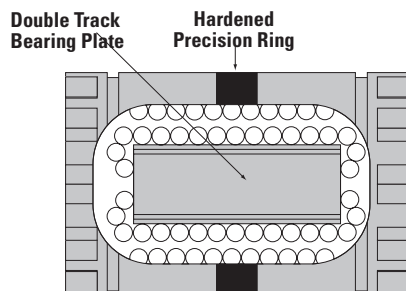

Figure 2

### Technologically Advanced Design

The load carrying component of the Super Smart Ball Bushing Bearing is the combination of four hardened bearing quality steel components (Figures 1 & 2).

The first component is the hardened precision outer ring, which enables the bearing to maintain its diametral fit-up even after extended use, when standard self-aligning bearing plates would imbed into the housing. The unique ring design also allows for bearing adjustment and the removal of diametral clearance. The second component is the precision super finished double track bearing plate that provides twice the load capacity and in combination with the hardened precision steel band provides true universal self-alignment; which means optimum performance even with slight installation imperfections including housing bore out of roundness.

The third component is the rolling element. Each Super Smart Ball Bushing Bearing features precision ground balls manufactured to the highest quality standards for roundness and sphericity. The result is maximum load capacity, travel life and performance.

The last component is the 60 Case LinearRace shaft that functions as the inner race to the Super Smart Ball Bushing Bearing. Each 60 Case LinearRace is manufactured to the highest quality standards for roundness, straightness, surface finish and hardness. Roundness is held under .000080"; straightness to .001" per 12"; surface finish under 8 Ra microinch and hardness of at least 60 HRC. The combination of inner and outer race or 60 Case LinearRace and Super Smart Ball Bushing Bearing provides the fullest embodiment of the RoundRail Advantage.



## Self-Alignment

The Super Smart and Super Ball Bushing® Bearings are equipped with a built-in self-alignment feature that allows the bearing to absorb misalignment up to 0.5° per inch (Figure 3 and 4). This self-aligning feature allows the Super Smart and Super Ball Bushing Bearing to absorb misalignment caused by inaccuracies in housing bore alignment or 60 Case® LinearRace® deflection.

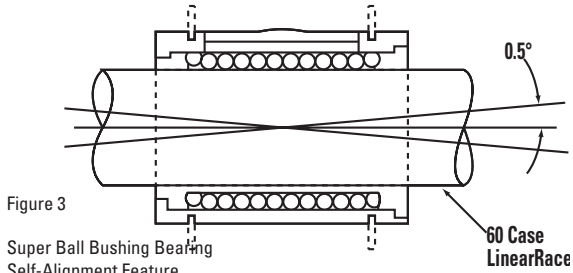

Figure 3  
Super Ball Bushing Bearing  
Self-Alignment Feature

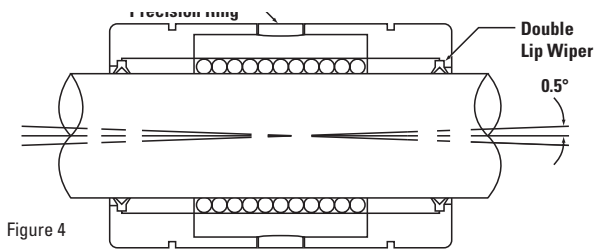

Figure 4  
Super Smart Ball Bushing  
Bearing Self-Alignment  
Feature

This rocking capability also provides smooth entry and exit of the precision balls into and out of the load zone assuring a constant low coefficient of friction. By compensating for misalignment, each bearing ball in the load carrying area is uniformly loaded providing maximum load capacity. Besides this rocking capability, only the Super Smart Ball Bushing Bearing provides two additional self-alignment features. They are Roll and Yaw.

### Roll

The Super Smart Ball Bushing Bearing plate is designed with the radius of its outer surface smaller than the inside radius of the precision outer ring (Figure 5). This feature allows the bearing plate to compensate minor torsional misalignment still distribute the load on each of its two ball tracks. The roll component assures maximum load capacity and travel life.

Figure 5  
Super Smart Ball Bushing  
Bearing Self-Alignment  
Feature

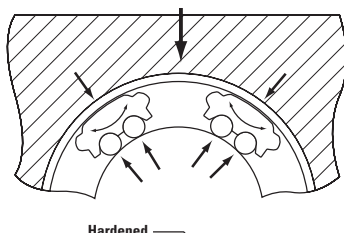

### Yaw

The shape formed by the Rock and Roll features enables the Super Smart Ball Bushing Bearing plate to even rotate about its center (Figure 6). This allows the Super Smart Ball Bushing Bearing to also absorb skew caused by misalignment. The result is a constant low coefficient of friction and maximum bearing performance.

Figure 6  
Bearing plates rotate  
about their center  
to prevent skewing  
relative to the 60 Case  
LinearRace.

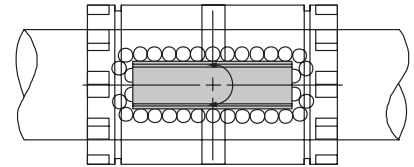

Figure 7 below describes the conditions to which Super Smart and Super Ball Bushings automatically self-align. It is important to note that even though the Super Smart and Super Ball Bushing Bearings self-align, they still cannot absorb an out-of-parallel 60 Case LinearRace condition. Tolerance to 60 Case LinearRace out-of-parallelism is a function of clearance between the bearing and its 60 Case LinearRace.

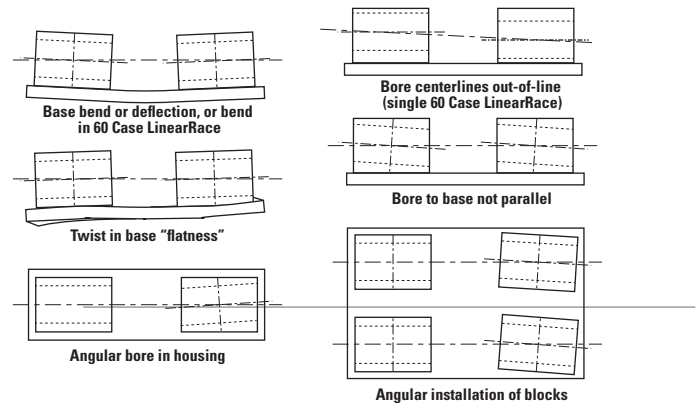

Figure 7

# Ball Bushing Bearing Life Expectancy and Load Capacity

There are many factors that affect Ball Bushing Bearing travel life such as 60 Case LinearRace hardness, the resultant load, the direction of the resultant load and Ball Bushing Bearing orientation. The dynamic load capacities and travel life graphs given in the specification tables found in each product section are based on a load applied at 90° relative to the horizontal plane with the Ball Bushing Bearing oriented as shown in each corresponding polar graph. Note: For Super Smart Ball Bushing Bearings and other extremely high load bearings, the bearing load capacity as indicated by the polar charts may be practically limited by the degree of shaft flexure acceptable, or the capacity of the shaft rail assembly fasteners. In such cases, the loads should be kept below these practical limits, however, the full corresponding life capacity benefits are still realized! The dynamic load capacity is also based on using only Thomson specified 60 Case LinearRace that is hardened to a minimum of 60 HRC.

For considerations other than those described above, the following formula is used:

$$W_R = \frac{P}{K_0 \cdot K_S \cdot K_L}$$

Where:

- $W_R$  = required dynamic load capacity (lb<sub>f</sub> or N)
- $P$  = resultant of externally applied loads (lb<sub>f</sub> or N)
- $K_0$  = factor for direction of resultant load
- $K_S$  = shaft hardness factor (Equals 1.0 for 60 Case LinearRace)
- $K_L$  = load correction factor

## Travel Life

The load correction factor,  $K_L$ , can be found from Figure 1 for inch product, and Figure 2 for Metric product. To determine  $K_L$ , for your required travel life, look for the value on the horizontal axis – Travel Life Factor – left side of the chart. (Interpolate as necessary – this is a Log-Log curve.) That is the value of your load correction factor.

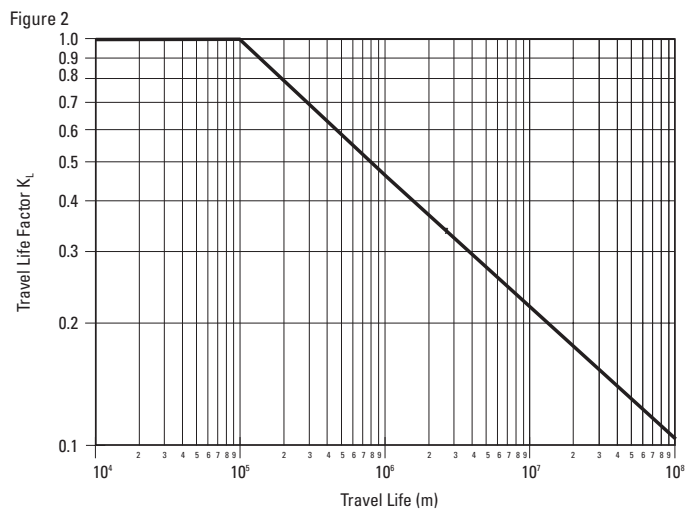
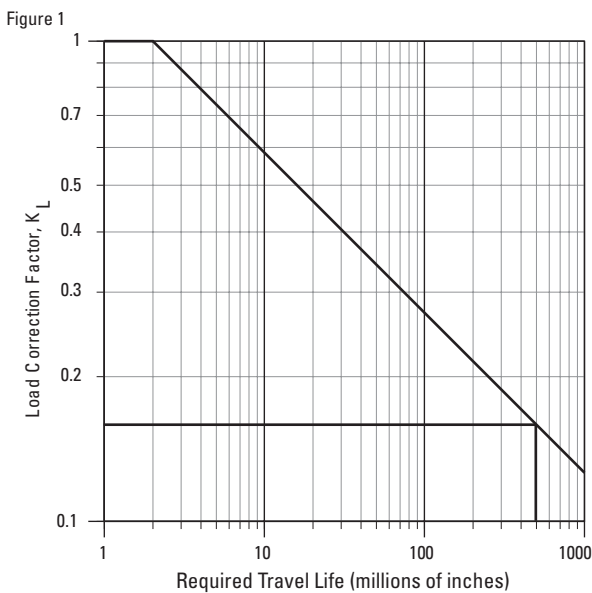

## 60 Case LinearRace Hardness

For shafts that do not meet 60 Case LinearRace hardness specifications of 60 HRC, shaft hardness factor  $K_S$  must be applied. To determine  $K_S$ , simply enter Figure 3 with your shaft Rockwell hardness, find the value on the horizontal axis – Shaft Hardness – bottom of chart. Move vertically up until you intersect the curve. Then move horizontally until you reach the vertical axis – Shaft Correction Factor – left side of chart..

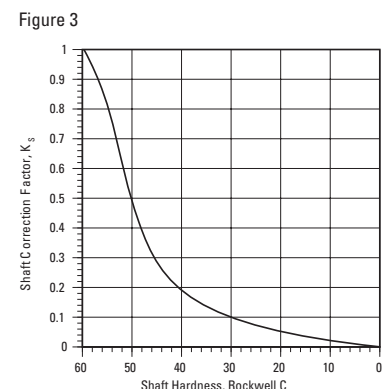



## Load Direction

In applications where the direction of the applied load is known, refer to the polar graphs on the product specification pages for the orientation factor (load correction factor is  $K_L$ ). A polar graph is referenced in Figure 4 for example.

Once you have determined your required dynamic load capacity refer to the product specification table for the proper Ball Bushing® Bearing size.

Note: For Super Smart Ball Bushing Bearings and other extremely high-load bearings, the bearing load capacity as indicated by the polar charts may be practically limited by the degree of shaft flexure acceptable or the capacity of the shaft rail assembly fasteners. In such cases, the loads should be kept below these practical limits, however, the full corresponding life capacity benefits are still realized.

Note: Thomson Linear Ball Bushing Bearings are precision components. To preserve bearing warranty, you must use the specified Thomson 60 Case® LinearRace®.

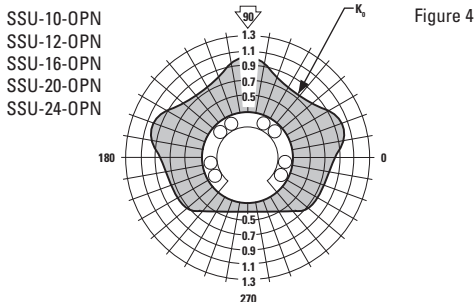

## Load Limit

The load limit is the maximum load which can be applied to the bearing. It is important to analyze your application so that peak and shock loading does not exceed the load limit.

## Dynamic Load Rating

The dynamic load rating is the maximum continuous load that can be applied to the bearing with a 90% reliability of achieving life of two million inches (100 km for metric bearings) under conventional operating conditions. However, it is important to remember that short strokes and the direction of the applied load can be significant factors.

The following formula may be used to determine travel life for metric bearings (SSEM, SPM, and MAM):

$$L_m = \left( \frac{W}{P} \cdot K_o \cdot K_s \right)^3 \cdot 10^5 \text{m}$$

Where:  $L_m$  = travel life (m)  
 $W$  = dynamic load rating from tables (N)  
 $P$  = resultant from externally applied loads (N)  
 $K_o$  = factor for direction of resultant load  
 $K_s$  = shaft hardness factor

## Sample Calculations:

Determine the correct Ball Bushing Bearing size for your application. In this example, the bearing/shaft system is subjected to a load of 2300 N perpendicular to the direction of travel. The load is distributed equally among four closed type MultiTrac® Ball Bushing Bearings. The carriage reciprocates over a 0.3 m stroke at a frequency of 100 complete cycles per minute. The minimum service life required is 3500 hours. 60 Case LinearRace shafting is used.

The first step is to determine the average load on each Ball Bushing Bearing.

$$P = \frac{W}{P} = 575 \text{ N}$$

Next, determine the equivalent travel life in meters:

$$\begin{aligned} L_m &= 2 \cdot s \cdot f \cdot L_h \cdot 60 \\ L_m &= 2 \cdot 0.3 \cdot 100 \cdot 3500 \cdot 60 \\ L_m &= 1.26 \cdot 10^7 \text{m} \end{aligned}$$

Where:  $s$  = stroke in meters  
 $f$  = frequency in cycles per minute  
 $L_h$  = required life in hours

From Figure 1 (Travel Life Chart), the travel life factor ( $K_L$ ) is 0.2.  
 From Figure 2 (Shaft Hardness Chart), the shaft hardness factor ( $K_S$ ) is 1.

For closed type MultiTrac Ball Bushing Bearings, the minimum value of  $K_o$  is 1, the assumed value for this calculation.

The required dynamic load capacity is obtained by using the following formula:

$$W_R = \frac{P}{K_L \cdot K_S \cdot K_o} \quad W_R = \frac{575}{0.2 \cdot 1 \cdot 1} = 2875 \text{ N}$$

By referring to the product specification and dimension sections of this catalog, the linear bearing with the next higher load capacity is the MultiTrac MA M40 with a dynamic load capacity of 3820 N.

## Determining the Travel Life

The expected travel life of the MultiTrac MA M40 bearing under the conditions described in the example is:

$W = 3820 \text{ N}$  is the rated dynamic load capacity  
 $P = 575 \text{ N}$  is resultant of external loads  
 $K_o = 1$  is the orientation factor  
 $K_s = 1$  is the shaft hardness factor

The values are substituted into the following formula:

$$\begin{aligned} L_m &= \left( \frac{W}{P} \cdot K_o \cdot K_s \right)^3 \cdot 10^5 \text{m} \\ L_m &= \left( \frac{3820}{575} \cdot 1 \cdot 1 \right)^3 \cdot 10^5 \text{m} \\ L_m &= 293 \cdot 10^5 \end{aligned}$$

This is converted into hours by the following:

$$\begin{aligned} L_h &= \frac{L_m}{2 \cdot 60 \cdot s \cdot f} \\ L_h &= \frac{293 \cdot 10^5}{2 \cdot 60 \cdot 0.3 \cdot 100} \\ L_h &= 8139 \text{ h} \end{aligned}$$





# Load Consideration

When designing a linear motion system, it is necessary to consider how the variables of operation will affect performance.

The following examples demonstrate how the position of the load and the center of gravity can influence the product selection. When evaluating your application, review each of the forces acting on your system and determine the best product for your needs.

## Terms:

- $d_0$  = distance between centerlines of pillow blocks
- $d_1$  = distance between centerlines of 60 Case® LinearRace® ways  
(recommended spacing on  $d_1$  is no more than 3x the  $d_0$  distance)
- $d_2$  = distance from centerline of carriage to load action point
- $d_3$  = distance from centerline of carriage to load action point
- $W$  = Load (lb)
- $F_{NX}$  = Force in the X-axis direction (lb<sub>f</sub> or N)
- $F_{NY}$  = Force in the Y-axis direction (lb<sub>f</sub> or N)
- $F_{NZ}$  = Force in the Z-axis direction (lb<sub>f</sub> or N)

$$F_{1z} = \frac{W}{4} + \left( \frac{W}{2} \cdot \frac{d_2}{d_0} \right) - \left( \frac{W}{2} \cdot \frac{d_3}{d_1} \right)$$

$$F_{2z} = \frac{W}{4} - \left( \frac{W}{2} \cdot \frac{d_2}{d_0} \right) - \left( \frac{W}{2} \cdot \frac{d_3}{d_1} \right)$$

$$F_{3z} = \frac{W}{4} - \left( \frac{W}{2} \cdot \frac{d_2}{d_0} \right) + \left( \frac{W}{2} \cdot \frac{d_3}{d_1} \right)$$

$$F_{4z} = \frac{W}{4} + \left( \frac{W}{2} \cdot \frac{d_2}{d_0} \right) + \left( \frac{W}{2} \cdot \frac{d_3}{d_1} \right)$$

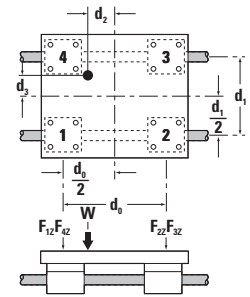

### Horizontal Application I

At the time of movement with uniform velocity or at the time of stop.

$$F_{1z} = \frac{W}{4} + \left( \frac{W}{2} \cdot \frac{d_2}{d_0} \right) - \left( \frac{W}{2} \cdot \frac{d_3}{d_1} \right)$$

$$F_{2z} = \frac{W}{4} - \left( \frac{W}{2} \cdot \frac{d_2}{d_0} \right) - \left( \frac{W}{2} \cdot \frac{d_3}{d_1} \right)$$

$$F_{3z} = \frac{W}{4} - \left( \frac{W}{2} \cdot \frac{d_2}{d_0} \right) + \left( \frac{W}{2} \cdot \frac{d_3}{d_1} \right)$$

$$F_{4z} = \frac{W}{4} + \left( \frac{W}{2} \cdot \frac{d_2}{d_0} \right) + \left( \frac{W}{2} \cdot \frac{d_3}{d_1} \right)$$

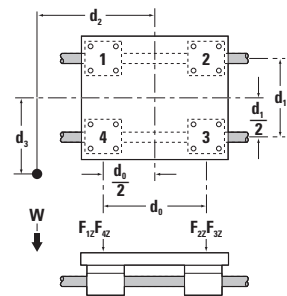

### Horizontal Application II

At the time of movement with uniform velocity or at the time of stop.

$$F_{1y} \cong F_{4y} = \left( \frac{W}{2} \cdot \frac{d_3}{d_1} \right)$$

$$F_{1z} = F_{4z} = \frac{W}{4} + \left( \frac{W}{2} \cdot \frac{d_2}{d_0} \right)$$

$$F_{2z} = F_{3z} = \frac{W}{4} - \left( \frac{W}{2} \cdot \frac{d_2}{d_0} \right)$$

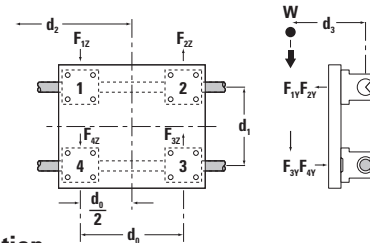

### Side Mounted Application

At the time of movement with uniform velocity or at the time of stop.

$$F_{1x} \cong F_{4x} = \frac{W}{2} \cdot \frac{d_2}{d_0}$$

$$F_{1y} \cong F_{4y} = \frac{W}{2} \cdot \frac{d_3}{d_0}$$

$$F_{1x} + F_{4x} \cong F_{2x} + F_{3x}$$

$$F_{1y} + F_{4y} \cong F_{2y} + F_{3y}$$

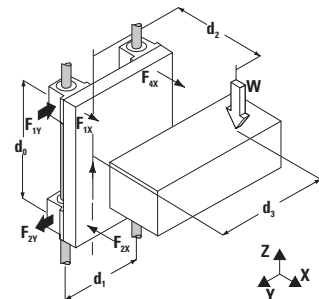

### Vertical Application

At the time of movement with uniform velocity or at the time of stop. At the time of start and stop, the load varies because of inertia.

# Coefficient of Friction

The coefficient of friction of Thomson Ball Bushing® Bearings ranges from 0.001 to 0.004. There are two components of the coefficient of friction: the rolling or operating friction and the static or breakaway friction.

## Coefficient of Rolling Friction

The rolling coefficient of friction is measured by the force required to operate the Ball Bushing at a constant rate of travel. The formula for determining frictional resistance during operation is as follows:

$$P_f = P \times f_r$$

Where,

$P_f$  = Frictional resistance (lb<sub>f</sub>)

$P$  = Resultant of externally applied loads (lb<sub>f</sub>)

$f_r$  = Coefficient of rolling friction

The following table describes the coefficient of rolling friction of Ball Bushing Bearings operating on Thomson 60 Case LinearRace. These values are grouped according to the number of ball circuits in each bearing. Friction coefficients are constant among bearings having three and four ball circuits, but slightly less for bearings with five or six ball circuits. A dry Ball Bushing Bearing has the lowest coefficient of friction due to the complete absence of lubricant surface tension effects. Values for grease lubrication ranges from 100% greater in the smaller sizes to 20% to 50% greater in the larger sizes. Oil lubrication (medium/heavy, viscosity 64 cs @ 100°F / 38°C) achieves frictional values slightly higher than those for grease lubrication.

Ball Bushing Bearing coefficients of rolling friction ( $f_r$ )

Bearing I.D.	Number of Ball Circuits	Condition of Lubrication	Load in % of Rolling Load Rating (for 2,000,000 inches of travel)				
			125%	100%	75%	50%	25%
1/4, 3/8, 1/2, 5/8	3 & 4	No Lube	.0011	.0011	.0012	.0016	.0025
		Grease Lube	.0019	.0021	.0024	.0029	.0044
		Oil Lube	.0022	.0023	.0027	.0032	.0045
3/4, 1	5	No Lube	.0011	.0011	.0012	.0015	.0022
		Grease Lube	.0018	.0019	.0021	.0024	.0033
		Oil Lube	.0020	.0021	.0023	.0027	.0036
1 1/4 thru 1	6	No Lube	.0011	.0011	.0012	.0014	.0019
		Grease Lube	.0016	.0016	.0017	.0018	.0022
		Oil Lube	.0018	.0018	.0019	.0021	.0027
5/8 thru 1 1/2	10	No Lube	.0011	.0011	.0012	.0013	.0018
		Grease Lube	.0014	.0014	.0015	.0016	.0019
		Oil Lube	.0016	.0016	.0017	.0019	.0025

## Coefficient of Static Friction

The coefficient of static or breakaway friction is measured by the force required to initiate Ball Bushing Bearing movement. The formula used to determine static frictional resistance is:

$$P_f = P \times f_0$$

where  $f_0$  = Coefficient of static friction

The values for the coefficient of static friction or breakaway friction are not measurably affected by the number of ball circuits in the bearing or by the lubrication condition.

Ball Bushing Bearing coefficients of static friction ( $f_0$ )

Load in % of Rolling Load Rating				
125%	100%	75%	50%	25%
.0028	.0030	.0033	.0036	.0040

## Seal Drag

Another variable that affects the frictional resistance in a Ball Bushing Bearing system is seal drag. When seals are used to retain lubricant or to prevent entry of foreign particles, frictional resistance must be taken into account for determining total frictional drag. In applications where contamination is minimal, the seals can be removed to reduce frictional drag. In highly contaminated applications, seals, wipers and or scrapers are used to minimize the ingress of contamination into the bearing. This protective measure adds to the frictional drag of the bearing system. There is a fine line between minimizing frictional drag and maximizing contaminant protection which is controlled by the addition or removal of seals, wipers or scrapers. In applications that require low frictional drag in highly contaminated environments, contact Thomson application engineering.

Thomson can provide a specially formulated lubricant, specifically developed to meet a broad range of linear bearing applications. Thomson LinearLube lubricant is a synthetic lubricant that utilizes suspended Teflon® in a specially formulated compound. LinearLube lubricant provides excellent performance characteristics in a wide range of applications. It is FDA listed, non-polluting and non-corrosive. LinearLube lubricant will not stain and adheres tightly to parts forming a virtually water resistant barrier.

- Maintains properties in operating temperatures from -65°F to 450°F / -54°C to 232°C
- USDA Rated HL (Non-Toxic)
- Will not oxidize in use
- 100% water resistant



## System Maintenance and Service

All Thomson Ball Bushing® Bearings require a small amount of grease or oil to operate. For general applications, EP2 (extreme pressure NLGI grade2) lubricant is recommended to prevent wearing and rusting of the bearing surfaces. For food-grade applications, LinearLube (teflon-based synthetic grease) is recommended. When linear speeds are high, light oil should be used and the bearing should be prevented from running dry for a prolonged period of time. A medium to heavy oil or light grease has greater adhesion properties that afford longer bearing protection and minimize sealing problems.

All Thomson Ball Bushing Bearings are shipped with rust preventative oil. It is recommended that you lubricate the Ball Bushing prior to installation and periodically during operation to assure that the Ball Bushing does not run dry. Bearing lube cycle not to exceed 1 year or 100 km of travel (whichever comes first), but more frequent application may be required based on duty cycle, usage, environment and level of contamination.

Thomson can provide a specially formulated lubricant, specifically developed to meet a broad range of linear bearing applications. Thomson LinearLube lubricant is a synthetic lubricant that utilizes suspended Teflon® in a specially formulated compound. LinearLube provides excellent performance characteristics in a wide range of applications. It is FDA listed, non-polluting and non-corrosive. LinearLube will not stain and adheres tightly to parts forming a virtually water resistant barrier.

- Maintains properties in operating temperatures from -65°F to 450°F / -54°C to 232°C
- USDA rated HL (Non-Toxic)
- Will not oxidize in use
- 100% water resistant

## Bearing Options

### Ball Options

- CR Corrosion Resistant: This option is available on all Super and Super Smart Bushing Bearings and pillow blocks. The option provides stainless steel balls and plated bearing plates. For Super Smart, the outer band is also plated. Using stainless steel balls will reduce the dynamic load capacity by 30%.
- SS Stainless Steel: This option is available for metal A Bearings and MultiTrac® metric (MAM) bearings. The option provides stainless steel instead of carbon steel and stainless steel balls. For A Bearings, this is available up to and including 1" sizes. For MAM bearings, this option is available for all sizes except 40mm. Using stainless steel balls will reduce the dynamic load capacity by 30%.
- SP Stainless Steel Balls, Black Oxide Retainer and Sleeve: This option is available for all metal A Bearings and MultiTrac metric (MAM) bearings, and is a good alternative to –SS. Using stainless steel balls will reduce the dynamic load capacity by 30%.
- NB Nylon Balls: This option provides full nylon balls in place of carbon steel balls, resulting in a quiet bearing but reducing the load capacity by 90%. Available on all bearings.
- NBA Alternating Nylon Balls: This option is useful when a more quiet than standard bearing is desired but full nylon is not needed. This will reduce dynamic load capacity by 50%. Available on all bearings.
- OR Outrigger: Only two opposing bearing tracks.

### Lube Options

- LL Bearing is lubricated at the factory with Thomson LinearLube.
- L4L Pillow block furnished with a Lube for Life cartridge on each end. This option is available on Super and Super Smart inch pillow blocks, sizes ½", ¾", 1", 1 ¼" & 1 ½".
- DP Bearing is shipped with no lubricant at all. (Typically all ball bearings are shipped with rust preventative only.)

### Other Options

- RP The Roll Pack option eliminates the packing box. This may be desired on larger quantity orders.
- HP The bearing is treated with a black oxide finish. This option is available on metal A Bearings and MultiTrac metric (MAM) bearings.

Note: Up to 1 option per option category can be selected. (Example, A162536-SPLLRP)

Not all options are available in all sizes.

See catalog pages or contact Thomson Customer Support for combination availability.



# Material Engineering Specifications

## Ball Bushing® Bearing materials

The following is a tabulation of the materials used for the components of the various types of Ball Bushing Bearings

Type	Outer Sleeve	Ball Retainers	Bearing Plates	Balls	End Rings/Band
SSU, SSJM, SSEM, SPM, SUPER Ball Bushing Bearings	Delrin	Delrin	52100	Chrome Steel	None/Steel
Series A, B, XA, ADJ, OPN and DS	52100	Steel	–	Chrome Steel	Steel
Stainless Steel (SS) to 1" I.D. Series A, XA, ADJ and OPN	440A	Type 305SS	–	440C	Type 303SS
Series MAM	–	Delrin	–	Chrome Steel	Steel
Series INST-SS	440C	Brass	–	440C	None
Series XR	Reinforced Nylon	Reinforced Polyester	8620	Chrome Steel	Steel

Note: Materials called out are typical, certain series and sizes may vary.

## Corrosion Resistance

Super and Super Smart Ball Bushing Bearings can be supplied corrosion resistant with hard chrome-plated bearing plates and stainless steel balls. Load capacity will be 70% of regular Super Ball Bushing Bearings. To order, add suffix "CR" following the Super Ball Bushing Bearing part number.

Large sizes (over 1" diameter) of series A, XA, ADJ, OPN and B, Ball Bushing Bearings can be supplied with stainless steel balls and black oxide sleeves for limited protection against atmospheric corrosion. Load capacity will be 70% of regular steel bearings. To order, add suffix "SP" following the bearing part number.

## Stainless Steel Ball Bushing Bearings

Precision and MultiTrac® Ball Bushing Bearings can be supplied with stainless steel ball and end rings. To order, add suffix "SS" following the bearing part number. Precision bearings are made entirely of stainless steel components. MultiTrac bearings have stainless steel balls, end rings and outer sleeves. Load capacity will be 70% of regular steel bearings.

### Sizes available:

Series A and XA: 1/4", 3/8", 1/2", 5/8", 3/4" and 1"  
 Series ADJ and OPN: 1/2", 5/8", 3/4" and 1"  
 Series MAM: 8mm (closed type only), 12mm, 16mm, 20mm, 25mm, 30mm

## Ball Bushing Bearings with nylon balls

For extremely quiet operation, Ball Bushing Bearings fitted with Nylon balls can be supplied in sizes 1/2" and larger. For estimating purposes, load ratings should be considered about 10% of those listed for Ball Bushing Bearings with steel balls. Prices and other information available on request.

NBA Bearings have a load rating of 50% listed dynamic.

## 60 Case® shafts – hardened and ground

Material Type	AISI	Rockwell "C"
Solid 60 Case	Bearing-quality, high carbon alloy steel	60 min
Tubular 60 Case	Bearing-quality, high carbon alloy steel	58 min
Solid Stainless Steel	440C Stainless <sup>(1)</sup>	50 min

(1) For applications using 440C stainless shafting with Thomson Ball Bushing Bearings, contact Thomson Customer Support with full application details for applicable load derating considerations.

## Maximum recommended operating temperatures for RoundRail bearings

The following are general recommendations. For additional information or more specific recommendations please contact Thomson Customer Support with full application details.

Type of Ball Bushing Bearings	Maximum Operating Temperature	Load Rating at Maximum Operating Temperature as % of Catalog Load Rating
Series Super Smart, Super, MultiTrac & XR	185°F / 85°C	100%
Series A, B, XA, ADJ & OPN <sup>(2)</sup> , Series DS, and Series RW S, V, A, B & C	500°F / 260°C	70%
Series A-SS, XA-SS, ADJ-SS, OPN-SS & INST-SS Stainless Steel (through 1" I.D.) <sup>(2)</sup>	600°F / 316°C	60%

(2) Maximum operating temperature for these two series for full catalog load rating is 300°F/149°C.

Note: Type PB-A, PB-ADJ and PBO-OPN pillow blocks are assembled with plastic seal covers with a maximum operating temperature at 185°F. Remove seals and seal covers for use in higher temperatures.

Note: Seals max temperature is 250°F / 121°C.

Note: Shafting loses 5 points hardness for every 100°F / 38°C above 200°F / 93°C.

Note: For extreme minimum temperatures, contact Thomson Customer Support.

## Pillow blocks and shaft supports

Part Type	Material
Type Super Smart and Super – Pillow Blocks, Flanged Blocks and Aluminum Shaft Blocks	Type 6061-T6511 Aluminum
Type PB pillow blocks	Ductile Iron
Type PBO & XPBO pillow blocks	Malleable/Ductile Iron
Type SR shaft support rails	Type 6061-T6511 Aluminum
Type LSR shaft support rails	1010 Steel
Type XSR shaft support rails	Ductile Iron
Type SB shaft support blocks	Malleable Iron <sup>(3)</sup>

(3) Type 6061-T6511 Aluminum for 1/4" and 3/8" sizes only

## RoundRail linear guides

	Components	Material
Supports	Type ASB End Support	Aluminum Alloy <sup>(4)</sup>
	Type SB End Support	Iron
	Type SRA End Support	Aluminum Alloy <sup>(4)</sup>
	Twin Shaft End Support	Aluminum Alloy <sup>(4)</sup>
	Twin Shaft Web End Support	Aluminum Alloy <sup>(4)</sup>
	Integrated End Support	Aluminum Alloy <sup>(4)</sup>
	Dual Shaft Support Rail	Aluminum Alloy <sup>(4)</sup>
Carriage	Inner Race (60 Case Shafting)	Case Hardened High Carbon Steel
	Universal Carriage	Aluminum Alloy <sup>(4)</sup>
	Twin Shaft Carriage	Aluminum Alloy <sup>(4)</sup>
	Twin Shaft Web Carriage	Aluminum Alloy <sup>(4)</sup>
	Modular Dual Shaft Carriage	Aluminum Alloy <sup>(4)</sup>
	Integrated Dual Shaft Carriage	Aluminum Alloy <sup>(4)</sup>

(4) Custom Black Anodized for inch size systems. Custom Grey Anodized for metric size systems. Custom system lengths may require black paint to protect machine cut-off ends on Dual Shaft Rail Assemblies and Shaft support rails. If a specific surface finish is required contact Thomson Customer Support.

Note: Limited to a Max. Temperature of 185°F / 85°C

# 60 Case<sup>®</sup> LinearRace<sup>®</sup> Deflection

When Thomson 60 Case LinearRace is used in an end-supported configuration, it is important to ensure that 60 Case LinearRace deflections at the bearing locations are kept within performance limitations.

These equations give the deflection at the center of an end-supported 60 Case LinearRace. Systems with continuous 60 Case LinearRace support are not subject to the same types of deflection.

For more detailed information of the deflection characteristics of Thomson linear motion products, contact application engineering.

## Simply Supported 60 Case LinearRace with One Block

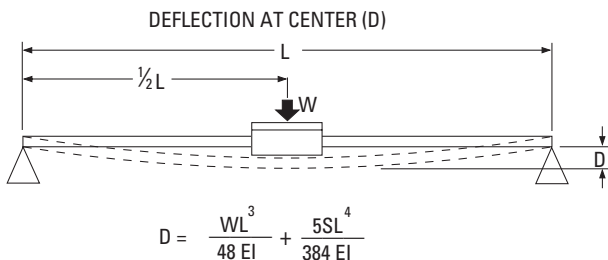

## Simply Supported 60 Case LinearRace with Two Blocks

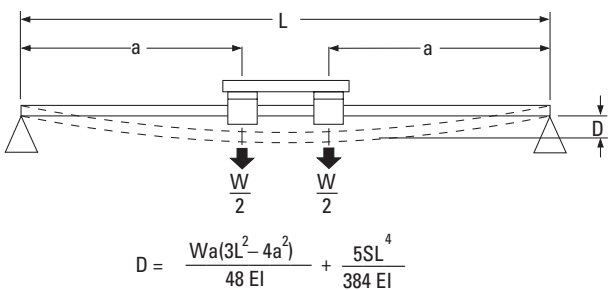

**LEGEND:**

- D = (in) (m)
- W = (lb,) (N)
- L = (in) (m)
- a = (in) (m)
- S = (lb./in) (N/m)
- E = (lb./in<sup>2</sup>) (N/m<sup>2</sup>)
- I = (in<sup>4</sup>) (m<sup>4</sup>)

## Values for Thomson 60 Case LinearRace

LinearRace Diameter (In)	Solid		Tubular	
	EI (lb. • in <sup>2</sup> )	Weight (S) (lb./ in)	EI (lb. • in <sup>2</sup> )	Weight (S) (lb./ in)
.187	1.8E+03	.008	—	—
.250	5.8E+03	.014	—	—
.375	2.9E+04	.031	—	—
.500	9.2E+04	.055	—	—
.625	2.3E+05	.086	—	—
.750	4.7E+05	.125	4.6E+05	.075
1.000	1.5E+06	.222	1.3E+06	.158
1.250	3.6E+06	.348	—	—
1.500	7.5E+06	.500	6.3E+06	.328
2.000	2.4E+07	.890	1.9E+07	.542
2.500	5.8E+07	1.391	4.2E+07	.749
3.000	1.2E+08	2.003	9.3E+07	1.112
4.000	3.8E+08	3.560	2.5E+08	1.558

LinearRace Diameter (mm)	EI (N • m <sup>2</sup> )	Weight (S) (N/m)
5mm	5.838	0.0016
8mm	38.26	0.0038
10mm	93.41	0.0061
12mm	193.7	0.0087
16mm	612.2	0.0154
20mm	1495	0.0240
25mm	3649	0.0379
30mm	7566	0.0542
40mm	2.391E+04	0.0968
50mm	5.838E+04	0.1513
60mm	1.211E+05	0.2172
80mm	3.826E+05	0.3870

## Deflection for Twin Shaft Web System

Since the Twin Shaft Web rail has different stiffness depending on its orientation, an appropriate EI value must be used based upon the direction of loading. Select the orientation of your load from the figure below and then use the appropriate EI value in the deflection equation.

Shaft Diameter (in)	EI Horizontal (lb. • in <sup>2</sup> )	EI Vertical (lb. • in <sup>2</sup> )
1/2	1.9E+05	3.7E+06
3/4	9.4E+05	1.5E+07
1	3.0E+06	4.7E+07

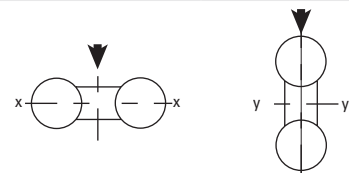



## How to Cut 60 Case® LinearRace® Shafting

Genuine 60 Case LinearRace shafting has an extremely hard outer surface, HRC 60 and a soft core. The following steps will guide you in cutting 60 Case shafts. Remember: Always use goggles and normal shop safety precautions.

### With an abrasive cut-off saw . . . (preferred method)

**Step 1:**  
Mark the shaft at the desired length.



**Step 2:**  
Secure shaft in vise with longer end clamped.

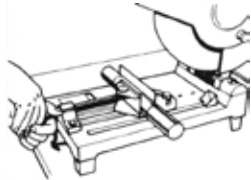

**Step 3:**  
Cut the shaft at the mark.

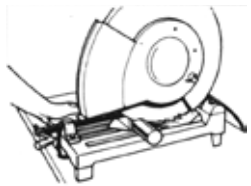

**Step 4:**  
Chamfer the shaft by rotating it by hand while holding it against an abrasive wheel at approximately 45°. Use an emery cloth to remove burrs and discoloration.

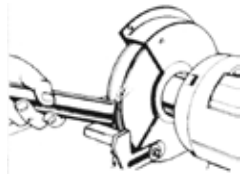

### With a lathe . . . (using a collect type or standard 3-jaw chuck)

**Step 1:**  
Mark the shaft at the desired length.



**Step 2:**  
Secure shaft in lathe with longer end in spindle.

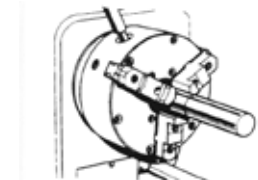

**Step 3:**  
Use a sharp, carbide cut-off tool with shaft turning at approx. the following speeds: 400 rpm for dia. 1/4" - 1", and 300 rpm for dia. 1" or larger.

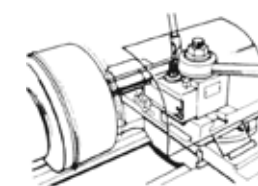

**Step 4:**  
Chamfer the shaft using a standard carbide turning tool or an abrasive wheel. Use an emery cloth to remove burrs and discoloration.

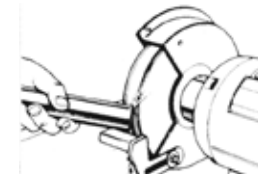

## Application Tips

### Two Ball Bushing® Bearings per 60 Case LinearRace

When using the Super Smart, Super or Precision Steel Ball Bushing Bearing, it is recommended that two Ball Bushing Bearings be used on each 60 Case LinearRace. This will assure system stability as well optimum performance. If envelope constraints prohibit the use of two Ball Bushing Bearings per 60 Case LinearRace, contact application engineering.

### Ball Bushing Bearing Spacing vs. 60 Case LinearRace Spacing

In parallel 60 Case LinearRace applications, the ratio of 60 Case LinearRace spacing to Ball Bushing Bearing spacing should always be less than three to one. This will assure a constant breakaway and operating friction.

### 60 Case LinearRace Parallelism

In most applications the maximum acceptable out of parallelism condition is .001" over the entire full system length. In applications where preload is present (such as when using Die Set Ball Bushing Bearings), a closer 60 Case LinearRace parallelism is recommended.

### Three or More Parallel 60 Case LinearRace Ways

When aligning two 60 Case LinearRace ways parallel great care is required to assure a parallelism within .001" over the entire length of travel. When aligning multiple 60 Case LinearRace ways, parallelism between each 60 Case LinearRace should be held within the .001" specification.

### Measuring 60 Case LinearRace Alignment

Methods for establishing or checking 60 Case LinearRace straightness and parallelism depends on the accuracy required. Lasers, collimator or alignment telescopes can be used for very precise applications, while accurate levels, straight edges, micrometers and indicators will suffice for the majority of applications which have less stringent accuracy requirements.

### Installation of Super and Precision Steel Adjustable Type Ball Bushing Bearings

When installing a Super Ball Bushing Bearing into a slotted adjustable housing, the bearing plate should not align with the adjustment slot. When installing a Precision Steel Adjustable Type Ball Bushing Bearing into a slotted adjustable housing, the bearing adjustment slot should be 90° to the pillow block adjustment slot. These important steps will assure accurate bearing adjustment.

### Access for Lubrication

Thomson Super Smart and Super Ball Bushing Pillow Blocks are equipped with either an oil lubrication fitting or a 1/4-28 access for lubrication. To use the oil fitting simply insert a lubrication device into the oil nipple by depressing the spring loaded ball. The 1/4-28 tapped hole is a standard size for most grease and lubrication fittings. Simply install the lubrication fitting of your choice and it is ready for immediate use. Super Ball Bushing Pillow blocks in sizes .250 through .500 inch diameter are equipped with oil lubrication fittings. Super Ball Bushing pillow blocks in sizes .625 inch and above and all Super Smart Ball Bushing Pillow Blocks are equipped with a 1/4-28 access for lubrication. Metric Super Smart Pillow Blocks are equipped with a M6X1 access for lubrication.

### RoundWay® Bearing/60 Case LinearRace Installation Using Grout

Grouting is a very simple method of mounting a 60 Case LinearRace on almost any kind of surface, smooth or uneven. Grouting can also be used in conjunction with 60 Case LinearRace supports to obtain maximum rigidity. Dams are fastened to the bed parallel to the 60 Case LinearRace which is then aligned with its mating 60 Case LinearRace (Figure 1). A compound is then poured under and around the lower circumference of the 60 Case LinearRace. This dries quickly forming a solid support of high compressive strength (over 12,000 psi) without affecting the initial straightness of the LinearRace.

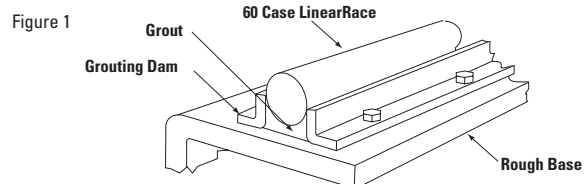

If the bearing arrangement permits the grout to flow substantially around the circumference of the 60 Case LinearRace and side loads are light, hold down bolts along the length made be unnecessary (Figure 2). Just one support at each end of the 60 Case LinearRace will usually provide final alignment and hold the 60 Case LinearRace in position for grouting. Grout should always be in direct contact with the surface of the bed or whatever base member provides primary rigidity and support.

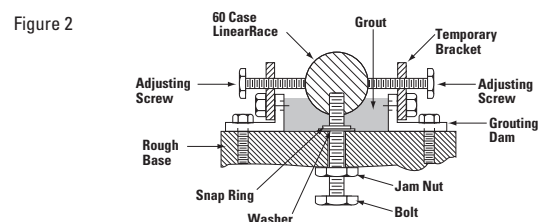



## Installation Guidelines

Thomson Ball Bushing® Bearings are manufactured to exceptionally close tolerances and offer smooth, virtually friction-free motion. The performance features of the bearings will only be realized, however, if care is taken during their installation.

Two areas of primary importance are the bearings alignment and the shaft parallelism. Two bearings are normally used on each shaft to assure smooth operation. The housing should be carefully aligned using the method given below. If a single twin-type housing is used, these procedures are not necessary. It is also necessary to assure that the height from the housing mounting surface to the shaft is consistent within .001". Shimming may be necessary depending on the accuracy of the mounting surfaces to which the housings are bolted.

The housing can be mounted to the plate using the following procedure:

- Prepare the carriage plate with one side having an abutting surface.
- Mount two housings with the reference edges located against the abutting surface and tighten the hold down bolts. Figure #1
- Mount the second pair of housings on the opposite side of the carriage and tighten the bolts finger tight.
- Insert a location shaft of correct diameter and tolerance (h6) through these two housings and reference the distance from the abutting surface in [b] above, to this locating shaft. Figure #2
- After appropriate alignment of this pair of housings, tighten bolts to secure housings to carriage.

After the carriage is properly prepared, the shafts must be mounted to the surface. To achieve smooth, accurate motion, the shafts must be mounted parallel within .001 inch over the length of the stroke. This can be done by using the following procedure:

- Mount one shaft (either end-supported or fully supported) to the surface with mounting bolts finger tight.
- Using an aligning device such as a laser, auto-collimator or other optics, sight the shaft straight and secure to mounting surface.
- After this first shaft is fixed, the second shaft can be positioned and held down with bolts finger tight.
- The carriage is then mounted and its movement will pull this second shaft parallel to the first. Figures #3 and #4
- If the second shaft is then secured into position, the procedure is complete. Note that for fully supported systems, this securing should be done when the carriage is close to the bolts. For end supported systems, the securing should be done when the carriage is at the ends of the shafts. Figure #5
- An additional check can be done at this time to assure that the carriage is tracking correctly (i.e., that the carriage edge is moving parallel to the shaft). An indicator touching the carriage edge should not vary, as the carriage is moved along the shafts. Figure #6

Figure 1

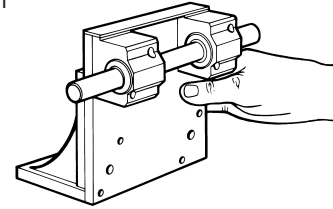

Figure 2

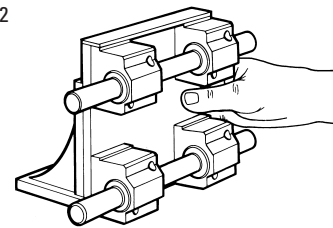

Figure 3

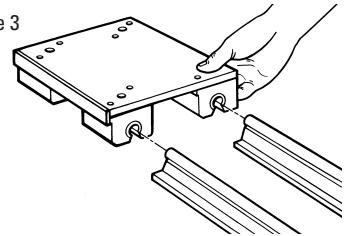

Figure 4

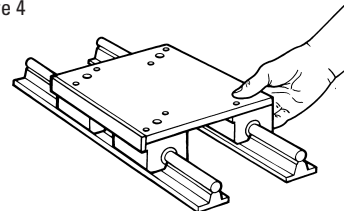

Figure 5

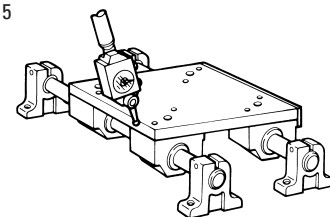
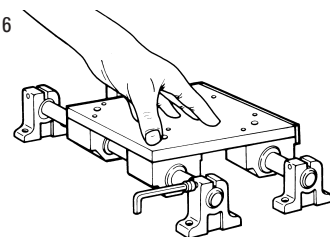

Figure 6



# ISO Tolerance Charts

## Tolerance zones for internal (hole) dimensions (H15 through H5) (Dimensions in mm)

Basic Size	H15	H14	H13	H12	H11	H10	H9	H8	H7	H6	H5
Over 6	+0.580	+0.360	+0.220	+0.150	+0.090	+0.058	+0.036	+0.022	+0.015	+0.009	+0.006
To 10	0.000	0.000	0.000	0.000	0.000	0.000	0.000	0.000	0.000	0.000	0.000
Over 10	+0.700	+0.430	+0.270	+0.180	+0.110	+0.070	+0.043	+0.027	+0.018	+0.011	+0.008
To 14	0.000	0.000	0.000	0.000	0.000	0.000	0.000	0.000	0.000	0.000	0.000
Over 14	+0.700	+0.430	+0.270	+0.180	+0.110	+0.070	+0.043	+0.027	+0.018	+0.011	+0.008
To 18	0.000	0.000	0.000	0.000	0.000	0.000	0.000	0.000	0.000	0.000	0.000
Over 18	+0.840	+0.520	+0.330	+0.210	+0.130	+0.084	+0.052	+0.033	+0.021	+0.013	+0.009
To 24	0.000	0.000	0.000	0.000	0.000	0.000	0.000	0.000	0.000	0.000	0.000
Over 24	+0.840	+0.520	+0.330	+0.210	+0.130	+0.084	+0.052	+0.033	+0.021	+0.013	+0.009
To 30	0.000	0.000	0.000	0.000	0.000	0.000	0.000	0.000	0.000	0.000	0.000
Over 30	+1.000	+0.620	+0.390	+0.250	+0.160	+0.100	+0.062	+0.039	+0.025	+0.016	+0.011
To 40	0.000	0.000	0.000	0.000	0.000	0.000	0.000	0.000	0.000	0.000	0.000
Over 40	+1.000	+0.620	+0.390	+0.250	+0.160	+0.100	+0.062	+0.039	+0.025	+0.016	+0.011
To 50	0.000	0.000	0.000	0.000	0.000	0.000	0.000	0.000	0.000	0.000	0.000
Over 50	+1.200	+0.740	+0.460	+0.300	+0.190	+0.120	+0.074	+0.046	+0.030	+0.019	+0.013
To 65	0.000	0.000	0.000	0.000	0.000	0.000	0.000	0.000	0.000	0.000	0.000
Over 65	+1.200	+0.740	+0.460	+0.300	+0.190	+0.120	+0.074	+0.046	+0.030	+0.019	+0.013
To 80	0.000	0.000	0.000	0.000	0.000	0.000	0.000	0.000	0.000	0.000	0.000
Over 80	+1.400	+0.870	+0.540	+0.350	+0.220	+0.140	+0.087	+0.054	+0.035	+0.022	+0.015
To 100	0.000	0.000	0.000	0.000	0.000	0.000	0.000	0.000	0.000	0.000	0.000
Over 100	+1.400	+0.870	+0.540	+0.350	+0.220	+0.140	+0.087	+0.054	+0.035	+0.022	+0.015
To 120	0.000	0.000	0.000	0.000	0.000	0.000	0.000	0.000	0.000	0.000	0.000
Over 120	+1.600	+1.000	+0.630	+0.400	+0.250	+0.160	+0.100	+0.063	+0.040	+0.025	+0.018
To 140	0.000	0.000	0.000	0.000	0.000	0.000	0.000	0.000	0.000	0.000	0.000
Over 140	+1.600	+1.000	+0.630	+0.400	+0.250	+0.160	+0.100	+0.063	+0.040	+0.025	+0.018
To 160	0.000	0.000	0.000	0.000	0.000	0.000	0.000	0.000	0.000	0.000	0.000
Over 160	+1.600	+1.000	+0.630	+0.400	+0.250	+0.160	+0.100	+0.063	+0.040	+0.025	+0.018
To 180	0.000	0.000	0.000	0.000	0.000	0.000	0.000	0.000	0.000	0.000	0.000
Over 180	+1.850	+1.150	+0.720	+0.460	+0.290	+0.185	+0.115	+0.072	+0.046	+0.029	+0.020
To 200	0.000	0.000	0.000	0.000	0.000	0.000	0.000	0.000	0.000	0.000	0.000

## Tolerance zones for external LinearRace® shaft dimensions (h15 through h5) (Dimensions in mm)

Basic Size	h15	h14	h13	h12	h11	h10	h9	h8	h7	h6	h5
Over 6	0.000	0.000	0.000	0.000	0.000	0.000	0.000	0.000	0.000	0.000	0.000
To 10	-0.580	-0.360	-0.220	-0.150	-0.090	-0.058	-0.036	-0.022	-0.015	-0.009	-0.006
Over 10	0.000	0.000	0.000	0.000	0.000	0.000	0.000	0.000	0.000	0.000	0.000
To 14	-0.700	-0.430	-0.270	-0.180	-0.110	-0.070	-0.043	-0.027	-0.018	-0.011	-0.008
Over 14	0.000	0.000	0.000	0.000	0.000	0.000	0.000	0.000	0.000	0.000	0.000
To 18	-0.700	-0.430	-0.270	-0.180	-0.110	-0.070	-0.043	-0.027	-0.018	-0.011	-0.008
Over 18	0.000	0.000	0.000	0.000	0.000	0.000	0.000	0.000	0.000	0.000	0.000
To 24	-0.840	-0.520	-0.330	-0.210	-0.130	-0.084	-0.052	-0.033	-0.021	-0.013	-0.009
Over 24	0.000	0.000	0.000	0.000	0.000	0.000	0.000	0.000	0.000	0.000	0.000
To 30	-0.840	-0.520	-0.330	-0.210	-0.130	-0.084	-0.052	-0.033	-0.021	-0.013	-0.009
Over 30	0.000	0.000	0.000	0.000	0.000	0.000	0.000	0.000	0.000	0.000	0.000
To 40	-1.000	-0.620	-0.390	-0.250	-0.160	-0.100	-0.062	-0.039	-0.025	-0.016	-0.011
Over 40	0.000	0.000	0.000	0.000	0.000	0.000	0.000	0.000	0.000	0.000	0.000
To 50	-1.000	-0.620	-0.390	-0.250	-0.160	-0.100	-0.062	-0.039	-0.025	-0.016	-0.011
Over 50	0.000	0.000	0.000	0.000	0.000	0.000	0.000	0.000	0.000	0.000	0.000
To 65	-1.200	-0.740	-0.460	-0.300	-0.190	-0.120	-0.074	-0.046	-0.030	-0.019	-0.013
Over 65	0.000	0.000	0.000	0.000	0.000	0.000	0.000	0.000	0.000	0.000	0.000
To 80	-1.200	-0.740	-0.460	-0.300	-0.190	-0.120	-0.074	-0.046	-0.030	-0.019	-0.013
Over 80	0.000	0.000	0.000	0.000	0.000	0.000	0.000	0.000	0.000	0.000	0.000
To 100	-1.400	-0.870	-0.540	-0.350	-0.220	-0.140	-0.087	-0.054	-0.035	-0.022	-0.015
Over 100	0.000	0.000	0.000	0.000	0.000	0.000	0.000	0.000	0.000	0.000	0.000
To 120	-1.400	-0.870	-0.540	-0.350	-0.220	-0.140	-0.087	-0.054	-0.035	-0.022	-0.015
Over 120	0.000	0.000	0.000	0.000	0.000	0.000	0.000	0.000	0.000	0.000	0.000
To 140	-1.600	-1.000	-0.630	-0.400	-0.250	-0.160	-0.100	-0.063	-0.040	-0.025	-0.018
Over 140	0.000	0.000	0.000	0.000	0.000	0.000	0.000	0.000	0.000	0.000	0.000
To 160	-1.600	-1.000	-0.630	-0.400	-0.250	-0.160	-0.100	-0.063	-0.040	-0.025	-0.018
Over 160	0.000	0.000	0.000	0.000	0.000	0.000	0.000	0.000	0.000	0.000	0.000
To 180	-1.600	-1.000	-0.630	-0.400	-0.250	-0.160	-0.100	-0.063	-0.040	-0.025	-0.018
Over 180	0.000	0.000	0.000	0.000	0.000	0.000	0.000	0.000	0.000	0.000	0.000
To 200	-1.850	-1.150	-0.720	-0.460	-0.290	-0.185	-0.115	-0.072	-0.046	-0.029	-0.020



# Engineering Conversion Factors

QUANTITY	CONVENTIONAL		SI Unit	Conversion Factors
	Inch Unit	Metric Unit (MKS)		
LENGTH	Inch in.	Meter m	Metre m	1 in. = 25.4 mm
				1 mm = 0.03937 in.
				1 m = 3.2808 ft.
				1 ft. = 0.3048 m
				1 in. <sup>2</sup> = 6.4516 cm <sup>2</sup>
AREA	Square Inch in. <sup>2</sup>	Square Meter m <sup>2</sup>	Square Metre m <sup>2</sup>	1 cm <sup>2</sup> = 0.155 in. <sup>2</sup>
				1 m <sup>2</sup> = 10.764 ft <sup>2</sup>
				1 ft. <sup>2</sup> = 0.092903 m <sup>2</sup>
MASS	Pound lb <sub>m</sub>	Kilogram kg	Kilogram kg	1 lb <sub>m</sub> = 0.45359237 kg
				1 kg = 2.2046 lb
				1 lb <sub>f</sub> = 0.45359237 kg <sub>f</sub>
FORCE	Pound Force lb <sub>f</sub>	Kilogram Force kg <sub>f</sub>	Newton N	1 lb <sub>f</sub> = 4.44822 N
				1 kg <sub>f</sub> = 2.2046 lbf
				1 kg <sub>f</sub> = 9.80665 N
				1 N = 0.1019716 kg <sub>f</sub>
STRESS or PRESSURE	Pounds per square inch lb/in. <sup>2</sup>	Kilograms per square meter kg/m <sup>2</sup>	Pascal Pa	1 MPa = 10 <sup>6</sup> N/m <sup>2</sup> = N/mm <sup>2</sup>
				1 kPa = 10 <sup>3</sup> N/m <sup>2</sup>
				1 lb <sub>f</sub> /inch <sup>2</sup> = 0.070307 kg <sub>f</sub> /cm <sup>2</sup>
				1 lb <sub>f</sub> /inch <sup>2</sup> = 7.0307 × 10 <sup>-3</sup> kg <sub>f</sub> /mm <sup>2</sup>
				1 lb <sub>f</sub> /inch <sup>2</sup> = 6.8947 × 10 <sup>-3</sup> N/mm <sup>2</sup> (MPa)
				1 kg <sub>f</sub> /cm <sup>2</sup> = 14.2233 lb <sub>f</sub> /in. <sup>2</sup>
				1 kg <sub>f</sub> /cm <sup>2</sup> = 9.80665 × 10 <sup>-2</sup> N/mm <sup>2</sup> (MPa)
TORQUE or WORK	Inch Pounds lb <sub>f</sub> -in.	Kilogram Meters kg <sub>f</sub> -m	Newton- Metres Nm	1 lb <sub>f</sub> -in. = 1.1521 kg <sub>f</sub> -cm
				1 kg <sub>f</sub> -cm = 0.8679 lb <sub>f</sub> -in.
				1 lb <sub>f</sub> -in. = 0.1129848 Nm
				1 kg <sub>f</sub> -m = 9.80665 Nm
				1 kg <sub>f</sub> -cm = 9.80665 × 10 <sup>-2</sup> Nm
				1 Nm = 8.85 lb <sub>f</sub> -in.
POWER	Foot pound per minute lb <sub>f</sub> -ft./min.	Force per second kg <sub>f</sub> -m/s	Newton Metre per second Nm/s	1 kW = 1000 Nm/s
				1 kW = 60,000 Nm/s
				1 kW = 44,220 lb <sub>f</sub> -ft./min.
				1 kW = 1.341 hp
				1 hp = 75 kg <sub>f</sub> -m/s
				1 hp = 44,741 Nm/min.
				1 hp = 33,000 lb <sub>f</sub> -ft./min.
1 hp = 0.7457 kW				
VELOCITY	Feet per second ft./s	Meters per second m/s	Meters per second m/s	1 ft./sec. = 0.3048 m/s
				1 in./sec. = 2.54 cm/s
				1 ft./sec. = 0.00508 m/s
				1 mile/hr. = 0.44704 m/s
				1 km/hr. = 0.27777 m/s
ACCELERATION	Feet per second squared ft./s <sup>2</sup>	Meters per second squared m/s <sup>2</sup>	Metres per second squared m/s <sup>2</sup>	1 ft./s <sup>2</sup> = 0.3048 m/s <sup>2</sup>
				1 mile/hr = 1.609344 km/hr.

## Shafting Color Code Chart

Material	Class	Random Length	
Carbon Steel	S	Painted	
Carbon Steel	L	1/2 Black 1/2 Red	
Carbon Steel	N	Gray	
Carbon Steel	D	1/2 Gray 1/2 Green	
Carbon Steel	Metric H6	Orange	
Carbon Steel	Metric H4	1/2 Blue 1/2 Orange	
Carbon Steel	Metric G6	1/2 Green 1/2 Orange	
Carbon Steel Chrome	All	1/2 Blue	
440C Stainless Steel	S	No Color	
440C Stainless Steel	L	1/2 Orange	
316 Stainless Steel	L	1/2 Cyan	
440C Stainless Steel	Metric	1/2 Yellow	
52100 Tubular	S	No Color	
52100 Tubular	L	1/2 Black 1/2 Red	
Carbon Steel Deep Case	L	1/2 Beige 1/2 Pink	
Carbon Steel Deep Case	N	1/2 Gray 1/2 Pink	
Carbon Steel Deep Case	Metric H6	Pink	

Contact us or any of our 2000+ global distribution partners by scanning the code below  
or visiting [www.thomsonlinear.com/contact](http://www.thomsonlinear.com/contact)



**RegalRexnord™**

[www.regalrexnord.com](http://www.regalrexnord.com)

[www.thomsonlinear.com](http://www.thomsonlinear.com)

RoundRail\_LinearGuides\_Components\_CTUK-0002-10 | 20260218KB | MCC-12411-TL-EN-A4 02/26  
Specifications are subject to change without notice. It is the responsibility of the product user to  
determine the suitability of this product for a specific application. All trademarks property of their  
respective owners. ©2026 Thomson Industries, Inc. | 2400 Curtiss Street, Downers Grove, IL 60515 USA

**THOMSON®**